



Cisco Interface Cards Hardware Installation Guide

For the Cisco 1600 Series, Cisco 1700 Series, Cisco 1800 Series, Cisco 2600 Series, Cisco 2800 Series, Cisco 3600 Series, Cisco 3700 Series, and Cisco 3800 Series Routers, the Cisco ICS 7750, and the Cisco MWR 1941-DC Mobile Wireless Edge Router

Corporate Headquarters

Cisco Systems, Inc.
170 West Tasman Drive
San Jose, CA 95134-1706
USA
<http://www.cisco.com>
Tel: 408 526-4000
800 553-NETS (6387)
Fax: 408 526-4100



THE SPECIFICATIONS AND INFORMATION REGARDING THE PRODUCTS IN THIS MANUAL ARE SUBJECT TO CHANGE WITHOUT NOTICE. ALL STATEMENTS, INFORMATION, AND RECOMMENDATIONS IN THIS MANUAL ARE BELIEVED TO BE ACCURATE BUT ARE PRESENTED WITHOUT WARRANTY OF ANY KIND, EXPRESS OR IMPLIED. USERS MUST TAKE FULL RESPONSIBILITY FOR THEIR APPLICATION OF ANY PRODUCTS.

THE SOFTWARE LICENSE AND LIMITED WARRANTY FOR THE ACCOMPANYING PRODUCT ARE SET FORTH IN THE INFORMATION PACKET THAT SHIPPED WITH THE PRODUCT AND ARE INCORPORATED HEREIN BY THIS REFERENCE. IF YOU ARE UNABLE TO LOCATE THE SOFTWARE LICENSE OR LIMITED WARRANTY, CONTACT YOUR CISCO REPRESENTATIVE FOR A COPY.

The following information is for FCC compliance of Class A devices: This equipment has been tested and found to comply with the limits for a Class A digital device, pursuant to part 15 of the FCC rules. These limits are designed to provide reasonable protection against harmful interference when the equipment is operated in a commercial environment. This equipment generates, uses, and can radiate radio-frequency energy and, if not installed and used in accordance with the instruction manual, may cause harmful interference to radio communications. Operation of this equipment in a residential area is likely to cause harmful interference, in which case users will be required to correct the interference at their own expense.

The following information is for FCC compliance of Class B devices: The equipment described in this manual generates and may radiate radio-frequency energy. If it is not installed in accordance with Cisco's installation instructions, it may cause interference with radio and television reception. This equipment has been tested and found to comply with the limits for a Class B digital device in accordance with the specifications in part 15 of the FCC rules. These specifications are designed to provide reasonable protection against such interference in a residential installation. However, there is no guarantee that interference will not occur in a particular installation.

Modifying the equipment without Cisco's written authorization may result in the equipment no longer complying with FCC requirements for Class A or Class B digital devices. In that event, your right to use the equipment may be limited by FCC regulations, and you may be required to correct any interference to radio or television communications at your own expense.

You can determine whether your equipment is causing interference by turning it off. If the interference stops, it was probably caused by the Cisco equipment or one of its peripheral devices. If the equipment causes interference to radio or television reception, try to correct the interference by using one or more of the following measures:

- Turn the television or radio antenna until the interference stops.
- Move the equipment to one side or the other of the television or radio.
- Move the equipment farther away from the television or radio.
- Plug the equipment into an outlet that is on a different circuit from the television or radio. (That is, make certain the equipment and the television or radio are on circuits controlled by different circuit breakers or fuses.)

Modifications to this product not authorized by Cisco Systems, Inc. could void the FCC approval and negate your authority to operate the product.

The Cisco implementation of TCP header compression is an adaptation of a program developed by the University of California, Berkeley (UCB) as part of UCB's public domain version of the UNIX operating system. All rights reserved. Copyright © 1981, Regents of the University of California.

NOTWITHSTANDING ANY OTHER WARRANTY HEREIN, ALL DOCUMENT FILES AND SOFTWARE OF THESE SUPPLIERS ARE PROVIDED "AS IS" WITH ALL FAULTS. CISCO AND THE ABOVE-NAMED SUPPLIERS DISCLAIM ALL WARRANTIES, EXPRESSED OR IMPLIED, INCLUDING, WITHOUT LIMITATION, THOSE OF MERCHANTABILITY, FITNESS FOR A PARTICULAR PURPOSE AND NONINFRINGEMENT OR ARISING FROM A COURSE OF DEALING, USAGE, OR TRADE PRACTICE.

IN NO EVENT SHALL CISCO OR ITS SUPPLIERS BE LIABLE FOR ANY INDIRECT, SPECIAL, CONSEQUENTIAL, OR INCIDENTAL DAMAGES, INCLUDING, WITHOUT LIMITATION, LOST PROFITS OR LOSS OR DAMAGE TO DATA ARISING OUT OF THE USE OR INABILITY TO USE THIS MANUAL, EVEN IF CISCO OR ITS SUPPLIERS HAVE BEEN ADVISED OF THE POSSIBILITY OF SUCH DAMAGES.

CCVP, the Cisco logo, and Welcome to the Human Network are trademarks of Cisco Systems, Inc.; Changing the Way We Work, Live, Play, and Learn is a service mark of Cisco Systems, Inc.; and Access Registrar, Aironet, Catalyst, CCDA, CCDP, CCIE, CCIP, CCNA, CCNP, CCSP, Cisco, the Cisco Certified Internetwork Expert logo, Cisco IOS, Cisco Press, Cisco Systems, Cisco Systems Capital, the Cisco Systems logo, Cisco Unity, Enterprise/Solver, EtherChannel, EtherFast, EtherSwitch, Fast Step, Follow Me Browsing, FormShare, GigaDrive, HomeLink, Internet Quotient, IOS, iPhone, IP/TV, iQ Expertise, the iQ logo, iQ Net Readiness Scorecard, iQuick Study, LightStream, Linksys, MeetingPlace, MGX, Networkers, Networking Academy, Network Registrar, PIX, ProConnect, ScriptShare, SMARTnet, StackWise, The Fastest Way to Increase Your Internet Quotient, and TransPath are registered trademarks of Cisco Systems, Inc. and/or its affiliates in the United States and certain other countries.

All other trademarks mentioned in this document or Website are the property of their respective owners. The use of the word partner does not imply a partnership relationship between Cisco and any other company. (0711R)



Cisco Interface Cards for Cisco Access Routers

Revised: 6/7/07, OL-12796-01

Overview

This document provides an overview of Cisco interface cards used in Cisco access routers, and contains the following sections:

- Introduction to Cisco Interface Cards, page 1
- Cisco Access Routers and Cisco Interface Cards, page 2
- Cisco IOS Software Releases and Cisco Interface Cards, page 10
- Cisco Network Modules Supporting Cisco Interface Cards, page 11
- Cabling for Cisco Interface Cards, page 12
- Platform Support for Cisco Interface Cards, page 15
- Related Documents, page 27
- Where to Go Next, page 30
- Obtaining Documentation, Obtaining Support, and Security Guidelines, page 30

Introduction to Cisco Interface Cards

Cisco interface cards are classified according to the technologies they support. For example, WAN interface cards (WICs) support WAN technologies, such as Gigabit Ethernet, and voice interface cards (VICs) support voice technologies. Voice/WAN interface cards (VWICs) can support voice, data, and voice and data applications, depending on the capabilities of the router in which the VWIC is installed. High-speed WAN interface cards (HWIC) provide expanded LAN and WAN capabilities, such as Gigabit Ethernet and Ethernet switching.



Note

HWICs are supported on Cisco 1800 series (modular), Cisco 2800 series, and Cisco 3800 series routers.

Cisco interface cards are available in the following two form factors to provide greater modularity and functionality for users:

- Single-wide interface cards (see Figure 1)
- Double-wide interface cards (see Figure 2)

Single-wide interface cards can be installed in interface card slots on supported Cisco access routers, in 1- or 2-slot network modules to be installed in network module slots on supported Cisco access routers, and in interface card slots on Cisco 1800 (modular) series, Cisco 2800 series, and Cisco 3800 series routers. See Figure 1 for a sample single-wide interface card.

Figure 1 Sample Single-Wide Interface Card

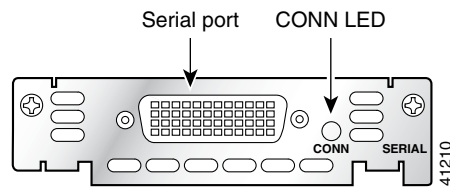

Double-wide interface cards can only be installed in interface card slots on Cisco 2800 series and Cisco 3800 series routers. See Figure 2 for a sample double-wide interface card.

Figure 2 Sample Double-Wide Interface Card

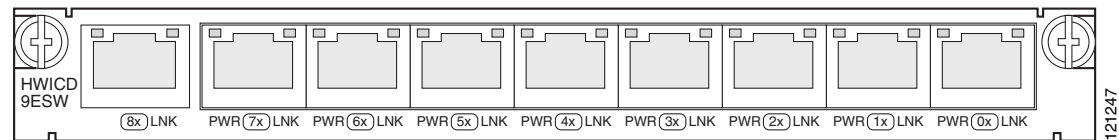

Cisco Access Routers and Cisco Interface Cards

The Cisco interface cards described in this book are supported on the following Cisco routers:

- The Cisco 1600 series, including the Cisco 1601, Cisco 1602, Cisco 1603, Cisco 1604, Cisco 1605-R routers (see Figure 3)
- The Cisco 1700 series (modular), including the Cisco 1720, Cisco 1721, Cisco 1750, Cisco 1751, and Cisco 1760 routers (see Figure 4, Figure 5, and Figure 6)
- The Cisco 1800 series (modular), including the Cisco 1841 routers (see Figure 7)
- The Cisco 2600 series, including the Cisco 2610, Cisco 2610XM, Cisco 2611, Cisco 2611XM, Cisco 2612, Cisco 2613, Cisco 2620, Cisco 2620XM, Cisco 2621, Cisco 2621XM, Cisco 2650, Cisco 2650XM, Cisco 2651, Cisco 2651XM, and Cisco 2691 routers (see Figure 8)



Note References to the Cisco 2600XM routers apply to the following routers: Cisco 2610XM, Cisco 2611XM, Cisco 2620XM, Cisco 2621XM, Cisco 2650XM, and Cisco 2651XM.

- The Cisco 2800 series, including the Cisco 2801, Cisco 2811, Cisco 2821, and Cisco 2851 routers (see Figure 9 and Figure 10)
- The Cisco 3600 series, including the Cisco 3620, Cisco 3631, Cisco 3640, Cisco 3640A, Cisco 3661, and Cisco 3662 routers (figure not shown)



Note Cisco 3600 series routers do not have built-in interface card slots. However, interface cards are supported when installed in a 1- or 2-slot network module.

- The Cisco 3700 series, including the Cisco 3725 and Cisco 3745 routers (see Figure 11 and Figure 12)
- The Cisco 3800 series, including the Cisco 3825 and Cisco 3845 routers (see Figure 13)
- Cisco MWR 1941-DC routers (see Figure 14)
- Cisco ICS 7750 routers

For information on these Cisco routers, see the hardware documentation described in the “Related Documents” section on page 27.



Note

Certain Cisco interface cards are also supported on the Cisco ICS 7750. See Table 4 for more information.

Interface Card Slot Locations and Numbering on Cisco Access Routers

See Figure 3 through Figure 14 for interface card slot locations on sample Cisco access routers. Refer to the hardware documentation for your router for detailed information on slot and interface numbering.

Figure 3 *Interface Card Slot Locations on Cisco 1600 Series Routers (Cisco 1601 Router Shown)*

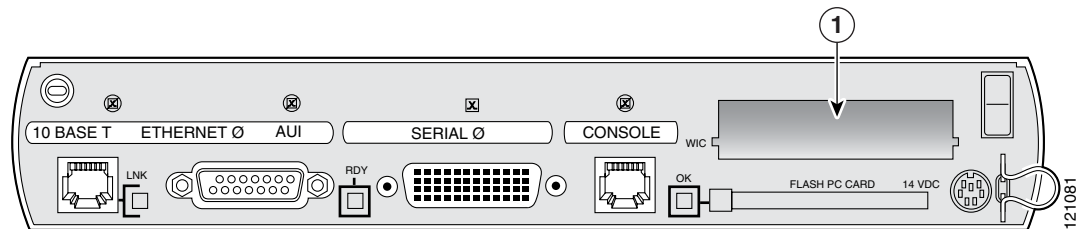

1	Interface card slot
----------	---------------------

Figure 4 *Interface Card Slot Locations on Cisco 1721 Routers*

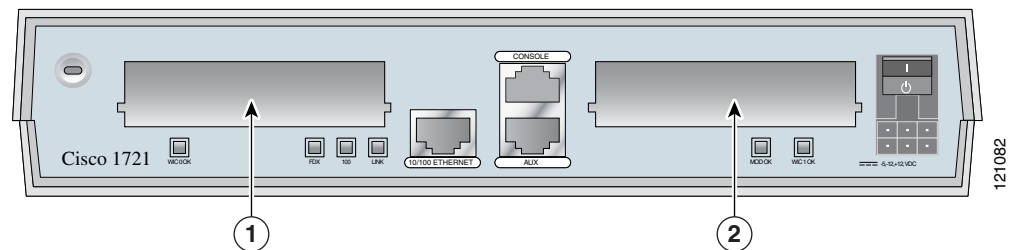

1	WIC slot 0
----------	------------

2	WIC slot 1
----------	------------

Figure 5 Interface Card Slot Locations on Cisco 1750 and Cisco 1751 Routers (Cisco 1751 Shown)

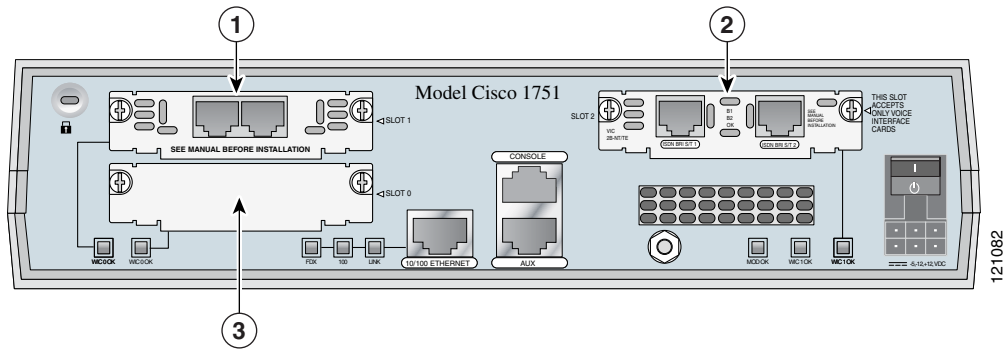

1	Interface card slot 1	2	VIC slot 2
3	Interface card slot 0		

Figure 6 Interface Card Slot Locations on Cisco 1760 Routers

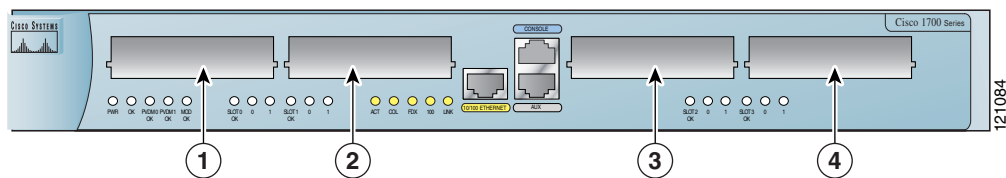

1	Interface card slot 0	2	Interface card slot 1
3	VIC slot 2	4	VIC slot 3

Figure 7 Interface Card Slot Locations on Cisco 1800 Series (Modular) Series Routers (Cisco 1841 Router Shown)

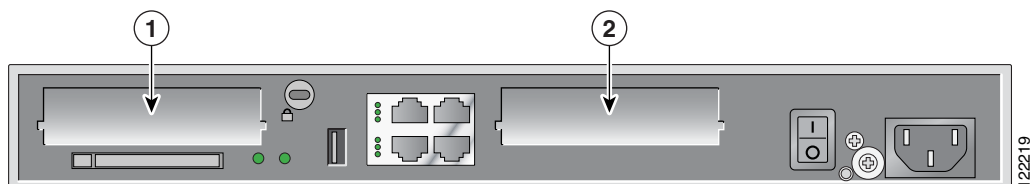

1	WIC, VWIC—data only, or HWIC slot 1	2	WIC, VWIC—data only, or HWIC slot 0
----------	-------------------------------------	----------	-------------------------------------

Figure 8 Interface Card Slot Locations on Cisco 2600 Series Routers (Cisco 2612 Router Shown)

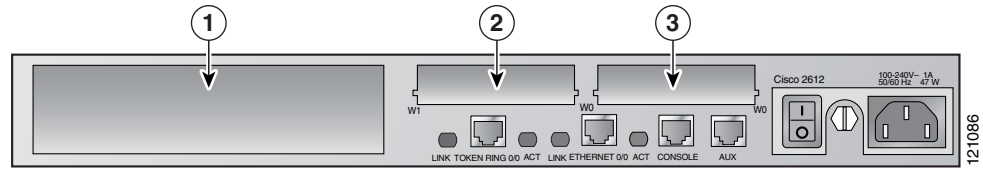

1	Network module slot	2	WIC slot 1
3	WIC slot 0		

Figure 9 Interface Card Slot Locations on Cisco 2801 Routers

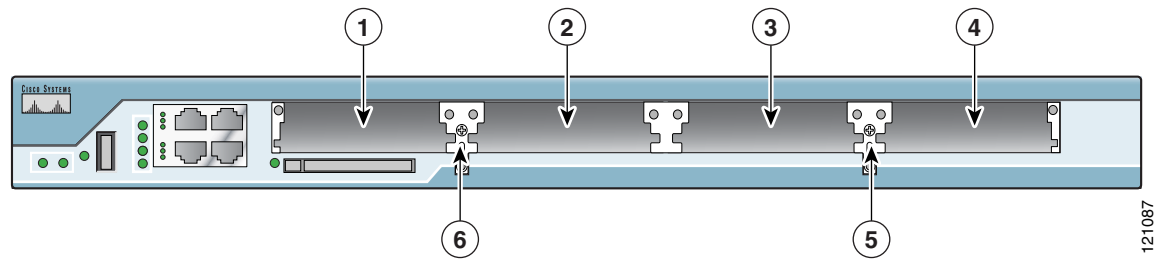

1	WIC/VIC/VWIC/HWIC slot 3	2	WIC/VIC/VWIC slot 2
3	WIC/VIC/VWIC/HWIC slot 1	4	VIC/VWIC (voice only) slot 0
5	Interface card slot divider	6	Interface card slot divider

Note

To install double-wide interface cards in Cisco 2801 routers, remove the slot divider. When the slot dividers are removed, slot 0 and slot 1 become slot 1, and slot 2 and slot 3 become slot 3.

Figure 10 Interface Card Slot Locations on Cisco 2800 Series Routers (Cisco 2851 Router Shown)

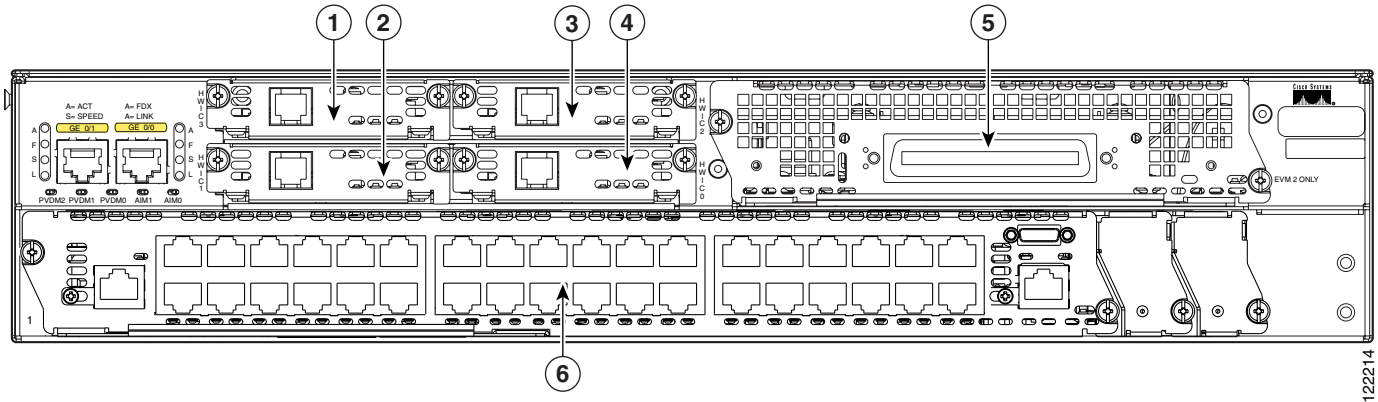

1	HWIC slot 3	2	HWIC slot 1
3	HWIC slot 2	4	HWIC slot 0
5	Extension voice module (EVM) slot	6	Network module enhanced (NME) slot

**Note**

To install double-wide interface cards in Cisco 2811, Cisco 2821, and Cisco 2851 routers, remove the slot divider. When the slot dividers are removed, slot 0 and slot 1 become slot 1, and slot 2 and slot 3 become slot 3.

Figure 11 Interface Card Slot Locations on Cisco 3725 Routers

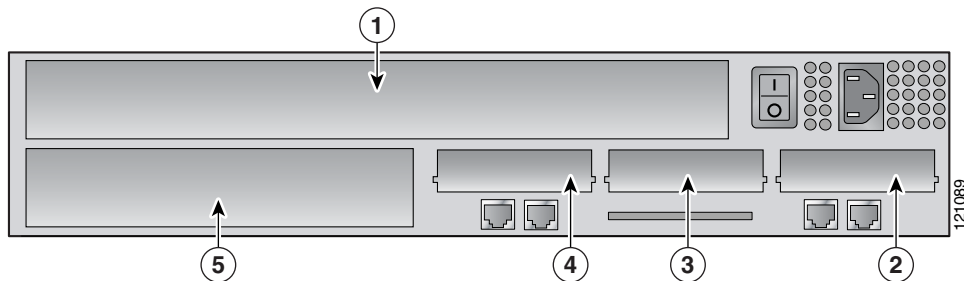

1	Network module slot (double-wide)	2	Interface card slot 0
3	Interface card slot 1	4	Interface card slot 2
5	Network module slot (single-wide)		

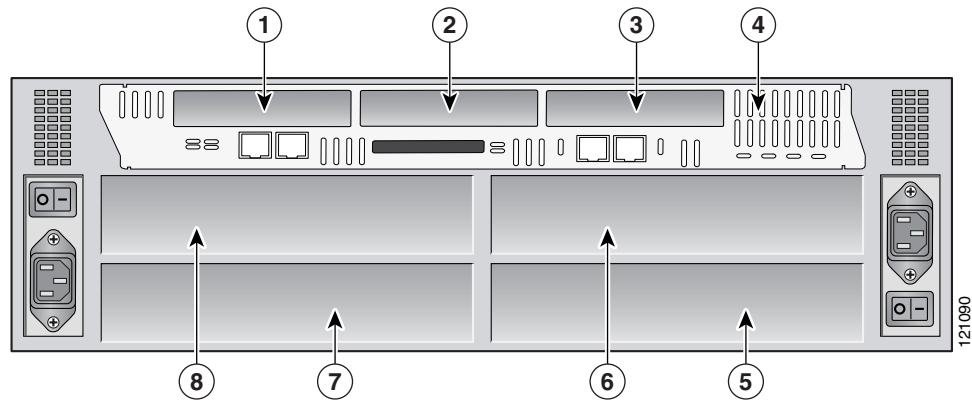
Figure 12 Interface Card Slot Locations on Cisco 3745 Routers

1	Interface card slot 2	2	Interface card slot 1
3	Interface card slot 0	4	Interface card slot
5	Network module slot (single-wide)	6	Network module slot (single-wide)
7	Network module slot (single-wide)	8	Network module slot (single-wide)

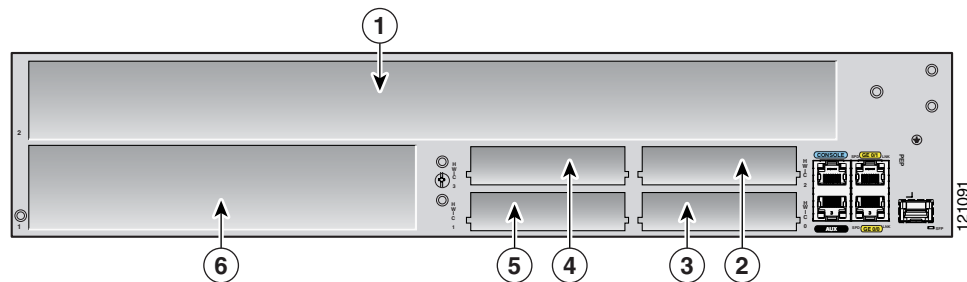
Figure 13 Interface Card Slot Locations on Cisco 3800 Series Routers (Cisco 3825 Router Shown)

1	Network module slot 2 (extended double-wide)	2	HWIC slot 2
3	HWIC slot 0	4	HWIC slot 3
5	HWIC slot 1	6	Network module slot 1 (extended single-wide)

**Note**

To install double-wide interface cards in Cisco 3800 series routers, remove the slot divider. When the slot dividers are removed, slot 0 and slot 1 become slot 1, and slot 2 and slot 3 become slot 3.

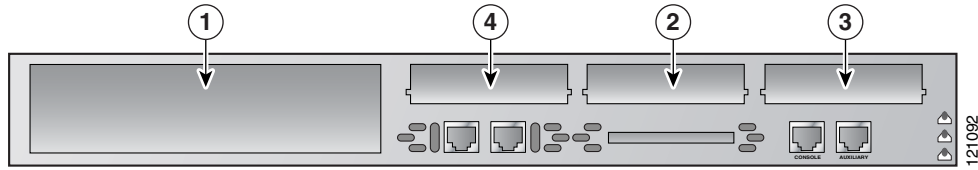
Figure 14 Interface Card Slot Locations on Cisco MWR 1941-DC Routers

1	Network module slot	2	Interface card slot 1
3	Interface card slot 0	4	Interface card slot 2

Platform Slot Numbering and Limitations for Cisco Interface Cards

Certain platforms have restrictions on the number of total interface cards of a certain type that can be installed, and some slots do not support certain interface cards.

See Table 1 for information about the interface card slots available on Cisco access routers.

Table 1 Interface Card Slots Available on Cisco Access Routers

Cisco Router	Number of Slots	Slot Type	Slot Numbering	Installation Notes and Limitations
Cisco 1600 series	1	Single-wide	–	Routers do not support HWICs.
Cisco 1720 routers	2	Single-wide	Slot 0, slot 1	Routers do not support HWICs.
Cisco 1750 and Cisco 1751 routers	3	Single-wide	Slot 0 through slot 2	Slot 2 supports VICs only. Routers do not support HWICs.
Cisco 1760 routers	4	Single-wide	Slot 0 through slot 3	Slot 2 and slot 3 support VICs only. Routers do not support HWICs.
Cisco 1800 series	2	Single-wide	Slot 0, slot 1	Does not support VICs. Does not support double-wide HWICs. Supports VWICs for data applications only.
Cisco 2600 series	2	Single-wide	Slot 0, slot 1	Does not support VICs in chassis slots. Routers do not support HWICs.

Table 1 **Interface Card Slots Available on Cisco Access Routers (continued)**

Cisco Router	Number of Slots	Slot Type	Slot Numbering	Installation Notes and Limitations
Cisco 2801 routers	4	Single-wide	Slot 0 through slot 3	Slot 0 supports only VICs and VWICs in voice mode only. Slot 1 and slot 3 support HWICs. Slot 0 and slot 2 do not support HWICs.
	2	Double-wide	Slot 1, slot 3	Removing the slot divider changes slot numbering as follows: <ul style="list-style-type: none"> Slot 0 and slot 1 become slot 1 Slot 2 and slot 3 become slot 3 Tip To install double-wide interface cards, remove the slot divider (see the “Installing Double-Wide Interface Cards” section in <i>Installing Cisco Interface Cards in Cisco Access Routers</i>).
Cisco 2811, Cisco 2821, and Cisco 2851 routers	4	Single-wide	Slot 0 through slot 3	–
	2	Double-wide	Slot 1, slot 3	Removing the slot divider changes slot numbering as follows: <ul style="list-style-type: none"> Slot 0 and slot 1 become slot 1 Slot 2 and slot 3 become slot 3 Tip To install double-wide interface cards, remove the slot divider (see the “Installing Double-Wide Interface Cards” section in <i>Installing Cisco Interface Cards in Cisco Access Routers</i>).
Cisco 3600 series	2, 4, or 6	Single-wide	Slot 0 through slot 6	To install an interface card in a Cisco 3600 series router, use a 1- or 2-slot network module (see the “Cisco Network Modules Supporting Cisco Interface Cards” section on page 11). Cisco 3600 series routers do not have interface card slots on the chassis. Routers do not support HWICs.
Cisco 3660	2, 4, or 6	Single-wide or double-wide	Slot 0 through slot 6	To install an interface card in a Cisco 3600 series router, use a 1- or 2-slot network module (see the “Cisco Network Modules Supporting Cisco Interface Cards” section on page 11). Cisco 3600 series routers do not have interface card slots on the chassis. Routers do not support HWICs.
Cisco 3700 series	3	Single-wide	Slot 0 through slot 2	Does not support VICs in chassis slots. Routers do not support HWICs.

Table 1 Interface Card Slots Available on Cisco Access Routers (continued)

Cisco Router	Number of Slots	Slot Type	Slot Numbering	Installation Notes and Limitations
Cisco 3800 series	4	Single-wide	Slot 0 through slot 3	–
	2	Double-wide	Slot 1, slot 3	<p>Removing the slot divider changes slot numbering as follows:</p> <ul style="list-style-type: none"> Slot 0 and slot 1 become slot 1 Slot 2 and slot 3 become slot 3 <p>Tip To install double-wide interface cards, remove the slot divider (see the “Installing Double-Wide Interface Cards” section in <i>Installing Cisco Interface Cards in Cisco Access Routers</i>).</p>
Cisco ICS 7750	–	–	–	<p>Routers do not support HWICs.</p> <p>To install interface cards in the Cisco ICS 7750, use a multiroute processor (MRP) or analog station interface 81 (ASI 81) card.</p> <p>Tip Refer to the “Processor Cards Feature Summary” chapter in the <i>Cisco ICS 7750 System Description</i> document for more information about these cards.</p>
Cisco MWR 1941-DC routers	1	Single-wide	Slot 1 through slot 3	Routers do not support HWICs.

Cisco IOS Software Releases and Cisco Interface Cards

Cisco interface cards are often supported on multiple Cisco IOS releases. Cisco IOS release information is documented in the product data sheet and in Feature Navigator II.

To determine which Cisco IOS releases support your particular router and combination of cards and modules, go to the Software Advisor at <http://tools.cisco.com/Support/Fusion/>.

You must have an account on Cisco.com. If you do not have an account or have forgotten your username or password, click **Cancel** at the login dialog box and follow the instructions that appear.

Cisco Network Modules Supporting Cisco Interface Cards

Some Cisco network modules have interface card slots to allow installation of Cisco interface cards. These network modules have either one or two interface card slots, supporting either voice or data interface cards. See Figure 15 and Figure 16 for sample 1-slot and 2-slot network modules.

Note

Some combination voice/data interface cards are supported on 1- or 2-slot network modules. However, interface card functionality is limited to either voice or data applications. See Table 1 for more information.

Figure 15 Sample 1-Slot Network Module

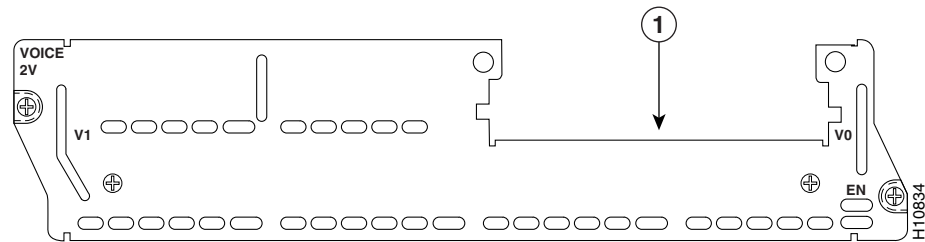

1	Interface card slot 0
----------	-----------------------

Figure 16 Sample 2-Slot Network Module

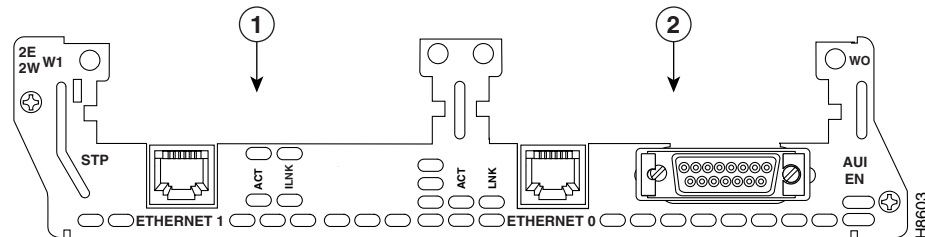

1	Interface card slot 1
----------	-----------------------

2	Interface card slot 0
----------	-----------------------

For information on installing interface cards onto network modules, see *Installing Cisco Interface Cards in Cisco Access Routers*.

For more information about Cisco network modules, see the *Cisco Network Modules Hardware Installation Guide*.

Cabling for Cisco Interface Cards

The cables required to connect the interface card to the network differ according to interface and connector type. See Table 2 for more information.

**Note**

Cabling for 1- or 2-slot network modules is determined by the installed interface cards.

**Note**

For network-end connectors and pinout specifications of the cables connecting the voice cards, refer to the *Cisco Modular Access Router Specifications*. Look under the type of interface card.

Table 2 Cabling for Cisco Interface Cards

Technology			
Connection Type	Connector Type, Cable Color	Cable	Use with
Analog Dialup			
300 bps to 33.6 kbps analog dialup	RJ-11, pink	RJ-11 straight-through	WIC-1AM WIC-2AM WIC-1AM-V2 WIC-2AM-V2
Cable Modem			
Cable	F	CATV coaxial	HWIC-CABLE-D-2 HWIC-CABLE-E/J-2
DSL			
ADSL	RJ-11C/CA11A, lavender	RJ-11 straight-through	WIC-1ADSL WIC-1ADSL-DG WIC-1ADSL-I-DG HWIC-1ADSL HWIC-1ADSLI
SHDSL	RJ-11C/CA11A, lavender	RJ-11 straight-through for 2-wire RJ-14 straight-through for 4-wire	WIC-1SHDSL WIC-1SHDSL-V2 WIC-1SHDSL-V3
	RJ-11	RJ-11 straight-through	HWIC-2SHDSL
	RJ-45	RJ-45 straight-through	HWIC-4SHDSL
Ethernet			
Fast Ethernet, copper	RJ-45	100BASE-T Category 5 or above UTP	WIC-4ESW HWIC-4ESW HWIC-4ESW-POE HWIC-D-9ESW HWIC-D-9ESW-POE
Fast Ethernet, copper	RJ-45	<ul style="list-style-type: none"> For 10BASE-T operation, use Category 3, 4, or 5 UTP cable. For 100BASE-TX operation, use Category 5 UTP cable. 	HWIC-1FE HWIC-2FE

Table 2 **Cabling for Cisco Interface Cards**

Technology			
Connection Type	Connector Type, Cable Color	Cable	Use with
Gigabit Ethernet, copper	RJ-45	1000BASE-T Category 5 or above UTP	HWIC-1GE-SFP (through SFP)
Gigabit Ethernet, optical Note A single fiber link should not mix 62.5- and 50-micron cable.	LC, color according to optical wavelength	Optical fiber as specified on applicable data sheet	
ISDN Connections			
BRI S/T (external NT1)	RJ-48C	RJ-48C straight-through	WIC36-1B-S/T WIC-1B-S/T WIC-1B-S/T-V3 WIC-1B-S/T-LL
BRI S/T (external NT1)	RJ-45	RJ-45 Straight-through	HWIC-ADSL-B/ST HWIC-ADSLI-B/ST
BRI U (built-in NT1)	RJ-49C/CA-A11, red	RJ-11; RJ-21 if using NM-HDA, straight-through	WIC36-1B-U WIC-1B-U WIC-1B-U-V2
56/64 kbps DSU/CSU	8-pin modular, blue	RJ-48S straight-through	WIC-1DSU-56K4
T1/fractional T1 DSU/CSU	RJ-48C	RJ-48C straight-through	WIC-1DSU-T1 WIC-1DSU-T1-V2
Serial Connections			
Synchronous serial	60-pin D, blue	Serial transition cable (EIA/TIA-232, EIA/TIA-449, EIA/TIA-530 DTE, V.35, X.21, NRZ/NRZI)	WIC-1T
Serial	26-pin Cisco Smart serial	Cisco Smart serial interface cable (see Table 3)	HWIC-4A/S HWIC-4T WIC-2A/S WIC-2T
	68-pin	Cisco 4-port RS-232 DCE or DTE cable assembly (two cable assemblies are required for each HWIC-8A/S-RS232)	HWIC-8A/S-RS232
Cisco 8-port RS-232 DTE cable assembly (two cable assemblies are required for each HWIC-16A)		HWIC-8A HWIC-16A	

Table 2 Cabling for Cisco Interface Cards

Technology			
Connection Type	Connector Type, Cable Color	Cable	Use with
Voice Connections			
Digital voice, T1/E1	RJ-48C/CA81A, tan	RJ-48C straight-through	VIC-2BRI-NT/TE VIC2-2BRI-NT/TE VIC-2BRI-ST/TE VIC2-2BRI-ST/TE
Digital voice/data, T1/E1			VWIC-1MFT-E1 VWIC-1MFT-G703 VWIC-1MFT-T1 VWIC-2MFT-E1 VWIC-2MFT-E1-DI VWIC-2MFT-G703 VWIC-2MFT-T1 VWIC-2MFT-T1-DI VWIC2-1MFT-G703 VWIC2-1MFT-T1/E1 VWIC2-2MFT-G703 VWIC2-2MFT-T1/E1
Analog voice, FXS	RJ-11, gray	RJ-11 straight-through	VIC-2FXS VIC2-2FXS VIC-4FXS/DID
Analog voice, FXO	RJ-11, pink		VIC-2FXO VIC-2FXO-M1 VIC-2FXO-M2 VIC-2FXO-M3 VIC2-2FXO VIC2-4FXO
Analog voice, CAMA			VIC-2CAMA
Analog voice, DID	RJ-11		VIC-2DID
Analog voice, E&M	RJ-45, brown	RJ-45 straight-through	VIC-2E/M VIC2-2E/M

Table 3 Cisco 12-in-1 Smart Serial Interface Cable Part Numbers

Interface	DCE/DTE	Cisco Cable Part Number
EIA/TIA-232	Female DCE	CAB-SS-232FC
	Male DTE	CAB-SS-232MT
EIA/TIA-449	Female DCE	CAB-SS-449FC
	Male DTE	CAB-SS-449MT
EIA-530	Male DTE	CAB-SS-530MT
EIA-530A	Male DTE	CAB-SS-530AMT

Table 3 Cisco 12-in-1 Smart Serial Interface Cable Part Numbers

Interface	DCE/DTE	Cisco Cable Part Number
V.35	Female DCE	CAB-SS-V35FC
	Female DTE	CAB-SS-V35FT
	Male DCE	CAB-SS-V35MC
	Male DTE	CAB-SS-V35MT
X.21	Female DCE	CAB-SS-X21FC
	Male DTE	CAB-SS-X21MT

Platform Support for Cisco Interface Cards

Table 4 lists the platforms supported by each interface card. The interface cards are grouped by technology area:

- Analog Modem WAN Interface Cards
- Cable Modem High-Speed WAN Interface Cards
- DSL WAN Interface Cards
- Ethernet Switch WAN Interface Cards
- ISDN BRI WAN Interface Cards
- Serial WAN Interface Cards
- T1, E1, and G.703 Multiflex Trunk Voice and WAN Interface Cards
- Voice Interface Cards
- Wireless Interface Cards

Table 4 Platform Support for Cisco Interface Cards

Product Description	Cisco Product ID	Supported on Cisco Routers	See Document
Analog Modem WAN Interface Cards			
1-port analog modem WIC	WIC-1AM	Cisco 1721 Cisco 1751 Cisco 1760 Cisco 1800 series (modular) Cisco 2600 series Cisco 2800 series Cisco 3600 series Cisco 3700 series Cisco 3800 series	<i>Analog Modem WAN Interface Cards</i>
2-port analog modem WIC	WIC-2AM	Cisco 1721 Cisco 1751 Cisco 1760 Cisco 1800 series (modular) Cisco 2600 series Cisco 2800 series Cisco 3600 series Cisco 3700 series Cisco 3800 series	<i>Analog Modem WAN Interface Cards</i>

Table 4 Platform Support for Cisco Interface Cards (continued)

Product Description	Cisco Product ID	Supported on Cisco Routers	See Document
1-port analog modem WIC, version 2	WIC-1AM-V2	Cisco 1800 series (modular) Cisco 2600 series Cisco 2800 series Cisco 3700 series Cisco 3800 series	<i>Analog Modem WAN Interface Cards</i>
2-port analog modem WIC, version 2	WIC-2AM-V2	Cisco 1800 series (modular) Cisco 2600 series Cisco 2800 series Cisco 3700 series Cisco 3800 series	<i>Analog Modem WAN Interface Cards</i>
Cable Modem High-Speed WAN Interface Cards			
Cable modem HWIC, United States version	HWIC-CABLE-D-2	Cisco 1800 series (modular) Cisco 2691 Cisco 2800 series Cisco 3700 series Cisco 3800 series	<i>Cisco Cable Modem High-Speed WAN Interface Cards</i>
Cable modem HWIC, Europe and Japan version	HWIC-CABLE-E/J-2	Cisco 1800 series (modular) Cisco 2691 Cisco 2800 series Cisco 3700 series Cisco 3800 series	<i>Cisco Cable Modem High-Speed WAN Interface Cards</i>
Channel Service Unit/Data Service Unit (CSU/DSU) WAN Interface Cards			
1-port T1/fractional T1 DSU/CSU WIC	WIC-1DSU-T1	Cisco 1600 series Cisco 1721 Cisco 1751 Cisco 1760 Cisco 2600 series Cisco 3600 series Cisco 3700 series Cisco ICS 7750	<i>DSU/CSU WAN Interface Cards</i>
1-port T1/fractional T1 DSU/CSU WIC, version 2	WIC-1DSU-T1-V2	Cisco 1721 Cisco 1751 Cisco 1760 Cisco 1800 series (modular) Cisco 2600 series ¹ Cisco 2800 series Cisco 3631 routers Cisco 3700 series Cisco 3800 series Cisco ICS 7750	<i>DSU/CSU WAN Interface Cards</i>

Table 4 Platform Support for Cisco Interface Cards (continued)

Product Description	Cisco Product ID	Supported on Cisco Routers	See Document
1-port 4-wire 56/64 kbps CSU/DSU WIC	WIC-1DSU-56K4	Cisco 1600 series Cisco 1721 Cisco 1751 Cisco 1760 Cisco 1800 series (modular) Cisco 2600 series Cisco 2800 series Cisco 3600 series Cisco 3700 series Cisco 3800 series	<i>DSU/CSU WAN Interface Cards</i>
DSL WAN Interface Cards			
1-port ADSL-over-POTS WIC	WIC-1ADSL	Cisco 1721 Cisco 1751 Cisco 1760 Cisco 1800 series (modular) Cisco 2600 series Cisco 2800 series Cisco 3600 series Cisco 3700 series Cisco 3800 series	<i>DSL Interface Cards</i>
1-port ADSL-over-POTS with dying gasp WIC	WIC-1ADSL-DG	Cisco 1721 Cisco 1751 Cisco 1760 Cisco 1800 series (modular) Cisco 2600 series Cisco 2800 series Cisco 3700 series Cisco 3800 series	<i>DSL Interface Cards</i>
1-port ADSL-over-ISDN with dying gasp WIC	WIC-1ADSL-I-DG	Cisco 1721 Cisco 1751 Cisco 1760 Cisco 1800 series (modular) Cisco 2600 series Cisco 2800 series Cisco 3700 series Cisco 3800 series	<i>DSL Interface Cards</i>
1-port ADSL-over-POTS with dying gasp HWIC	HWIC-1ADSL	Cisco 1800 series (modular) Cisco 2800 series Cisco 3800 series	<i>DSL Interface Cards</i>
1-port ADSL-over-ISDN with dying gasp HWIC	HWIC-1ADSLI	Cisco 1800 series (modular) Cisco 2800 series Cisco 3800 series	<i>DSL Interface Cards</i>
1-port ADSL-over-POTS with dying gasp HWIC with backup ISDN port	HWIC-1ADSL-B/ST	Cisco 1800 series (modular) Cisco 2800 series Cisco 3800 series	<i>DSL Interface Cards</i>

Table 4 Platform Support for Cisco Interface Cards (continued)

Product Description	Cisco Product ID	Supported on Cisco Routers	See Document
1-port ADSL-over-ISDN with dying gasp HWIC with backup ISDN port	HWIC-1ADSLI-B/ST	Cisco 1800 series (modular) Cisco 2800 series Cisco 3800 series	<i>DSL Interface Cards</i>
1-port G.SHDSL WIC (two-wire only)	WIC-1SHDSL	Cisco 1721 Cisco 1751 Cisco 1760 Cisco 1800 series (modular) Cisco 2600 series Cisco 2800 series Cisco 3600 series Cisco 3700 series Cisco 3800 series	<i>DSL Interface Cards</i>
1-port G.SHDSL WIC (two- and four-wire), version 2	WIC-1SHDSL-V2	Cisco 1721 Cisco 1751 Cisco 1760 Cisco 2600 series Cisco 2800 series ² Cisco 3700 series Cisco 3800 series	<i>DSL Interface Cards</i>
1-port G.SHDSL WIC (two- and four-wire), version 3	WIC-1SHDSL-V3	Cisco 1721 Cisco 1751 Cisco 1760 Cisco 1841 Cisco 2600XM series Cisco 2691 Cisco 2800 series ² Cisco 3700 series Cisco 3800 series	<i>DSL Interface Cards</i>
2-port G.SHDSL WIC	HWIC-2SHDSL	Cisco 1841 router Cisco 2800 series Cisco 3800 series	<i>DSL Interface Cards</i>
4-port G.SHDSL WIC	HWIC-4SHDSL	Cisco 1841 router Cisco 2800 series Cisco 3800 series	<i>DSL Interface Cards</i>
Ethernet Switch WAN Interface Cards			
4-port 10/100BASE-T Ethernet switch WIC	WIC-4ESW	Cisco 1721 Cisco 1751 Cisco 1760	<i>10/100BASE-T Ethernet Switch High-Speed Interface Cards</i>
4-port 10/100BASE-T Ethernet switch HWIC	HWIC-4ESW	Cisco 1800 series (modular) Cisco 2800 series Cisco 3800 series	<i>10/100BASE-T Ethernet Switch High-Speed Interface Cards</i>
4-port Ethernet switch HWIC with inline power	HWIC-4ESW-POE	Cisco 2800 series Cisco 3800 series	<i>10/100BASE-T Ethernet Switch High-Speed Interface Cards</i>
9-port 10/100BASE-T Ethernet switch HWIC	HWIC-D-9ESW	Cisco 2800 series Cisco 3800 series	<i>10/100BASE-T Ethernet Switch High-Speed Interface Cards</i>

Table 4 Platform Support for Cisco Interface Cards (continued)

Product Description	Cisco Product ID	Supported on Cisco Routers	See Document
9-port Ethernet switch HWIC with inline power	HWIC-D-9ESW-POE	Cisco 2800 series Cisco 3800 series	<i>10/100BASE-T Ethernet Switch High-Speed Interface Cards</i>
1-port Ethernet LAN WIC	WIC-1ENET	Cisco 1721 Cisco 1751 Cisco 1760	<i>LAN Interface Cards</i>
1-port Fast Ethernet HWIC	HWIC-1FE	Cisco 1841 router Cisco 2800 series Cisco 3800 series	<i>Fast Ethernet High-Speed WAN Interface Cards to a Network</i>
2-port Fast Ethernet HWIC	HWIC-2FE	Cisco 3800 series	<i>Fast Ethernet High-Speed WAN Interface Cards to a Network</i>
1-port Gigabit Ethernet HWIC	HWIC-1GE-SFP	Cisco 2800 series ² Cisco 3800 series	<i>Gigabit Ethernet High-Speed Interface Cards</i>
ISDN BRI WAN Interface Cards			
1-port ISDN BRI WIC with integrated NT1—U interface	WIC-1B-U	Cisco 1600 series ³ Cisco 1721 Cisco 1751 Cisco 1760 Cisco 2600 series Cisco 3600 series Cisco 3700 series Cisco ICS 7750	<i>ISDN WAN Interface Cards</i>
1-port ISDN BRI WIC with integrated NT1—U interface, version 2	WIC-1B-U-V2	Cisco 1721 Cisco 1751 Cisco 1760 Cisco 1800 series (modular) Cisco 2600 series Cisco 2800 series Cisco 3600 series Cisco 3800 series	<i>ISDN WAN Interface Cards</i>
1-port ISDN BRI WIC with S/T interface	WIC-1B-S/T	Cisco 1600 series ³ Cisco 1721 Cisco 1751 Cisco 1760 Cisco 2600 series Cisco 3600 series Cisco 3700 series Cisco ICS 7750	<i>ISDN WAN Interface Cards</i>
1-port ISDN BRI WIC with S/T interface, version 3	WIC-1B-S/T-V3	Cisco 1721 Cisco 1751 Cisco 1760 Cisco 1800 series (modular) Cisco 2600 series Cisco 2800 series Cisco 3600 series Cisco 3800 series	<i>ISDN WAN Interface Cards</i>

Table 4 Platform Support for Cisco Interface Cards (continued)

Product Description	Cisco Product ID	Supported on Cisco Routers	See Document
1-port ISDN BRI leased line WIC	WIC-1B-S/T-LL	Cisco 1600 series ⁴	<i>ISDN WAN Interface Cards</i>
Serial WAN Interface Cards			
1-port serial WIC	WIC-1T	Cisco 1600 series Cisco 1721 Cisco 1751 Cisco 1760 Cisco 1800 series (modular) Cisco 2600 series Cisco 2800 series Cisco 3600 series Cisco 3700 series Cisco 3800 series Cisco ICS 7750	<i>Serial Interface Cards</i>
2-port serial WIC	WIC-2T	Cisco 1721 Cisco 1751 Cisco 1760 Cisco 1800 series (modular) Cisco 2600 series Cisco 2800 series Cisco 3600 series Cisco 3700 series Cisco 3800 series Cisco ICS 7750	<i>Serial Interface Cards</i>
2-port asynchronous/ synchronous serial WIC	WIC-2A/S	Cisco 1721 Cisco 1751 Cisco 1760 Cisco 1800 series (modular) Cisco 2600 series Cisco 2800 series Cisco 3600 series Cisco 3700 series Cisco 3800 series Cisco ICS 7750 Cisco MWR 1941-DC	<i>Serial Interface Cards</i>
4-port multiprotocol serial HWIC	HWIC-4T	Cisco 1800 series (modular) Cisco 2800 series Cisco 3800 series	<i>Serial Interface Cards</i>
4-port multiprotocol low speed asynchronous/ synchronous serial HWIC	HWIC-4A/S	Cisco 1800 series (modular) Cisco 2800 series Cisco 3800 series	<i>Serial Interface Cards</i>
8-port RS-232 asynchronous/ synchronous serial HWIC	HWIC-8A-RS232	Cisco 1800 series (modular) Cisco 2800 series Cisco 3800 series	<i>Serial Interface Cards</i>
8-port asynchronous serial HWIC	HWIC-8A	Cisco 1800 series (modular) Cisco 2800 series Cisco 3800 series	<i>Serial Interface Cards</i>

Table 4 Platform Support for Cisco Interface Cards (continued)

Product Description	Cisco Product ID	Supported on Cisco Routers	See Document
16-port asynchronous serial HWIC	HWIC-16A	Cisco 2800 series Cisco 3800 series	<i>Serial Interface Cards</i>
T1, E1, and G.703 Multiflex Trunk Voice and WAN Interface Cards			
1-port T1 RJ-48 multiflex trunk VWIC	VWIC-1MFT-T1	Cisco 1721 ⁵ Cisco 1751 Cisco 1760 Cisco 1800 series (modular) Cisco 2600 series Cisco 2800 series Cisco 3600 series Cisco 3700 series Cisco 3800 series Cisco ICS 7750	<i>Voice Interface Cards</i>
2-port T1 RJ-48 multiflex trunk VWIC	VWIC-2MFT-T1	Cisco 1721 ⁵ Cisco 1751 Cisco 1760 Cisco 1800 series (modular) Cisco 2600 series Cisco 2800 series Cisco 3600 series Cisco 3700 series Cisco 3800 series Cisco ICS 7750	<i>Voice Interface Cards</i>
2-port T1 RJ-48 multiflex trunk VWIC with drop-and-insert capability	VWIC-1MFT-T1-DI	Cisco 1721 ⁵ Cisco 1751 Cisco 1760 Cisco 1800 series (modular) Cisco 2600 series Cisco 2800 series Cisco 3600 series Cisco 3700 series Cisco 3800 series	<i>Voice Interface Cards</i>
1-port E1 RJ-48 multiflex trunk VWIC	VWIC-1MFT-E1	Cisco 1721 ⁵ Cisco 1751 Cisco 1760 Cisco 1800 series (modular) Cisco 2600 series Cisco 2800 series Cisco 3600 series Cisco 3700 series Cisco 3800 series Cisco ICS 7750	<i>Voice Interface Cards</i>

Table 4 Platform Support for Cisco Interface Cards (continued)

Product Description	Cisco Product ID	Supported on Cisco Routers	See Document
2-port E1 RJ-48 multiflex trunk VWIC	VWIC-2MFT-E1	Cisco 1721 ⁵ Cisco 1751 Cisco 1760 Cisco 1800 series (modular) Cisco 2600 series Cisco 2800 series Cisco 3600 series Cisco 3700 series Cisco 3800 series Cisco ICS 7750	<i>Voice Interface Cards</i>
1-port T1/E1 RJ-48 multiflex trunk VWIC with hardware echo cancellation, version 2	VWIC2-1MFT-T1/E1	Cisco 1721 ⁵ Cisco 1751 Cisco 1760 Cisco 1800 series (modular) Cisco 2600 series Cisco 2800 series Cisco 3600 series Cisco 3700 series Cisco 3800 series	<i>Voice Interface Cards</i>
2-port T1/E1 RJ-48 multiflex trunk VWIC with hardware echo cancellation, version 2	VWIC2-2MFT-T1/E1	Cisco 1721 ⁵ Cisco 1751 Cisco 1760 Cisco 1800 series (modular) Cisco 2600 series Cisco 2800 series Cisco 3600 series Cisco 3700 series Cisco 3800 series	<i>Voice Interface Cards</i>
2-port E1 RJ-48 multiflex trunk VWIC with drop-and-insert capability	VWIC-2MFT-E1-DI	Cisco 1721 ⁵ Cisco 1751 Cisco 1760 Cisco 1800 series (modular) Cisco 2600 series Cisco 2800 series Cisco 3600 series Cisco 3700 series Cisco 3800 series	<i>Voice Interface Cards</i>
1-port G.703 RJ-48 multiflex trunk VWIC	VWIC-1MFT-G703	Cisco 1721 ⁵ Cisco 1751 Cisco 1760 Cisco 1800 series (modular) Cisco 2600 series Cisco 2800 series Cisco 3600 series Cisco 3700 series Cisco 3800 series	<i>Voice Interface Cards</i>

Table 4 Platform Support for Cisco Interface Cards (continued)

Product Description	Cisco Product ID	Supported on Cisco Routers	See Document
2-port G.703 RJ-48 multiflex trunk VWIC	VWIC-2MFT-G703	Cisco 1721 ⁵ Cisco 1751 Cisco 1760 Cisco 1800 series (modular) Cisco 2600 series Cisco 2800 series Cisco 3600 series Cisco 3700 series Cisco 3800 series	<i>Voice Interface Cards</i>
1-port G.703 RJ-48 multiflex trunk VWIC with hardware echo cancellation, version 2	VWIC2-1MFT-G703	Cisco 1721 ⁵ Cisco 1751 Cisco 1760 Cisco 1800 series (modular) Cisco 2600 series Cisco 2800 series Cisco 3600 series Cisco 3700 series Cisco 3800 series	<i>Voice Interface Cards</i>
2-port G.703 RJ-48 multiflex trunk VWIC with hardware echo cancellation, version 2	VWIC2-2MFT-G703	Cisco 1721 ⁵ Cisco 1751 Cisco 1760 Cisco 1800 series (modular) Cisco 2600 series Cisco 2800 series Cisco 3600 series Cisco 3700 series Cisco 3800 series	<i>Voice Interface Cards</i>
2-port T1/fractional T1 multiflex trunk VWIC with drop-and-insert capability and integrated CSU/DSU	VWIC-2MFT-T1-DIR	Cisco MWR 1941-DC	<i>VWIC-2MFT-T1-DIR, VWIC-2MFT-E1-DIR Installation Instructions</i>
2-port E1/fractional E1 multiflex trunk VWIC with drop-and-insert capability and integrated DSU	VWIC-2MFT-E1-DIR	Cisco MWR 1941-DC	<i>VWIC-2MFT-T1-DIR, VWIC-2MFT-E1-DIR Installation Instructions</i>
2-port T1/E1 radio access network optimization VWIC	VWIC-2T1/E1-RAN	Cisco MWR 1941-DC	<i>Cisco 2-port T1/E1-RAN Installation Instructions</i>
Voice Interface Cards			
2-port Direct Inward Dial (DID) VIC	VIC-2DID	Cisco 1751 Cisco 1760 Cisco 2600 series Cisco 2800 series Cisco 3600 series Cisco ICS 7750	<i>Voice Interface Cards</i>
1-port digital VIC for Japan	VIC-1J1	Cisco 2800 series ²	<i>Voice Interface Cards</i>

Table 4 Platform Support for Cisco Interface Cards (continued)

Product Description	Cisco Product ID	Supported on Cisco Routers	See Document
4-port FXS or DID VIC	VIC-4FXS/DID	Cisco 1751 Cisco 1760 Cisco 2600XM series Cisco 2691 Cisco 2800 series Cisco 3600 series Cisco 3700 series Cisco 3800 series Cisco ICS 7750	<i>Voice Interface Cards</i>
2-port FXS VIC	VIC-2FXS ⁶	Cisco 1751 Cisco 1760 Cisco 2600 series Cisco 3600 series Cisco 3700 series Cisco 3800 series Cisco ICS 7750	<i>Voice Interface Cards</i>
2-port FXS VIC, version 2	VIC2-2FXS ⁶	Cisco 1751 Cisco 1760 Cisco 2600XM series Cisco 2800 series Cisco 3640 routers Cisco 3660 routers Cisco 3700 series Cisco 3800 series	<i>Voice Interface Cards</i>
2-port FXO VIC for Europe	VIC-2FXO-EU ⁶	Cisco 1751 Cisco 1760 Cisco 2600 series Cisco 3600 series Cisco 3700 series	<i>Voice Interface Cards</i>
2-port FXO VIC for the United States	VIC-2FXO-M1 ⁶	Cisco 1751 Cisco 1760 Cisco 2600 series Cisco 3600 series Cisco 3700 series Cisco ICS 7750	<i>Voice Interface Cards</i>
2-port FXO VIC for Europe	VIC-2FXO-M2 ⁶	Cisco 1751 Cisco 1760 Cisco 2600 series Cisco 3600 series Cisco 3700 series Cisco ICS 7750	<i>Voice Interface Cards</i>
2-port FXO VIC for Australia	VIC-2FXO-M3 ⁶	Cisco 1751 Cisco 1760 Cisco 2600 series Cisco 3600 series Cisco 3700 series Cisco ICS 7750	<i>Voice Interface Cards</i>

Table 4 Platform Support for Cisco Interface Cards (continued)

Product Description	Cisco Product ID	Supported on Cisco Routers	See Document
2-port FXO VIC	VIC-2FXO ⁶	Cisco 1751 Cisco 1760 Cisco 2600 series Cisco 3600 series Cisco 3700 series Cisco 3800 series Cisco ICS 7750	<i>Voice Interface Cards</i>
2-port FXO (universal) VIC, version 2	VIC2-2FXO ⁶	Cisco 1751 Cisco 1760 Cisco 2600XM series Cisco 2800 series Cisco 3640 routers Cisco 3660 routers Cisco 3700 series Cisco 3800 series	<i>Voice Interface Cards</i>
4-port FXO VIC for the United States	VIC-4FXO-M1	Cisco ICS 7750	<i>Voice Interface Cards</i>
4-port FXO (universal) VIC, version 2	VIC2-4FXO ⁶	Cisco 1751 Cisco 1760 Cisco 2600XM series Cisco 2800 series Cisco 3640 routers Cisco 3660 routers Cisco 3700 series Cisco 3800 series Cisco ICS 7750	<i>Voice Interface Cards</i>
2-port E&M VIC	VIC-2E/M ⁶	Cisco 1751 Cisco 1760 Cisco 2600 series Cisco 2800 series ² Cisco 3600 series Cisco 3700 series Cisco 3800 series Cisco ICS 7750	<i>Voice Interface Cards</i>
2-port E&M VIC, version 2	VIC2-2E/M ⁶	Cisco 1751 Cisco 1760 Cisco 2600XM series Cisco 2800 series Cisco 3640 routers Cisco 3660 routers Cisco 3700 series Cisco 3800 series Cisco ICS 7750	<i>Voice Interface Cards</i>
2-port ISDN BRI S/T (NT and TE) VIC	VIC-2BRI-NT/TE	Cisco ICS 7750	<i>Voice Interface Cards</i>

Table 4 Platform Support for Cisco Interface Cards (continued)

Product Description	Cisco Product ID	Supported on Cisco Routers	See Document
2-port ISDN BRI S/T (NT and TE) VIC, version 2	VIC2-2BRI-NT/TE	Cisco 1751 Cisco 1760 Cisco 2600XM series Cisco 2800 series Cisco 3660 routers Cisco 3800 series Cisco ICS 7750	<i>Voice Interface Cards</i>
2-port ISDN BRI S/T TE VIC	VIC-2BRI-S/T-TE ⁶	Cisco 2600 series Cisco 3600 series Cisco 3700 series	<i>Voice Interface Cards</i>
2-port ISDN BRI S/T TE VIC, version 2	VIC2-2BRI-S/T-TE ⁶	Cisco 3640 routers Cisco 3660 routers Cisco 3700 series Cisco 3800 series	<i>Voice Interface Cards</i>
2-port CAMA VIC	VIC-2CAMA ⁶	Cisco 2600 series Cisco 3600 series	<i>Voice Interface Cards</i>
Wireless Interface Cards			
Access point HWIC for North America	HWIC-AP-G-A	Cisco 1841 Cisco 2801 Cisco 2811 Cisco 2821 Cisco 2851 Cisco 3825 Cisco 3845	<i>Access Point High-Speed WAN Interface Cards</i>
Access point HWIC for Europe	HWIC-AP-G-E	Cisco 1841 Cisco 2801 Cisco 2811 Cisco 2821 Cisco 2851 Cisco 3825 Cisco 3845	<i>Access Point High-Speed WAN Interface Cards</i>
Access point HWIC for Japan	HWIC-AP-G-J	Cisco 1841 Cisco 2801 Cisco 2811 Cisco 2821 Cisco 2851 Cisco 3825 Cisco 3845	<i>Access Point High-Speed WAN Interface Cards</i>

Table 4 Platform Support for Cisco Interface Cards (continued)

Product Description	Cisco Product ID	Supported on Cisco Routers	See Document
GSM 3G Wireless WAN HWIC	HWIC-3G-GSM	Cisco 1841 Cisco 2801 Cisco 2811 Cisco 2821 Cisco 2851 Cisco 3825 Cisco 3845	<i>3G Wireless WAN Interface Cards to a Network</i>
CDMA 3G Wireless WAN HWIC	HWIC-3G-CDMA	Cisco 1841 Cisco 2801 Cisco 2811 Cisco 2821 Cisco 2851 Cisco 3825 Cisco 3845	<i>3G Wireless WAN Interface Cards to a Network</i>

1. Supported on Cisco 2600XM and Cisco 2691 routers only.
2. Not supported on Cisco 2801 routers.
3. Not supported on Cisco 1603 and Cisco 1604 routers.
4. Supported on Cisco 1603 and Cisco 1604 routers only.
5. Cisco 1721 router supports these cards in data mode only.
6. In Cisco 1751 and Cisco 1760 routers, can be directly installed into a router interface slot. For other routers, cannot be installed directly into Cisco router interface card slots. Install in a voice network module (NM-1V or NM-2V).

Related Documents

Cisco product documentation is available online at www.cisco.com (also known as Cisco.com), and is accessible through multiple navigation paths.

To access the documents and tools described in this section, you must have an account on Cisco.com. If you do not have an account or have forgotten your username or password, click **Cancel** at the login dialog box and follow the instructions that appear.



Timesaver

To access Cisco product documentation as it appeared on Cisco Connection Online (CCO), click on the Technical Documentation link in the right-hand Quick Links column on the Cisco.com homepage.

To print a document in its original page format, access the online document, and click the PDF icon.



Tip

Some authors provide a full-length “book” PDF, usually located above or below the links to the book chapter files on the main book index page. Use this book-length PDF to generate printed copies of the entire book.

Hardware Documentation

Cisco hardware documentation for Cisco access routers provides the following three categories of information:

- Hardware installation—Basic to advanced hardware installation procedures
- Hardware reference information and specifications—Dimensions, operating environment, cable pinouts
- Regulatory compliance and safety information—Safety warnings translated into multiple languages and statements of compliance with regulatory requirements from various countries around the world

Installation Documents

To find chassis installation instructions for any Cisco router, access the documents located at **Products and Solutions > Routers and Routing Systems > Router series you are using > Technical Documentation > Installation Guides**.

To find installation instructions for Cisco network modules, access the *Cisco Network Modules Hardware Installation Guide* located at **Products and Solutions > Interfaces and Modules > Network Modules > Technical Documentation > Module Installation Guides**.

To find installation instructions for Cisco interface cards, access the *Cisco Interface Cards Hardware Installation Guide* located at **Products and Solutions > Interfaces and Modules > All Interfaces and Modules > Cisco Interface Cards > Technical Documentation > Module Installation Guides**.

To find installation instructions for Cisco small form-factor pluggable modules (SFPs), access the documents located at **Products and Solutions > Interfaces and Modules > Cisco SFPs > Technical Documentation > Installation Guides**.

To find installation instructions for Cisco coarse wavelength-division multiplexing (CWDM) SFPs, access the documents located at **Products and Solutions > Interfaces and Modules > Cisco CWDM GBIC/SFP > Technical Documentation > Module Installation Guides**.



Note Installation instructions for the Cisco CWDM Passive Optical System are also located in this index.

Reference Documents

To find cabling specifications for Cisco modular access routers, access the *Cisco Modular Access Router Cable Specifications* located at **Products and Solutions > Routers and Routing Systems > 2600 Series > Technical Documentation > Technical References**.

Regulatory Compliance and Safety Information Documents

To find regulatory compliance and safety information for a Cisco router, access the documents located at **Products and Solutions > Routers and Routing Systems > Router series you are using > Product Literature > Regulatory Approvals and Compliance**.

To find regulatory compliance and safety information for Cisco network modules and Cisco interface cards used on Cisco access routers, access the documents located at **Products and Solutions > Interfaces and Modules > Product Literature > Regulatory Approvals and Compliance**.

Cisco IOS Software Documentation

Cisco IOS software documentation provides the following categories of information:

- Software configuration—Basic to advanced software configuration procedures, sample configurations
- Software references—Command references, system message guides
- Software release information—Supported products, caveats
- Software release tools—Cisco Feature Navigator II, Cisco IOS Upgrade Planner, software downloads, security notices and advisories

Cisco IOS Software Configuration Documents

To find initial configuration instructions specific to the Cisco router you are using, access the documents located at **Products and Solutions > Routers > Router series you are using > Technical Documentation > Configuration Guides.**

To find configuration examples specific to the Cisco router you are using, access the documents located at **Products and Solutions > Routers > Router series you are using > Technical Documentation > Configuration Examples.**

To find advanced configuration instructions for a specific feature, access the documents located at **Products and Solutions > Cisco IOS Software > Cisco IOS release you are using > Cisco IOS Software Releases > Technical Documentation > Feature Guides.**

Cisco IOS Software Reference Documents

To find command reference information for the Cisco IOS software release you are using, access the documents located at **Products and Solutions > Cisco IOS Software > Cisco IOS release you are using > Cisco IOS Software Releases > Technical Documentation > Command References.**



Timesaver

You can also use the online Command Lookup tool, located at **Technical Support > Tools & Utilities > Configuration Tools.**

To find system message information for the Cisco IOS software release you are using, access the documents located at **Products and Solutions > Cisco IOS Software > Cisco IOS release you are using > Cisco IOS Software Releases > Technical Documentation > System Message Guides.**

Cisco IOS Software Release Documents and Tools

To find Cisco IOS software release information for the Cisco IOS software release you are using, access the documents located at **Products and Solutions > Cisco IOS Software > Cisco IOS release you are using > Cisco IOS Software Releases > Technical Documentation > Release Notes.**

To view Cisco IOS software features by release, or to compare two different Cisco IOS releases, access Cisco Feature Navigator II, located at **Products and Solutions > Cisco IOS Software > General Information.**

To download Cisco IOS software, or to locate license agreements and warranty information for a Cisco IOS software release, access the Software Center, located at **Technical Support > Downloads.**

To plan for a Cisco IOS upgrade, access the Cisco IOS Upgrade Planner, located at **Technical Support > Downloads > Cisco IOS Upgrade Planner**.

To view Cisco IOS security advisories that might apply to your product, access the *Cisco Product Security Advisories and Notices* website located at http://www.cisco.com/en/US/products/products_security_advisories_listing.html.



Timesaver

You can also sign up to receive e-mail alerts using the Product Alert Tool, located at **Technical Support > Tools and Utilities > Configuration Tools >**.

Where to Go Next

For interface card installation information, go to *Installing Cisco Interface Cards in Cisco Access Routers*

For regulatory compliance and safety information, see the *Cisco Network Modules and Interface Cards Regulatory Compliance and Safety Information* document.

For hardware information about specific interface cards, use Table 4 on page 15 to locate the appropriate chapter.

Obtaining Documentation, Obtaining Support, and Security Guidelines

For information on obtaining documentation, obtaining support, providing documentation feedback, security guidelines, and also recommended aliases and general Cisco documents, see the monthly *What's New in Cisco Product Documentation*, which also lists all new and revised Cisco technical documentation, at:

<http://www.cisco.com/en/US/docs/general/whatsnew/whatsnew.html>

CCVP, the Cisco logo, and Welcome to the Human Network are trademarks of Cisco Systems, Inc.; Changing the Way We Work, Live, Play, and Learn is a service mark of Cisco Systems, Inc.; and Access Registrar, Aironet, Catalyst, CCDA, CCDP, CCIE, CCIP, CCNA, CCNP, CCSP, Cisco, the Cisco Certified Internetwork Expert logo, Cisco IOS, Cisco Press, Cisco Systems, Cisco Systems Capital, the Cisco Systems logo, Cisco Unity, Enterprise/Solver, EtherChannel, EtherFast, EtherSwitch, Fast Step, Follow Me Browsing, FormShare, GigaDrive, HomeLink, Internet Quotient, IOS, iPhone, IP/TV, iQ Expertise, the iQ logo, iQ Net Readiness Scorecard, iQuick Study, LightStream, Linksys, MeetingPlace, MGX, Networkers, Networking Academy, Network Registrar, PIX, ProConnect, ScriptShare, SMARTnet, StackWise, The Fastest Way to Increase Your Internet Quotient, and TransPath are registered trademarks of Cisco Systems, Inc. and/or its affiliates in the United States and certain other countries.

All other trademarks mentioned in this document or Website are the property of their respective owners. The use of the word partner does not imply a partnership relationship between Cisco and any other company. (0711R)

Any Internet Protocol (IP) addresses used in this document are not intended to be actual addresses. Any examples, command display output, and figures included in the document are shown for illustrative purposes only. Any use of actual IP addresses in illustrative content is unintentional and coincidental.

© 2007 Cisco Systems, Inc. All rights reserved.



Installing Cisco Interface Cards in Cisco Access Routers

Revised: 6/7/07, OL-12842-01

Overview

This document provides information you should know before and during installation of Cisco interface cards in Cisco access routers, and contains the following sections:

- Recommended Practices for Cisco Interface Cards, page 1
- Installing Cisco Interface Cards in Cisco Access Routers, page 5
- Installing Cisco Interface Cards in Cisco Network Modules, page 18
- Removing or Replacing Cisco Interface Cards for Cisco Access Routers, page 20
- Installing Cisco Interface Cards on the Cisco ICS 7750, page 21
- Installing Other Accessories in Cisco Interface Cards, page 25
- Where to Go Next, page 27

Recommended Practices for Cisco Interface Cards

This section describes recommended practices for safe and effective installation of the hardware described in this document, and includes the following sections:

- Safety Recommendations
- Preventing Electrostatic Discharge Damage
- General Maintenance Guidelines for Cisco Interface Cards

Safety warnings included in this section apply to all Cisco interface cards used on Cisco access routers.



Note

Recommendations and warnings for specific interface cards are documented in the chapter specific to the interface card.

Safety Recommendations

To prevent hazardous conditions, follow these safety recommendations while working with this equipment:

- Keep tools away from walk areas where you or others could fall over them.
- Do not wear loose clothing around the router. Fasten your tie or scarf and roll up your sleeves to prevent clothing from being caught in the chassis.
- Wear safety glasses when working under any conditions that might be hazardous to your eyes.
- Locate the emergency power-off switch in the room before you start working. If an electrical accident occurs, shut the power off.
- Before working on the router, turn off the power and unplug the power cord.
- Disconnect all power sources before doing the following:
 - Installing or removing a router chassis
 - Working near power supplies
- Do not work alone if potentially hazardous conditions exist.
- Always check that power is disconnected from a circuit.
- Remove possible hazards from your work area, such as damp floors, ungrounded power extension cables, or missing safety grounds.
- If an electrical accident occurs, proceed as follows:
 - Use caution; do not become a victim yourself.
 - Turn off power to the room using the emergency power-off switch.
 - If possible, send another person to get medical aid. Otherwise, determine the condition of the victim and then call for help.
 - Determine if the person needs rescue breathing or external cardiac compressions; then take appropriate action.

Preventing Electrostatic Discharge Damage

Electrostatic discharge can damage equipment and impair electrical circuitry. Electrostatic discharge occurs when electronic printed circuit cards, such as those used in Cisco interface cards, are improperly handled and can result in complete or intermittent equipment failure. Always observe the following electrostatic discharge damage (ESD) prevention procedures when installing, removing, and replacing Cisco network modules, Cisco interface cards, Cisco expansion modules, or other electronic printed circuit cards:

- Make sure that the router chassis is electrically connected to earth ground.
- Wear an ESD-preventive wrist strap, and make sure that it makes good contact with your skin.

- Connect the wrist strap clip to an unpainted portion of the chassis frame to channel unwanted ESD voltages to ground.

**Caution**

The wrist strap and clip must be used correctly to ensure proper ESD protection. Periodically confirm that the resistance value of the ESD-preventive wrist strap is between 1 and 10 megohms (Mohm).

- If no wrist strap is available, ground yourself by touching the metal part of the router chassis.

General Maintenance Guidelines for Cisco Interface Cards

The following maintenance guidelines apply to Cisco interface cards:

- Keep the router chassis area clear and dust-free during and after installation.
- If you remove the chassis cover for any reason, store it in a safe place.
- Do not perform any action that creates a hazard to people or makes equipment unsafe.
- Keep walk areas clear to prevent falls or damage to equipment.
- Follow installation and maintenance procedures as documented by Cisco Systems, Inc.

Safety Warnings for Cisco Interface Cards

The following safety warning statements apply to all hardware procedures involving Cisco interface cards for Cisco access routers. Translations of these warnings are available in the *Cisco Network Modules and Interface Cards Regulatory Compliance and Safety Information* document, which ships with all individual Cisco interface card orders, and is also available online.

**Warning**

Before working on a chassis or working near power supplies, unplug the power cord on AC units; disconnect the power at the circuit breaker on DC units. Statement 12

**Warning**

Two people are required to lift the chassis. Grasp the chassis underneath the lower edge and lift with both hands. To prevent injury, keep your back straight and lift with your legs, not your back. To prevent damage to the chassis and components, never attempt to lift the chassis with the handles on the power supplies or on the interface processors, or by the plastic panels on the front of the chassis. These handles were not designed to support the weight of the chassis. Statement 194

**Warning**

Only trained and qualified personnel should be allowed to install or replace this equipment. Statement 1030

**Warning**

Ultimate disposal of this product should be handled according to all national laws and regulations. Statement 1040

The following warnings apply in Australia:



Warning

Do not touch the power supply when the power cord is connected. For systems with a power switch, line voltages are present within the power supply even when the power switch is OFF and the power cord is connected. For systems without a power switch, line voltages are present within the power supply when the power cord is connected. Statement 4



Warning

Before working on equipment that is connected to power lines, remove jewelry (including rings, necklaces, and watches). Metal objects will heat up when connected to power and ground and can cause serious burns or weld the metal object to the terminals. Statement 43



Warning

This equipment is to be installed and maintained by service personnel only as defined by AS/NZS 3260 Clause 1.2.14.3 Service Personnel. Statement 88



Warning

This equipment will be inoperable when mains power fails. Statement 198



Warning

Incorrect connection of this or connected equipment to a general purpose outlet could result in a hazardous situation. Statement 212



Warning

Because invisible laser radiation may be emitted from the aperture of the port when no fiber cable is connected, avoid exposure to laser radiation and do not stare into open apertures. Statement 125



Warning

Do not work on the system or connect or disconnect cables during periods of lightning activity. Statement 1001



Warning

To avoid electric shock, do not connect safety extra-low voltage (SELV) circuits to telephone-network voltage (TNV) circuits. LAN ports contain SELV circuits, and WAN ports contain TNV circuits. Both LAN and WAN ports may use RJ-45 connectors. Use caution when connecting cables. Statement 1021



Warning

Hazardous network voltages are present in WAN ports regardless of whether power to the router is OFF or ON. To avoid electric shock, use caution when working near WAN ports. When detaching cables, detach the end away from the router first. Statement 1026



Warning

Ultimate disposal of this product should be handled according to all national laws and regulations. Statement 1040

**Warning**

Before opening the chassis, disconnect the telephone-network cables to avoid contact with telephone-network voltages. Statement 1041

**Warning**

The telecommunications lines must be disconnected 1) before unplugging the main power connector and/or 2) while the housing is open. Statement 1043

Installing Cisco Interface Cards in Cisco Access Routers

This section describes installation tasks for Cisco interface cards used on Cisco access routers, and contains the following subsections:

- Preparing to Install Cisco Interface Cards
 - Do not install an ISDN BRI WAN interface card or an ISDN BRI network module in the same chassis as an ISDN PRI network module.
- Preparing Cisco Router Slots for Interface Card Installation
 - Installing Blank Faceplates
 - Removing Blank Faceplates
 - Installing Interface Card Slot Dividers
 - Removing Interface Card Slot Dividers
- Installing Single-Wide Interface Cards
- Installing Double-Wide Interface Cards

Preparing to Install Cisco Interface Cards

When installing an interface card in a Cisco access router, perform the following tasks:

Table 5 *Interface Card Hardware Installation Tasks for Cisco Access Routers*

	For All Cisco Access Routers Except Cisco 2800 and Cisco 3800 Series Routers	For Cisco 2800 Series and Cisco 3800 Series Routers
Step 1	Turn off power to the router.	Turn off power to the router.
Step 2	Remove the blank faceplate from the slot you plan to use. (See the “Removing Blank Faceplates” section on page 8.)	Remove the blank faceplate from the slot you plan to use. (See the “Removing Blank Faceplates” section on page 8.)
Step 3	Install the interface card. (See the “Installing Single-Wide Interface Cards” section on page 15.)	Prepare the slot for the interface card form factor you are installing. (See the “Preparing Cisco Router Slots for Interface Card Installation” section on page 6.)

Table 5 Interface Card Hardware Installation Tasks for Cisco Access Routers

	For All Cisco Access Routers Except Cisco 2800 and Cisco 3800 Series Routers	For Cisco 2800 Series and Cisco 3800 Series Routers
Step 4	Install blank faceplates where appropriate. (See the “Removing Blank Faceplates” section on page 8.)	Install the interface card. (See the “Installing Single-Wide Interface Cards” section on page 15 or the “Installing Double-Wide Interface Cards” section on page 16.)
Step 5	—	Install blank faceplates where appropriate. (See the “Removing Blank Faceplates” section on page 8.)

**Note**

Do not install an ISDN BRI WAN interface card or an ISDN BRI network module in the same chassis as an ISDN PRI network module.

Tools and Equipment Required During Cisco Interface Card Installation

You will need the following tools and equipment while working with Cisco interface cards:

- Number 1 Phillips screwdriver or a small flat-blade screwdriver
- ESD-preventive wrist strap
- (For routers using DC power) Tape to secure DC circuit breaker handle
- (For certain Cisco access routers) Voice network module for voice interface card installation

On some Cisco access routers, voice interface cards must be installed in voice network modules before being installed in the router. An additional network module or WAN interface card must be installed in the router to provide connections to an IP LAN or WAN.

Voice network modules are required for voice interface card installation in the following routers:

- Cisco 2600 series
- Cisco 3600 series
- Cisco 3700 series

**Tip**

For information on installing interface cards on network modules, see the “Installing Cisco Interface Cards in Cisco Network Modules” section on page 18.

Preparing Cisco Router Slots for Interface Card Installation

Several Cisco access routers have flexible interface card slots to support both single-wide and double-wide interface card form factors. Before installing an interface card, you must prepare the slot for the interface card’s form factor.

The following Cisco access routers may require interface card slot preparation prior to installation of the interface card:

- Cisco 2800 series routers
- Cisco 3800 series routers

**Tip**

For an introduction to Cisco interface card form factors, see the “Introduction to Cisco Interface Cards” section in *Cisco Interface Cards for Cisco Access Routers*.

To prepare an interface card slot for interface card installation, perform the tasks listed in Table 6.

Table 6 *Preparing Interface Card Slots for Installation*

	Double-wide to Single-wide Slot Conversion	Single-wide to Double-wide Slot Conversion
Step 1	Remove the blank faceplates from the slots you plan to use. (See the “Removing Blank Faceplates” section on page 8.)	Remove blank faceplates from the slots you plan to use. (See the “Removing Blank Faceplates” section on page 8.)
Step 2	Insert the slot divider. (See the “Installing Interface Card Slot Dividers” section on page 9.)	Remove the slot divider. (See the “Installing Interface Card Slot Dividers” section on page 9.)
Step 3	Install the interface card. (See the “Installing Single-Wide Interface Cards” section on page 15.)	Install the interface card. (See the “Installing Double-Wide Interface Cards” section on page 16.)

Installing Blank Faceplates

All empty chassis slots for network modules, extension modules, or interface cards must be covered with blank faceplates to ensure proper cooling and to prevent electromagnetic interference.

**Note**

Blank interface module faceplates are for single-wide interface card slots only.

To install a blank faceplate over an interface card slot set up for a double-wide interface card, you must prepare the slot as for single-wide interface cards. See Table 6 for information on preparing interface card slots for different interface card form factors.

To install a blank faceplate, perform the following steps:

- Step 1** (For interface card slots that contained double-wide interface cards) Install a slot divider in the center of the slot to create two single-wide interface card slots.
- Step 2** Align the captive screws with the threaded holes on the chassis. Using either a number 1 Phillips screwdriver or a small flat-blade screwdriver, tighten the captive screws until the blank faceplate is flush with the chassis. (See Figure 17.)

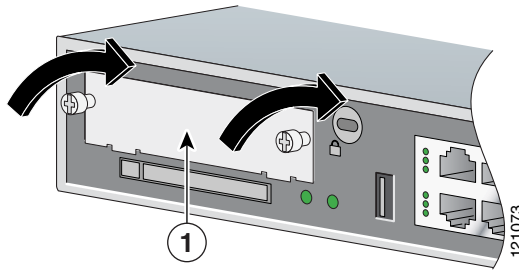
Figure 17 *Installing a Blank Interface Card Faceplate*

1	Blank interface card faceplate
----------	--------------------------------

Step 3 Repeat for every empty interface card slot.

Step 4 Continue with hardware installation tasks.

Removing Blank Faceplates

To remove blank faceplates, perform the following steps:

Step 1 Using either a number 1 Phillips screwdriver or a small flat-blade screwdriver, unscrew the captive screws and remove the blank faceplate from the chassis slot you plan to use. (See Figure 18.)

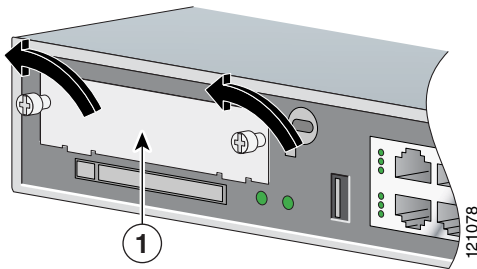
Figure 18 *Removing a Blank Interface Card Faceplate*

1	Blank interface card faceplate
----------	--------------------------------



Tip Save blank faceplates for future use.

Step 2 Continue with hardware installation tasks.

Installing Interface Card Slot Dividers

Interface card slot dividers are used to customize interface card slots for different Cisco interface card form factors. (See Figure 19 and Figure 20.) Interface card slot dividers are used on the following Cisco access routers:

- Cisco 2800 series
- Cisco 3800 series

To determine whether you need to install or remove slot dividers on your Cisco access router, see Table 6.

Figure 19 *Slot Divider for Interface Cards Slots on Cisco 2811, Cisco 2821, Cisco 2851, and Cisco 3825 Routers*

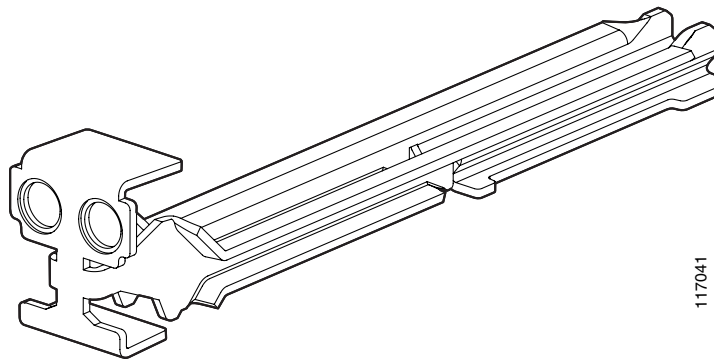
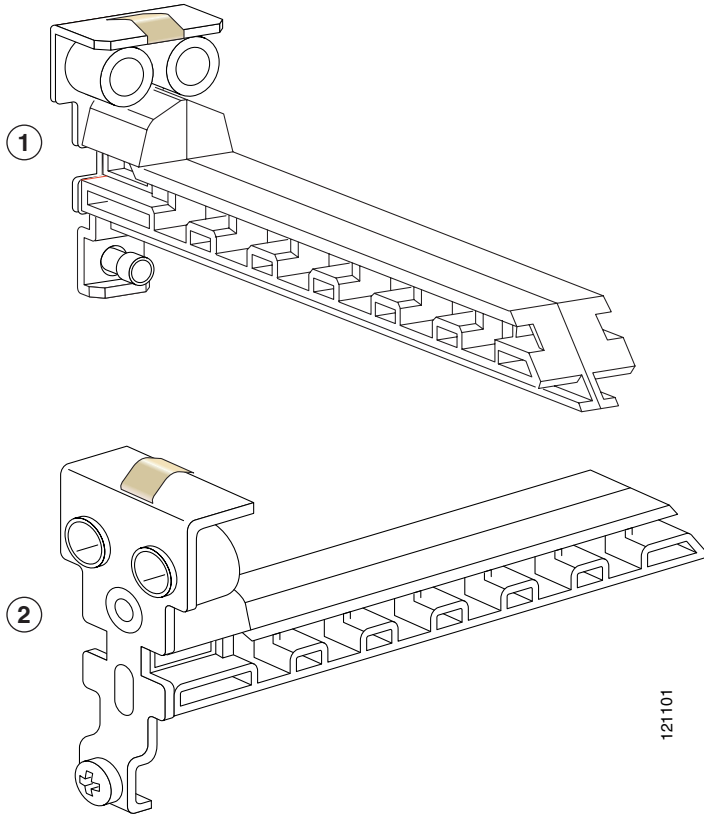

Figure 20 Slot Divider for Interface Cards Slots on Cisco 2801 and Cisco 3845 Routers



Installing Slot Dividers in Cisco 2811, Cisco 2821, Cisco 2851, and Cisco 3825 Series Routers

To install a slot divider in Cisco 2811, Cisco 2821, Cisco 2851, and Cisco 3825 series routers, perform the following steps:

- Step 1** Remove any installed interface cards and blank faceplates from the router slot you plan to use.
- Step 2** Guide the two halves of the slot divider between the two rails in the bottom of the interface card slot. (See Figure 21.)
- Step 3** Push the slot divider in until it seats and locks into place. When the slot divider is fully seated, its outer end is flush with the front panel of the router. (See Figure 22.)

Figure 21 *Inserting a Slot Divider into an Interface Card Slot*

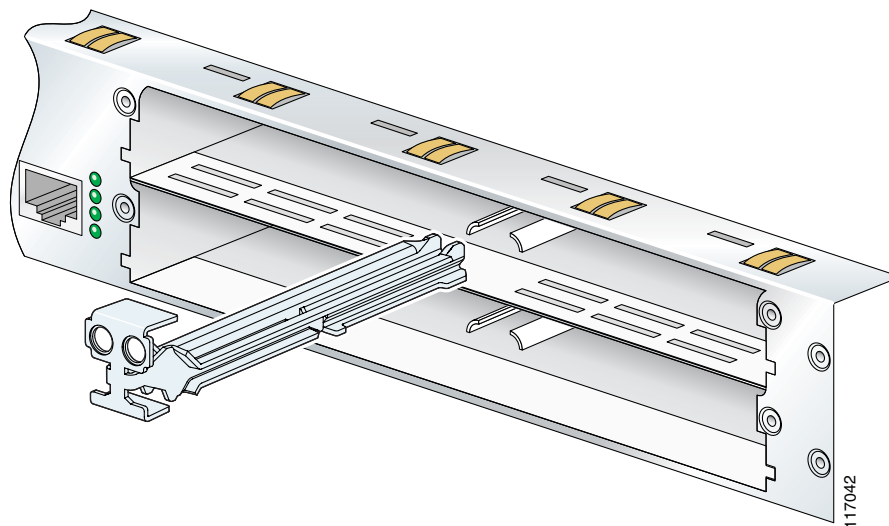

- Step 4** Gently pull the slot divider to check for complete seating. If properly seated, it does not come out. (See Figure 22.)

Figure 22 *Slot Divider Installed in an Interface Card Slot*

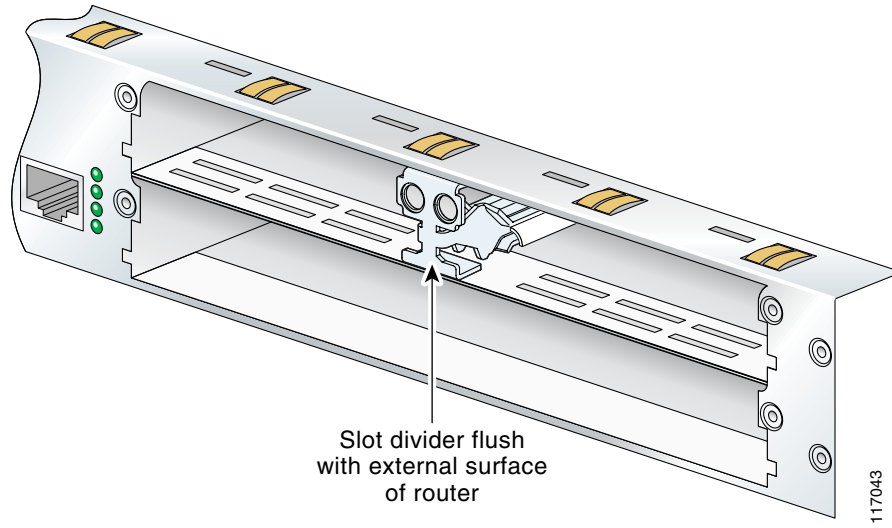

Installing Slot Dividers in Cisco 2801 and Cisco 3845 Routers

To install a slot divider in Cisco 2801 and Cisco 3845 routers, perform the following steps:

- Step 1** Guide the slot divider between the two rails in the bottom of the interface card slot. (See Figure 23.) Push the slot divider in until it is fully seated. When the slot divider is fully seated, its outer end is flush with the front panel of the router.

Figure 23 *Inserting a Slot Divider into an Interface Card Slot on a Cisco 2801 or Cisco 3845 Router*

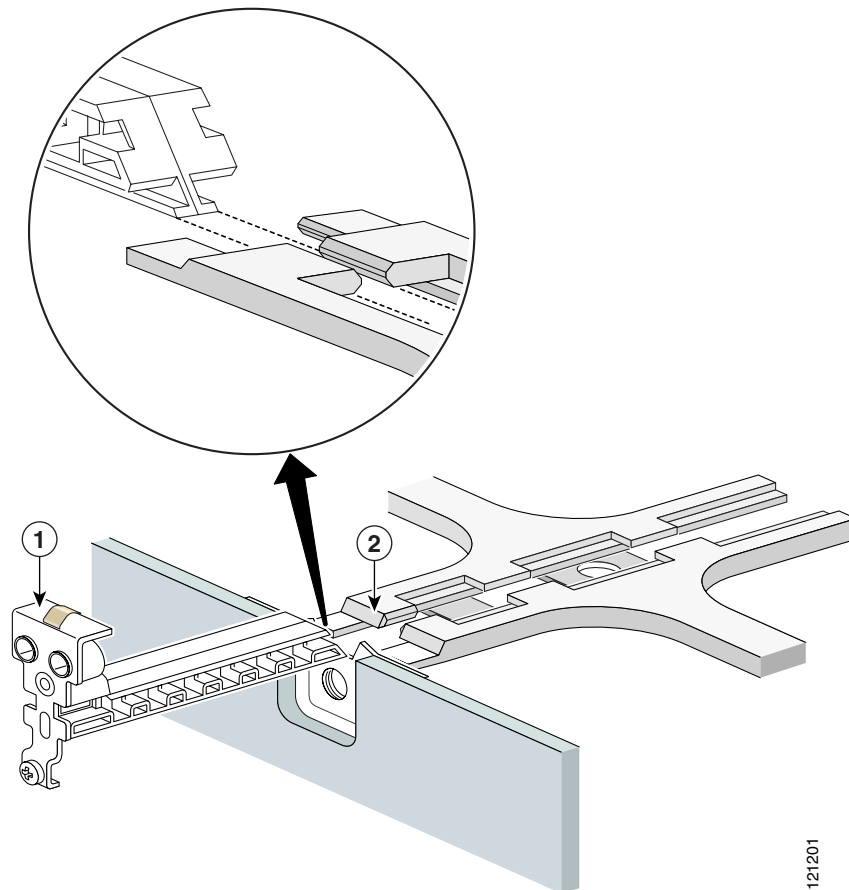

121201

1	Slot divider	2	Slot divider rails
----------	--------------	----------	--------------------

- Step 2** Tighten the retention screw on the slot divider.

Removing Interface Card Slot Dividers

Slot dividers are removed to permit use of double-wide interface cards in modular router slots. To determine whether you need to install or remove slot dividers on your Cisco access router, see Table 6.

To remove slot dividers from network module slots from Cisco 2811, Cisco 2821, Cisco 2851, and Cisco 3825 series routers, perform the following steps:

-
- Step 1** Remove any installed interface cards and blank faceplates from the router slot you plan to use.
 - Step 2** Reach into the interface card slots on both sides of the slot divider, and squeeze the two halves of the slot divider together. (See Figure 24.)

Figure 24 *Removing a Slot Divider from a Cisco 2811, Cisco 2821, Cisco 2851, or Cisco 3825 Series Router*

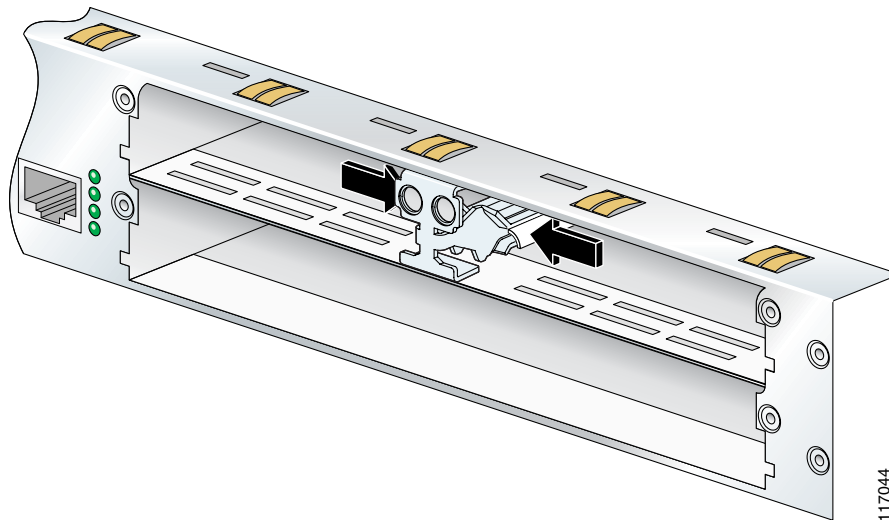

- Step 3** Pull the slot divider straight out of the interface card slot.
-

To remove slot dividers from network module slots from Cisco 2801 and Cisco 3845 routers, perform the following steps:

-
- Step 1** Remove any installed interface cards and blank faceplates from the router slot you plan to use.
 - Step 2** Loosen the retention screw on the slot divider.
 - Step 3** Pull the slot divider straight out of the interface card slot.
-

Installing Single-Wide Interface Cards

**Caution**

WAN interface cards and voice interface cards are not interchangeable. Voice interface cards cannot be installed in a WAN interface card slot or a 2-slot WAN network module, and WAN interface cards cannot be installed in voice network modules. To prevent damage to the card, confirm that the slot or network module you intend to use supports the kind of interface card you intend to install.

Interface cards can be installed either before or after mounting the router, whichever is most convenient. To install a single-wide interface card, follow these steps:

Step 1

Turn off electrical power to the router. Leave the power cable plugged in to channel ESD voltages to ground.

(For the Cisco MWR 1941-DC router) Turn off power by turning the DC power source circuit breaker to OFF. Tape the circuit breaker in the OFF position. To channel ESD voltages to ground, do not remove the wire from the ground lug.

**Warning**

Before performing any of the following procedures, ensure that power is removed from the DC circuit. To ensure that all power is OFF, locate the circuit breaker on the panel board that services the DC circuit, switch the circuit breaker to the OFF position, and tape the switch handle of the circuit breaker in the OFF position. Statement 7

Step 2

Remove all network cables, including telephone cables, from the router.

**Caution**

To prevent damage to the interface card, turn off electrical power and disconnect network cables from the chassis before inserting an interface card into an installed network module or router slot.

Step 3

Remove blank faceplates installed over the slot you intend to use. (See the “Removing Blank Faceplates” section on page 8.)

**Tip**

Save blank faceplates for future use.

Step 4

(For certain Cisco routers) Prepare the slot for the interface card form factor you are installing. (See the “Preparing Cisco Router Slots for Interface Card Installation” section on page 6.)

Step 5

Align the interface card with the guides in the chassis walls or slot divider and slide it gently into the slot (see Figure 25).

**Caution**

Do not touch the interface card board. Handle the interface card by the edges of the faceplate to reduce the risk of damage to the card.

**Tip**

(For Cisco 2600 series routers only) Install WAN interface cards in slot W0 first to avoid affecting your router configuration.

Figure 25 Installing Single-Wide Interface Cards in Cisco Access Routers

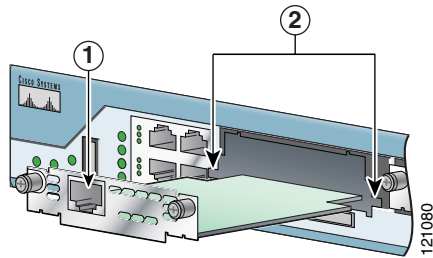

1	Interface card	2	Card guides
----------	----------------	----------	-------------

Step 6 Using the faceplate, push the interface card into place until you feel the edge connector seat securely into the connector on the router backplane. The interface card faceplate should contact the chassis rear panel.



Caution Do not connect cables to an interface card until you have installed it.

Step 7 Using a number 1 Phillips or flat-blade screwdriver, tighten the captive mounting screws on the interface card faceplate.

Step 8 Proceed with connecting the interface card to the network and powering up the router.



Tip See the “Where to Go Next” section on page 27 for information on locating additional hardware documentation.



Warning After wiring the DC power supply, remove the tape from the circuit breaker switch handle and reinstate power by moving the handle of the circuit breaker to the ON position. Statement 8

Installing Double-Wide Interface Cards

Interface cards can be installed either before or after mounting the router, whichever is most convenient. To install a double-wide interface card, follow these steps:

Step 1 Turn off electrical power to the router. Leave the power cable plugged in to channel ESD voltages to ground.

Step 2 Remove all network cables, including telephone cables, from the router.



Caution To prevent damage to the interface card, turn off electrical power and disconnect network cables from the chassis before inserting an interface card into an installed network module or router slot.

Step 3 Remove the blank faceplates installed over the slot you intend to use. (See the “Removing Blank Faceplates” section on page 8.)



Tip

Save blank faceplates for future use.

Step 4 Remove the slot divider. (See the “Removing Interface Card Slot Dividers” section on page 14.)

Step 5 Align the interface card with the guides in the chassis walls or slot divider, and slide it gently into the slot. (See Figure 26.)

Figure 26 *Installing Double-Wide Interface Cards in Cisco Access Routers*

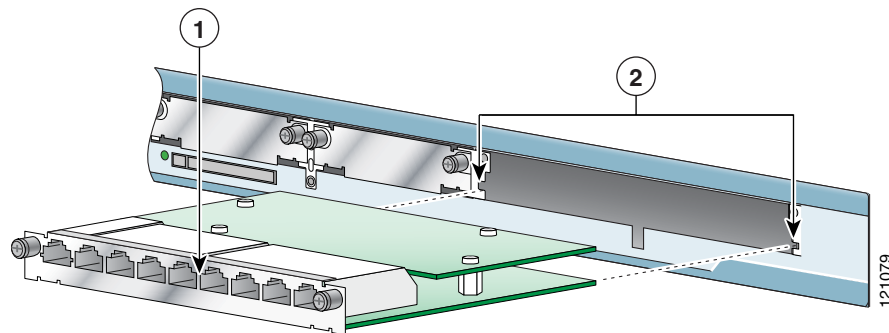

1	Interface card	2	Card guides
----------	----------------	----------	-------------



Caution

Do not touch the interface card board. Handle the interface card by the edges of the faceplate to reduce the risk of damage to the card.

Step 6 Using the faceplate, push the interface card into place until you feel the edge connector seat securely into the connector on the router backplane. The interface card faceplate should contact the chassis rear panel.



Caution

Do not connect cables to an interface card until you have installed it.

Step 7 Using a number 1 Phillips or flat-blade screwdriver, tighten the captive mounting screws on the interface card faceplate.

Step 8 Proceed with connecting the interface card to the network and powering up the router.



Tip

See the “Where to Go Next” section on page 27 for information on locating additional hardware documentation.

Installing Cisco Interface Cards in Cisco Network Modules



Caution

WAN interface cards and voice interface cards are not interchangeable. Voice interface cards cannot be installed in a WAN interface card slot or a two-slot WAN network module, and WAN interface cards cannot be installed in voice network modules. To prevent damage to the card, confirm that the slot or network module you intend to use supports the kind of interface card you intend to install.

Some Cisco network modules have one or two interface card slots, which support a variety of voice and data interface cards. To determine which interface cards are supported in your network module, see the *Cisco Network Modules Hardware Installation Guide*.

The following conditions apply to ISDN BRI and ISDN PRI network modules and interface cards:

- Do not install an ISDN BRI WAN interface card or an ISDN BRI network module in the same chassis as an ISDN PRI network module unless you are using Cisco IOS Release 11.3(3)T or a later release.
- Do not install newer BRI WAN interface cards in the same network module as older BRI WAN interface cards. To identify newer BRI WAN interface cards, examine the B-channel LEDs. Newer BRI WAN interface cards have B-channel LEDs that are arranged horizontally. Older BRI WAN interface cards have B-channel LEDs that are arranged vertically.

To install an interface card in a 1- or 2-slot network module, perform the following steps:

Step 1

Turn off electrical power to the router. Leave the power cable plugged in to channel ESD voltages to ground.

(For the Cisco MWR 1941-DC router) Turn off power by turning the DC power source circuit breaker to OFF. Tape the circuit breaker in the OFF position. To channel ESD voltages to ground, do not remove the wire from the ground lug.

The following warning applies to routers that use a DC power supply:



Warning

Before performing any of the following procedures, ensure that power is removed from the DC circuit. To ensure that all power is OFF, locate the circuit breaker on the panel board that services the DC circuit, switch the circuit breaker to the OFF position, and tape the switch handle of the circuit breaker in the OFF position. Statement 7



Warning

To avoid electric shock, do not insert a WAN or voice interface card into a 2-slot module while power is on or network cables are connected. Statement 68

Step 2

Remove all network cables, including telephone cables, from the router.



Caution

To prevent damage to the interface card, turn off electrical power and disconnect network cables from the chassis before inserting an interface card into an installed network module or router slot.

- Step 3** Using a number 1 Phillips or flat-blade screwdriver, loosen the screws on the blank interface card faceplate. (See Figure 27.) Remove the blank faceplate.

Figure 27 Blank Interface Card Faceplate

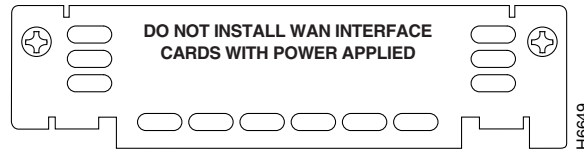

Tip Save blank interface card faceplates for future use.

- Step 4** Align the interface card with the guides in the slot on the network module and slide it gently into place until the edge connector is seated into the connector on the module. (See Figure 28.)

Figure 28 Installing an Interface Card in a Network Module (Typical)

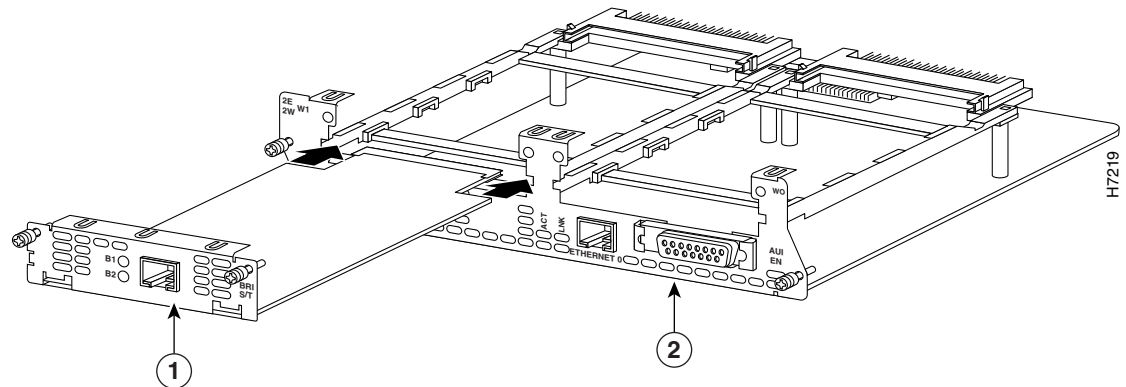

1	Interface card	2	2-slot network module
----------	----------------	----------	-----------------------

- Step 5** Using a number 1 Phillips or flat-blade screwdriver, tighten the captive mounting screws into the holes on the network module faceplate.

- Step 6** Reinstall the network interface cables and power up the router.

The following warning applies to routers that use a DC power supply:



Warning

After wiring the DC power supply, remove the tape from the circuit breaker switch handle and reinstate power by moving the handle of the circuit breaker to the ON position. Statement 8

Removing or Replacing Cisco Interface Cards for Cisco Access Routers



Caution

WAN interface cards and voice interface cards are not interchangeable. To prevent damage to the card, confirm that you are installing the correct type of interface card for the slot or network module you intend to use.

To remove or replace an interface card from a Cisco access router, perform these steps:

Step 1

Turn off electrical power to the router. Leave the power cable plugged in to channel ESD voltages to ground.

(For the Cisco MWR 1941-DC router) Turn off power by turning the DC power source circuit breaker to OFF. Tape the circuit breaker in the OFF position. To channel ESD voltages to ground, do not remove the wire from the ground lug.



Warning

Before performing any of the following procedures, ensure that power is removed from the DC circuit. To ensure that all power is OFF, locate the circuit breaker on the panel board that services the DC circuit, switch the circuit breaker to the OFF position, and tape the switch handle of the circuit breaker in the OFF position. Statement 7

Step 2

Remove all network cables, including telephone cables, from the router.



Caution

To prevent damage to the interface card, turn off electrical power and disconnect network cables from the chassis before inserting an interface card into an installed network module or router slot.



Timesaver

To make reconnection of network interface cables easier, label the cables or prepare a network cabling diagram before removing network interface cables from the network module.

Step 3

Using a number 1 Phillips or flat-blade screwdriver, loosen the captive mounting screws on the interface card faceplate.

Step 4

Using the faceplate edges, pull the interface card from the router slot.



Tip

Use the thumbscrews to pull the interface card faceplate away from the router chassis until you can grip the faceplate with your fingers.



Caution

Do not touch the interface card board. Handle the interface card by the edges of the faceplate to reduce the risk of damage to the card.

Step 5

Take one of the following actions:

- If you are replacing the interface card, use the procedures described in the “Installing Cisco Interface Cards in Cisco Access Routers” section on page 5.

**Caution**

Do not connect cables to an interface card until you have installed it.

- If you are not replacing the interface card, install a blank faceplates over the empty slots to ensure proper airflow. (See the “Installing Blank Faceplates” section on page 7.)

**Tip**

See the “Where to Go Next” section on page 27 for information on locating additional hardware documentation.

**Warning**

After wiring the DC power supply, remove the tape from the circuit breaker switch handle and reinstate power by moving the handle of the circuit breaker to the ON position. Statement 8

Installing Cisco Interface Cards on the Cisco ICS 7750

This section describes how to install Cisco interface cards on the Cisco Integrated Communication System (ICS) 7750, and contains the following subsections:

- Preparing to Install Interface Cards on the Cisco ICS 7750, page 21
- Installing Interface Cards on the Cisco ICS 7750, page 22

Cisco interface cards are installed in the Cisco ICS 7750 through either the multiservice route processor (MRP) or analog station interface 81 (ASI 81) cards. For more information about these cards, see the “Processor Cards Feature Summary” chapter in the *Cisco ICS 7750 System Description* document.

The MRP has two interface card slots (slot 0, slot 1) and the ASI 81 has one interface card slot (slot 1).

Preparing to Install Interface Cards on the Cisco ICS 7750

Before installing an interface card into the MRP or ASI 81, perform the following tasks:

- Verify that the MRP or ASI 81 card has the minimum Cisco IOS release required to support your interface card.
- Determine whether additional voice traffic due to installed voice or voice/WAN interface cards will require additional digital signal processors (DSPs). If additional DSPs are required, install up to two additional packet voice data modules (PVDMs) on each MRP or ASI 81 card to provide more processing power.

**Timesaver**

To configure digital voice ports correctly, any additional PVDMs must be installed before the interface card is installed on the MRP or ASI 81 card, or the Cisco ICS 7750 will not be recognized as a voice port.

**Tip**

To see a list of voice ports on the Cisco ICS 7750, use the Cisco IOS **show running-config** or **show diag** commands.

Installing Interface Cards on the Cisco ICS 7750

To install an interface card on an MRP or ASI 81 card for installation into the Cisco ICS 7750, perform the following steps:

- Step 1** If the MRP or ASI 81 is already installed in the chassis, back up the card configuration using the ICS System Manager application. For more information on backing up card configurations, refer to the ICS System Manager online help system.

If the MRP or ASI 81 is not installed in the chassis, go to Step 7.



Caution

Do not power down the chassis using the power supply switch or by unplugging the power supply. Doing so may cause the Cisco ICS 7750 to lose important configuration data and interrupts any applications or functions running on other cards in the chassis.



Timesaver

You do not have to turn off power to the Cisco ICS 7750 for this procedure. If the Cisco ICS 7750 is running, do not power down the entire chassis by using the chassis power supply switch or by unplugging the power supply.

- Step 2** Shut down operations on the MRP or ASI 81 card by pressing the SHTDN button on the card faceplate. The status LED on the card blinks; after several minutes, the status LED goes off. Wait for the status LED to go off before continuing to Step 3.

- Step 3** Put on an ESD-preventive wrist strap and attach the wrist strap to an unpainted chassis surface to establish a ground.



Caution

To prevent ESD damage, handle the cards only by the edges, and use an ESD-preventive wrist strap or other grounding device.

- Step 4** Disconnect any cables attached to the front of the interface card and secure them out of the way, using cable ties if necessary.

- Step 5** Loosen the lock-down screws at the top and bottom of the MRP or ASI 81 card.

- Step 6** Press the upper and lower extractor levers away from the chassis at the same time, disengaging the MRP or ASI 81 card from the Cisco ICS 7750 backplane. Pull the card away from the backplane about 1 inch (2.5 cm) to disengage it from the backplane. Do not completely remove the card from the chassis.



Caution

Always use the extractor levers to disengage or seat cards. Failure to use the levers can cause erroneous system error messages indicating a card failure.



Caution

Do not use the extractor levers to lift or support the weight of the cards.



Caution

Devices on system cards can get hot during operation. To remove a card, hold the card by the faceplate and bottom edge. Allow the card to cool before touching any other part of it or placing it in an antistatic bag.

- Step 7** If you are replacing an interface card, or if there is a blank interface card faceplate already installed in the MRP or ASI 81 card, use either a number 2 Phillips screwdriver or a small flat-blade screwdriver to remove the interface card or blank faceplate.



Tip Save the blank faceplate for future use.



Note If you remove an interface card while the MRP or ASI 81 is running, the interface card configuration is lost until the system card reboots.

- Step 8** Align the new interface card with the guides in the ASI 81 or MRP slot, and slide it gently into the slot. (See Figure 29.)

Figure 29 Installing Interface Cards into an MRP Card

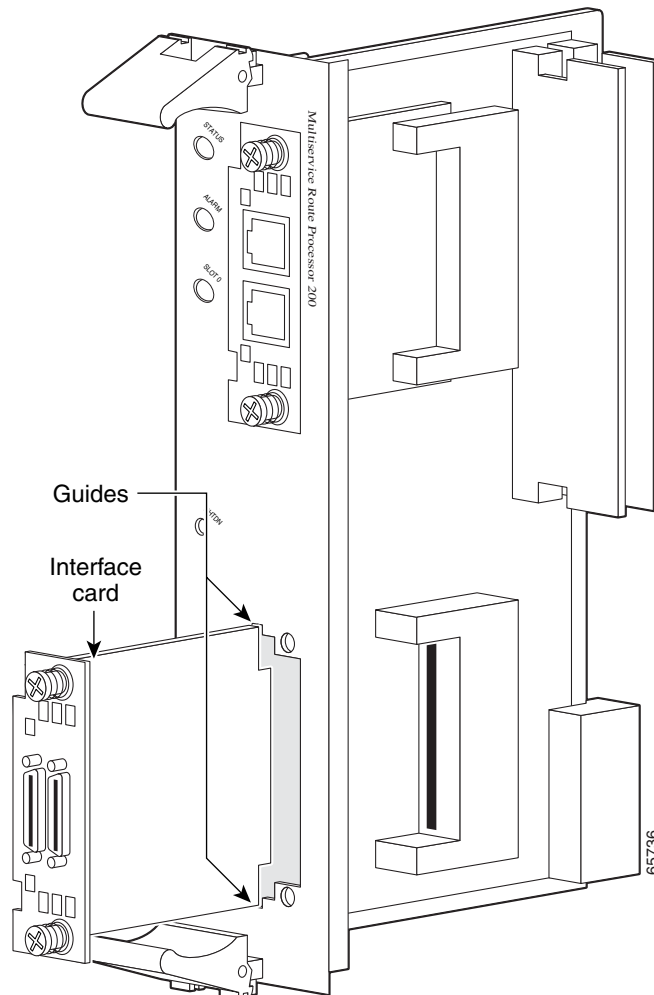

- Step 9** Push the interface card into place until you feel its edge connector seat securely into the connector on the MRP or ASI 81.
- Step 10** Using a Phillips or flat-blade screwdriver, tighten the interface card mounting screws until the interface card faceplate makes contact with the faceplate on the MRP or ASI 81 card.



Tip If an interface card slot on the ASI 81 or MRP is unoccupied, install a filler panel to enable proper airflow.

- Step 11** Align the ASI 81 or MRP with the upper and lower card guides in the chassis slot, and make sure that the extractor levers are in the open position (pointing outward).
- Step 12** With the top and bottom edges of the ASI 81 or MRP in the card guides, gently slide the card into the chassis until you feel resistance. Because there are grounding clips near the front and rear of the card guides, you might need to increase the amount of force that you use to get the card past the grounding clips. If you encounter extreme resistance, pull the card out slightly, and push it back in again.
- Step 13** Press the upper and lower extractor levers inward at the same time until they lock into their slots. This step firmly seats the ASI 81 or MRP into the chassis.
- Step 14** Connect cables to the ASI 81 or MRP interfaces.
- Step 15** The status LED on the ASI 81 or MRP blinks green as it boots. Wait until the LED is steady green, and then verify that the interface card installation. See the “Verifying Installation of Interface Cards in the Cisco ICS 7750” section on page 24.

Verifying Installation of Interface Cards in the Cisco ICS 7750

To verify that an interface card was installed successfully, check the system card LEDs using Table 7.

Table 7 LEDs Used to Verify Interface Card Installation on the Cisco ICS 7750

LED	Description
Status	Shows the status of the MRP or ASI 81: <ul style="list-style-type: none"> Blinks green while the card is booting up. Green after the power-on self-test (POST) is complete, and the card is operating correctly.
Slot 0 Slot 1	Shows the slot status of an MRP card that has an interface card installed in the slot, or of an 8-port FXS card in the ASI 81: <ul style="list-style-type: none"> Green shows that the WIC, VWIC, or VIC is correctly installed in the slot. Off indicates that no card is installed in the slot, or that a card is incorrectly installed in the slot.

Installing Other Accessories in Cisco Interface Cards

Certain Cisco interface cards support a variety of additional modules, such as small form-factor pluggable modules (SFPs).

Installing and Removing SFPs

SFPs are hot-swappable Ethernet interfaces that can be installed directly into Cisco interface cards. The following Cisco interface cards currently support SFPs:

- HWIC-1GE-SFP

This section describes a generic installation and removal procedure. SFPs use various latch designs (see Figure 31) to secure the module in the SFP port.



Note

Latch designs are not linked to SFP model or technology type; for information on the SFP technology type and model, see the label on the side of the SFP.

To install an SFP in a Cisco interface card, perform the following steps:

Step 1

Install the interface card in the router. (See the “Installing Cisco Interface Cards in Cisco Access Routers” section on page 5.)



Warning

Because invisible laser radiation may be emitted from the aperture of the port when no fiber cable is connected, avoid exposure to laser radiation and do not stare into open apertures. Statement 125

Step 2

Slide the SFP into the housing on the interface card until it is locked into position. (See Figure 30.) The SFP is designed to prevent improper insertion.



Tip

If the SFP uses a bale-clasp latch (see Figure 31), the bale-clasp handle should be on top of the SFP in the closed position for proper seating of the SFP module.

Figure 30 Installing an SFP in Cisco Interface Cards

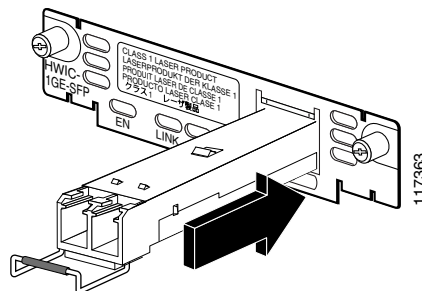

Caution

Do not remove the optical port plugs used on the SFP (gray color in the illustration) until you are ready to connect cabling to the interface card.

Step 3 (For optical SFPs) Remove the plugs from the SC connectors on the SFP.

Step 4 Connect the interface card to the network.



Timesaver

If installing the SFP in an uninstalled interface card, install the interface card (see Chapter , “Installing Cisco Interface Cards in Cisco Access Routers”) before connecting the interface card to the network.

To remove a SFP from an interface card, perform the following steps:

Step 1 Disconnect all cables from the SFP.



Warning

Because invisible laser radiation may be emitted from the aperture of the port when no fiber cable is connected, avoid exposure to laser radiation and do not stare into open apertures. Statement 125



Caution

The latching mechanism used on many SFPs locks the SFP into place whenever cables are connected. Do not pull on the cabling in an attempt to remove the SFP.

Step 2 Disconnect the SFP latch. (See Figure 31.)

Figure 31 Disconnecting SFP Latch Mechanisms

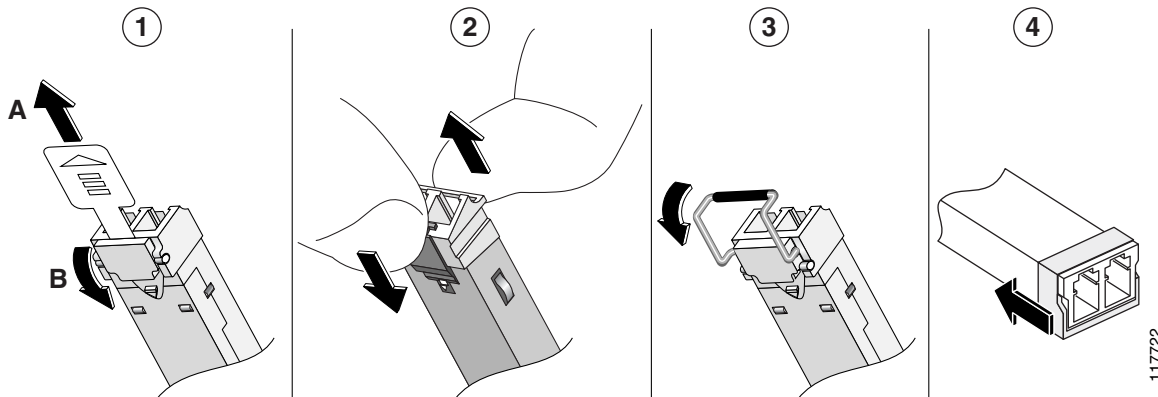

1	Sliding latch	2	Swing and slide latch
3	Bale-clasp latch	4	Plastic collar latch



Tip

Use a pen, screwdriver, or other small straight tool to gently release the bale-clasp handle if you cannot reach it with your fingers.

Step 3 Grasp the SFP on both sides and remove it from the interface card.

Where to Go Next

For an introduction to Cisco interface cards, go to *Cisco Interface Cards for Cisco Access Routers*.

For regulatory compliance and safety information, see the *Cisco Network Modules and Interface Cards Regulatory Compliance and Safety Information* document.

To locate hardware information about specific interface cards, go to the “Platform Support for Cisco Interface Cards” section in *Cisco Interface Cards for Cisco Access Routers*.

Obtaining Documentation, Obtaining Support, and Security Guidelines

For information on obtaining documentation, obtaining support, providing documentation feedback, security guidelines, and also recommended aliases and general Cisco documents, see the monthly *What's New in Cisco Product Documentation*, which also lists all new and revised Cisco technical documentation, at:

<http://www.cisco.com/en/US/docs/general/whatsnew/whatsnew.html>

CCVP, the Cisco logo, and Welcome to the Human Network are trademarks of Cisco Systems, Inc.; Changing the Way We Work, Live, Play, and Learn is a service mark of Cisco Systems, Inc.; and Access Registrar, Aironet, Catalyst, CCDA, CCDP, CCIE, CCIP, CCNA, CCNP, CCSP, Cisco, the Cisco Certified Internetwork Expert logo, Cisco IOS, Cisco Press, Cisco Systems, Cisco Systems Capital, the Cisco Systems logo, Cisco Unity, Enterprise/Solver, EtherChannel, EtherFast, EtherSwitch, Fast Step, Follow Me Browsing, FormShare, GigaDrive, HomeLink, Internet Quotient, IOS, iPhone, IP/TV, iQ Expertise, the iQ logo, iQ Net Readiness Scorecard, iQuick Study, LightStream, Linksys, MeetingPlace, MGX, Networkers, Networking Academy, Network Registrar, PIX, ProConnect, ScriptShare, SMARTnet, StackWise, The Fastest Way to Increase Your Internet Quotient, and TransPath are registered trademarks of Cisco Systems, Inc. and/or its affiliates in the United States and certain other countries.

All other trademarks mentioned in this document or Website are the property of their respective owners. The use of the word partner does not imply a partnership relationship between Cisco and any other company. (0711R)

Any Internet Protocol (IP) addresses used in this document are not intended to be actual addresses. Any examples, command display output, and figures included in the document are shown for illustrative purposes only. Any use of actual IP addresses in illustrative content is unintentional and coincidental.

© 2007 Cisco Systems, Inc. All rights reserved.



Serial Interface Cards

Revised: 6/7/07, OL-12843-01

Overview

This document describes Cisco serial interface cards and how to connect Cisco serial interface cards to a network. It contains the following sections:

- Serial WAN Interface Cards, page 1
- Serial High Speed WICs, page 6
- Related Documentation, page 12
- Obtaining Documentation, Obtaining Support, and Security Guidelines, page 13

For an overview of Cisco interface cards used for Cisco access routers see the *Cisco Interface Cards for Cisco Access Routers* document.

Serial WAN Interface Cards

This section describes serial WAN interface cards (WICs) and how to connect 1- and 2-port Cisco serial WICs to a network. It contains the following subsections:

- 1- and 2-Port Serial WICs, page 2
- 2-Port Asynchronous/Synchronous Serial WIC, page 2
- Serial WAN Interface Card LEDs, page 3
- Supported Platforms, page 3
- Prerequisites for Connecting 1- and 2-Port Serial WICs to a Network, page 3
- Connecting 1- and 2-Port Serial WICs to a Network, page 5

1- and 2-Port Serial WICs

The 1-port serial WIC (WIC-1T), shown in Figure 32, and the 2-port serial WIC (WIC-2T), shown in Figure 33, provide an EIA/TIA-232, EIA/TIA-449, V.35, X.21, data terminal equipment/data communications equipment (DTE/DCE), EIA-530 DTE, or nonreturn to zero/nonreturn to zero inverted (NRZ/NRZI) serial interface to a Cisco modular router.

Figure 32 1-Port Serial WIC Front Panel (WIC-1T)

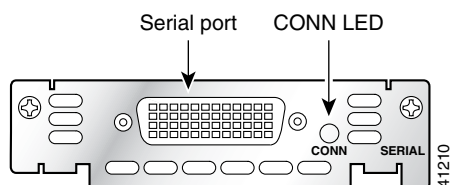
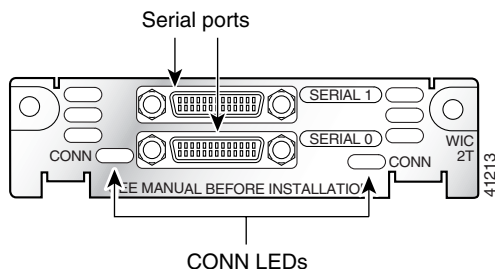

Figure 33 2-Port Serial WIC Front Panel (WIC-2T)



2-Port Asynchronous/Synchronous Serial WIC

The 2-port asynchronous/synchronous (A/S) WIC (WIC-2A/S), shown in Figure 34, provides an EIA/TIA-232, EIA/TIA-449, V.35, X.21, DTE/DCE, EIA-530, or EIA-530A serial interface to a Cisco modular router.



Caution

To comply with the Telcordia GR-1089 NEBS standard for electromagnetic compatibility and safety, connect the 2-port A/S WAN interface card (WIC-2A/S) only to intra-building or non-exposed wiring or cabling. The intrabuilding cable must be shielded and the shield must be grounded at both ends.

Figure 34 2-Port A/S Serial WIC Front Panel (WIC-2A/S)

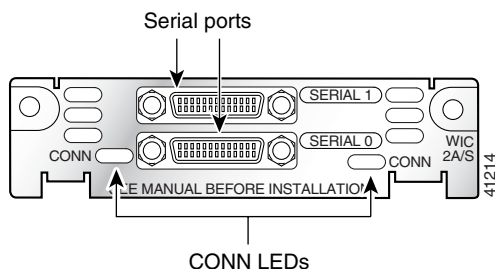

Serial WAN Interface Card LEDs

Each serial WIC has one LED, labeled CONN for each port, which lights when the serial port is connected. When the port is in DTE mode, the CONN LED indicates that Data Send Ready (DSR), Data Carrier Detect (DCD), and Clear To Send (CTS) have been detected. When the port is in DCE mode, it indicates that Data Terminal Ready (DTR) and Ready To Send (RTS) have been detected.

Supported Platforms

For a list of the platforms supported by a Cisco interface card refer to *Platform Support for Cisco Interface Cards*.

**Note**

In Cisco 3600 series and Cisco 2600 series routers, the 2-port serial WIC supports both asynchronous (up to 115.2 kbps) and synchronous (up to 2.048 Mbps) data rates. The 1-port serial WIC supports only synchronous data rates up to 2.048 Mbps.

**Note**

In the Cisco 1720 series router, the 1-port and 2-port serial WICs support both asynchronous (up to 115.2 kbps) and synchronous (up to 2.048 Mbps) data rates.

**Note**

In Cisco 1600 series routers, the 1-port serial WIC supports asynchronous data rates up to 115.2 kbps, and synchronous data rates up to 2.048 Mbps. The 2-port serial WIC is not supported on this router.

**Note**

In Cisco 3700 series, Cisco 3600 series, Cisco 2600 series, Cisco 1720, and Cisco MWR 1941-DC routers, the 2-port A/S WIC supports both asynchronous (up to 115.2 kbps) and synchronous (up to 128 kbps) data rates.

**Note**

The 2-port A/S WIC is not supported in Cisco 1600 series routers.

Finding Support Information for Platforms and Cisco IOS Software Images

Use Cisco Feature Navigator to find information about platform support and Cisco IOS software image support. Access Cisco Feature Navigator at <http://www.cisco.com/go/fn>. You must have an account on Cisco.com. If you do not have an account or have forgotten your username or password, click **Cancel** at the login dialog box and follow the instructions that appear.

Prerequisites for Connecting 1- and 2-Port Serial WICs to a Network

Before connecting a WIC to the network, ensure that the WIC is installed in the router, the equipment is properly grounded, and you have the proper cables for connecting the WIC to the network. This section describes the preparation necessary before connecting a 1- and 2-Port WIC to the network.

Installing a Cisco Serial WAN Interface Card

Install the Cisco serial wan interface card according to the instructions in *Installing Cisco Interface Cards in Cisco Access Routers*.

Grounding

Ensure that the equipment you are working with is properly grounded according to the instruction in *Installing Cisco Interface Cards in Cisco Access Routers*.

Cables

After you install the serial WIC, use the appropriate serial cable to connect the WIC's serial port to one of the following types of equipment. (See Figure 36.):

- An asynchronous modem, if connecting to an analog telephone line
- A synchronous modem, DSU or CSU, or other DCE, if connecting to a digital WAN line

The 1-port serial WIC has a DB-60 serial port, whereas the 2-port serial WIC and the 2-port A/S WIC have Cisco smart serial ports. Use the correct cable for your serial WIC.

The serial cable attached to a smart serial port determines the port's electrical interface type and mode (DTE or DCE).



Tip

A cable providing surge protection (CAB-SS-SURGE) is also available from Cisco Systems. See the "For connection limitations, see the "1- and 2-Port Serial WICs" section on page 2, and the "2-Port Asynchronous/Synchronous Serial WIC" section on page 2." section on page 5 for instructions on connecting the surge protector cable.

Types of Cables for 1- and 2-Port Serial WICs

Six types of serial cables (also called *serial adapter cables* or *serial transition cables*) are available from Cisco Systems for 1- and 2-port serial WICs:

- EIA/TIA-232 serial cable assembly
- EIA/TIA-449 serial cable assembly
- V.35 serial cable assembly
- X.21 serial cable assembly
- EIA/TIA-530 serial cable assembly
- EIA/TIA-530A serial cable assembly

All serial cables provide a universal plug at the interface card end. The network end of each cable provides the physical connectors most commonly used for the interface. For example, the network end of the EIA/TIA-232 serial cable is a DB-25 connector, the most widely used EIA/TIA-232 connector.

All serial interface types except EIA-530 are available in DTE or DCE format: DTE with a plug connector at the network end and DCE with a receptacle at the network end. V.35 is available in either mode with either gender at the network end. EIA-530 is available in DTE only.

Connecting 1- and 2-Port Serial WICs to a Network



Note

For connection limitations, see the “1- and 2-Port Serial WICs” section on page 2, and the “2-Port Asynchronous/Synchronous Serial WIC” section on page 2.

To connect the serial card to the WAN, follow these steps:

Step 1

Confirm that the router is turned off.

On the Cisco MWR 1941-DC router, turn off power by turning OFF the DC power source at the circuit breaker and taping the circuit breaker into the OFF position.



Caution

To comply with the Telcordia GR-1089 NEBS standard for electromagnetic compatibility and safety, connect the 2-port A/S WAN interface card (WIC-2A/S) only to intra-building or non-exposed wiring or cabling. The intrabuilding cable must be shielded and the shield must be grounded at both ends.

Step 2

(Optional) Connect the surge protection cable to the connector on the card faceplate. (See Figure 35.)

Step 3

(Optional) Connect one end of the appropriate serial cable to the other connector on the surge protector cable. (See Figure 35.)

Figure 35 Connecting the Cisco Surge Protector Cable (CAB-SS-SURGE) to a Serial WAN Interface

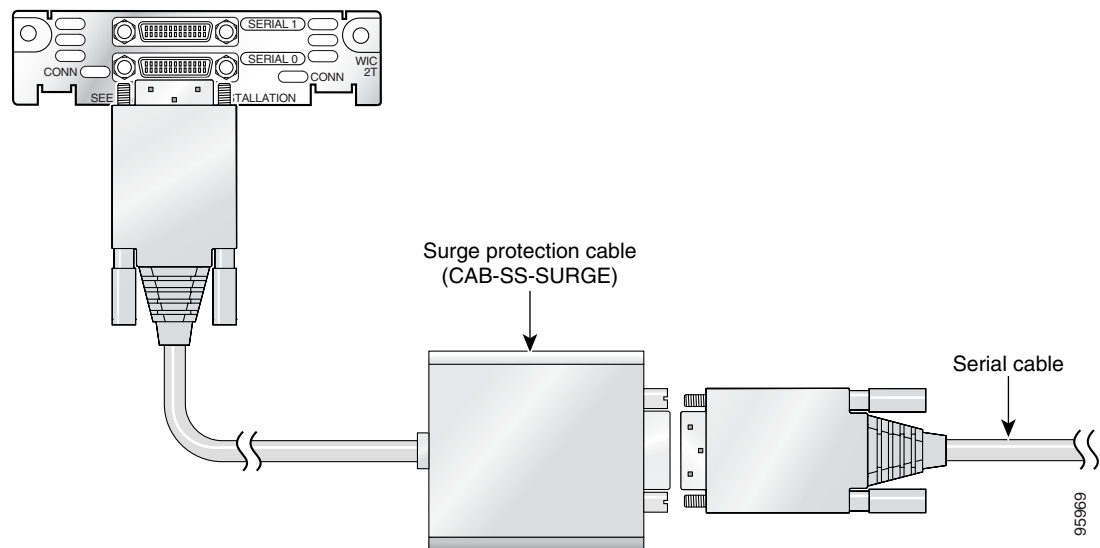

Step 4

Connect one end of the appropriate serial cable to the connector on the card faceplate.

Step 5

Connect the other end of the cable to the appropriate type of equipment, as shown in Figure 36.

Figure 36 Connecting the Serial WAN Port to a Modem or DSU/CSU

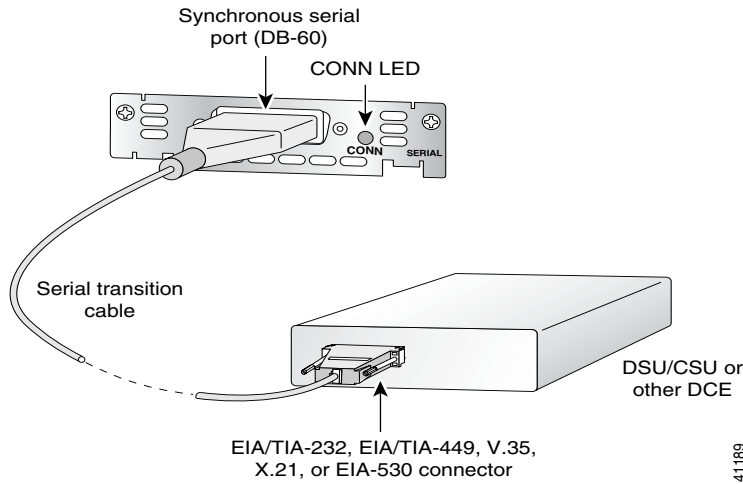

- Step 6** Turn on power to the router by pressing the power switch to the ON (|) position.
On the Cisco MWR 1941-DC router, turn on power to the router by turning ON the DC power source at the circuit breaker.
- Step 7** Check that the CONN LED goes on, which indicates that the card's serial port detects the WAN serial connection.

Serial High Speed WICs

There are five Cisco serial high speed WICs (HWICs). This section describes the HWICs and tells how to connect them to a network. It contains the following subsections:

- 4-Port Multiprotocol High Speed HWIC, page 6
- 4-Port Multiprotocol Low Speed Asynchronous/Synchronous HWIC, page 7
- 8-Port RS-232 Asynchronous/Synchronous HWIC, page 8
- 8-Port Asynchronous HWIC, page 8
- 16-Port Asynchronous HWIC, page 8
- LED Status, page 9
- Supported Platforms, page 9
- Prerequisites for Connecting Serial HWICs to the Network, page 9
- Connecting Serial HWICs to the Network, page 12

4-Port Multiprotocol High Speed HWIC

The 4-port multiprotocol high speed HWIC (HWIC-4T) is illustrated in Figure 37. Protocols supported are Async (SLIP), Async (PPP), HDLC, Bisync, and transparent.

Interfaces supported are as follows:

- In both DTE and DCE formats: V35, X21, RS-232, and RS-449
- In DTE format only: EIA-530 and EIA-530A

The maximum data rate supported is 8 Mbps per port.



Caution

To comply with the Telcordia GR-1089 NEBS standard for electromagnetic compatibility and safety, connect the 4-port multiprotocol high speed HWIC (HWIC-4T) only to intra-building or non-exposed wiring or cabling. The intrabuilding cable must be shielded and the shield must be grounded at both ends.

Figure 37 4-Port Multiprotocol HWIC Front Panel (HWIC-4T)

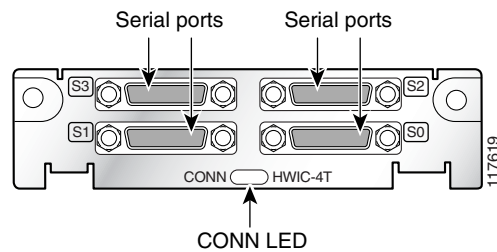

4-Port Multiprotocol Low Speed Asynchronous/Synchronous HWIC

The 4-port multiprotocol low speed asynchronous/synchronous HWIC (HWIC-4A/S) is illustrated in Figure 38. Protocols supported are Async (SLIP), Async (PPP), HDLC, Bisync, and transparent.

Interfaces supported are as follows:

- In both DTE and DCE formats: V35, X21, RS-232, and RS-449
- In DTE format only: EIA-530 and EIA-530A

The maximum data rate supported is 256 kbps per port (synchronous).



Caution

To comply with the Telcordia GR-1089 NEBS standard for electromagnetic compatibility and safety, connect the 4-port multiprotocol low speed asynchronous/synchronous HWIC (HWIC-4A/S) only to intra-building or non-exposed wiring or cabling. The intrabuilding cable must be shielded and the shield must be grounded at both ends.

Figure 38 4-Port Multiprotocol A/S HWIC Front Panel (HWIC-4A/S)

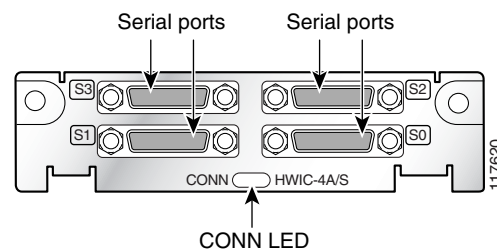

8-Port RS-232 Asynchronous/Synchronous HWIC

The 8-port RS-232 asynchronous/synchronous HWIC (HWIC-8A-RS232), illustrated in Figure 39, provides 8 asynchronous/synchronous RS-232 interfaces in both DCE and DTE formats. Data rates of up to 230.4 kbps are supported in asynchronous mode, and up to 256 kbps in synchronous mode.

Figure 39 8-Port RS-232 Asynchronous/Synchronous HWIC Front Panel (HWIC-8A/S-RS232)

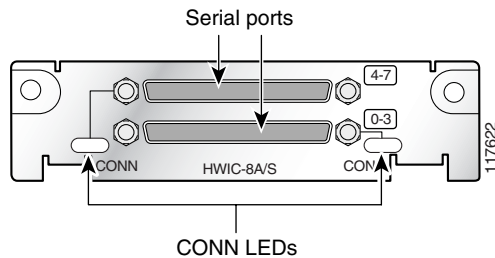

8-Port Asynchronous HWIC

The 8-port asynchronous HWIC (HWIC-8A), illustrated in Figure 40, provides 8 asynchronous RS-232 interfaces in DTE format, at data rates of up to 230.4 kbps.



Caution

To comply with the Telcordia GR-1089 NEBS standard for electromagnetic compatibility and safety, connect the 8-port asynchronous HWIC (HWIC-8A) only to intra-building or non-exposed wiring or cabling. The intrabuilding cable must be shielded and the shield must be grounded at both ends.

Figure 40 8-Port Asynchronous HWIC Front Panel (HWIC-8A)

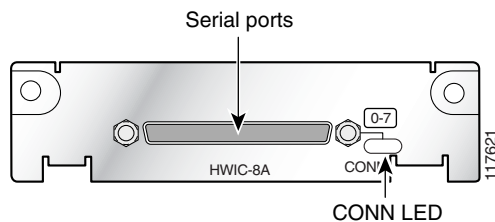

16-Port Asynchronous HWIC

The 16-port asynchronous HWIC (HWIC-16A), illustrated in Figure 41, provides 16 asynchronous RS-232 interfaces in DTE format, at data rates of up to 230.4 kbps.



Caution

To comply with the Telcordia GR-1089 NEBS standard for electromagnetic compatibility and safety, connect the 16-port asynchronous HWIC (HWIC-16A) only to intra-building or non-exposed wiring or cabling. The intrabuilding cable must be shielded and the shield must be grounded at both ends.

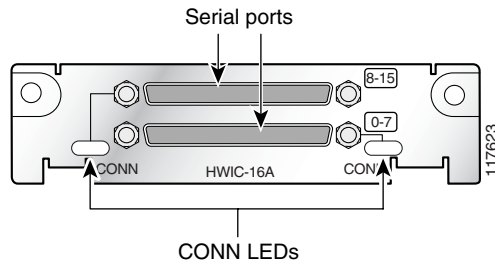
Figure 41 16-Port Asynchronous HWIC Front Panel (HWIC-16A)

LED Status

Due to the high port density on the HWIC front panels, the amount of LED status per port is limited. There is no room for individual LEDs to indicate transmit or receive activity, or clock status.

HWIC-4T and HWIC-4A/S have a single bi-color LED to monitor status over four ports. HWIC-8A has a single LED to monitor status over 8 ports. There are two LEDs on the HWIC-8A/S-RS232 that monitor 4 ports each. On the HWIC-16A, two LEDs monitor 8 ports each.

See Table 8 for the definition of HWIC LED Status.

Table 8 HWIC LED Status

LED Status	Definition
Solid Green	Monitored ports are active (have initialized without error).
Solid Yellow	At least one monitored port is in loopback mode.
Off	Monitored ports are not active or have failed to initialize.

Supported Platforms

For a list of the platforms supported by a Cisco interface card refer to *Platform Support for Cisco Interface Cards*.

Finding Support Information for Platforms and Cisco IOS Software Images

Use Cisco Feature Navigator to find information about platform support and Cisco IOS software image support. Access Cisco Feature Navigator at <http://www.cisco.com/go/fn>. You must have an account on Cisco.com. If you do not have an account or have forgotten your username or password, click **Cancel** at the login dialog box and follow the instructions that appear.

Prerequisites for Connecting Serial HWICs to the Network

Before connecting a serial high speed WIC (HWIC) to the network, ensure that the HWIC is installed in the router, the equipment is properly grounded, and you have the proper cables for connecting the HWIC to the network. This section describes the preparation necessary before connecting a Cisco serial HWIC to the network.

Installing a Cisco Serial High Speed WAN Interface Card

Install the Cisco serial HWIC according to the instructions in *Installing Cisco Interface Cards in Cisco Access Routers*.

Grounding

Ensure that the equipment you are working with is properly grounded.

For instructions on grounding your HWIC, refer to *Installing Cisco Interface Cards in Cisco Access Routers*.

Cables

After you install the serial HWIC, use the appropriate serial cable to connect the HWIC ports to the following types of equipment:

- Asynchronous modems, if connecting to analog telephone lines
- Synchronous modems, data service units/channel service units (DSUs/CSUs), or other DCEs, if connecting to digital WAN lines

The 4-port serial HWICs have 26-pin 12-in-1 Cisco smart serial ports, whereas the 8- and 16-port serial HWICs have 68-pin serial ports. Use the correct cable for your serial HWIC.

Cables for 4-Port Serial HWICs

The 4-port serial HWICs use Cisco smart serial cables. Six types of smart serial cables are available:

- EIA/TIA-232 serial cable assembly
- EIA/TIA-449 serial cable assembly
- V.35 serial cable assembly
- X.21 serial cable assembly
- EIA-530 serial cable assembly
- EIA-530A serial cable assembly

All of these serial cables provide a 26-pin plug at the interface card end. The network end of each cable provides the physical connectors most commonly used for the interface. For example, the network end of the EIA/TIA-232 serial cable is a DB-25 connector, the most widely used EIA/TIA-232 connector.

Refer to the *Cisco Modular Access Router Cable Specifications* for network end connectors and pinouts of these cables.

The EIA-530 and EIA-530A serial cables are available in DTE format only. All other cables are available in either DTE or DCE format.

Cables for 8-Port and 16-Port Serial HWICs

The following cables are available from Cisco Systems for the 8-port and 16-port serial HWICs.

Cable for the 8-Port RS-232 Asynchronous/Synchronous HWIC

The 8-port RS-232 asynchronous/synchronous HWIC uses a quad cable, consisting of a 68-pin connector on the interface card end and four DB25 connectors on the system end. (See Figure 42.) This cable is available in either DCE or DTE format.

Figure 42 Quad Serial Cable

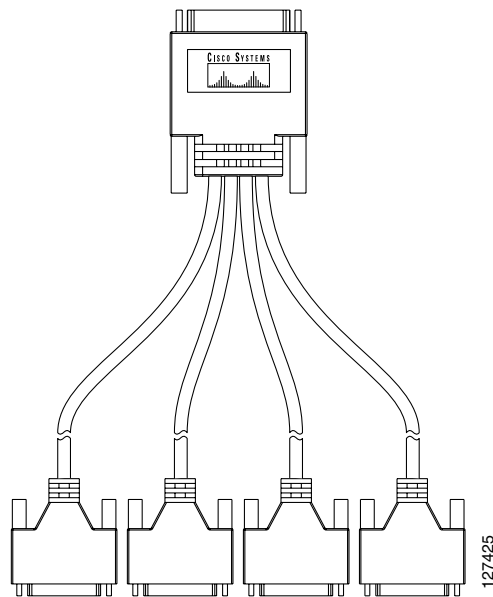

Cable for the 8-Port and 16-Port Asynchronous HWICs

The 8-port and 16-port asynchronous HWICs use an octal cable, consisting of a 68-pin connector on the interface card end and eight RJ45 connectors on the system end. See Figure 43. This cable is available in DTE format only.

Figure 43 Octal Serial Cable

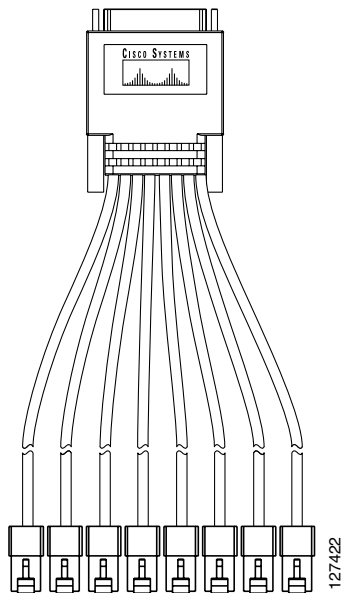

Connecting Serial HWICs to the Network

To connect the serial HWIC to the network, follow these steps:

-
- Step 1** Confirm that the router is turned off.
 - Step 2** Connect one end of the appropriate serial cable to the connector on the card faceplate.
 - Step 3** Connect the other end (or ends) of the cable to the appropriate type of equipment.
 - Step 4** Turn on power to the router.
 - Step 5** Check that the CONN LED goes on, which indicates that the card's serial port detects a WAN serial connection.
-

Related Documentation

Related documentation is available on Cisco.com or on the Product Documentation DVD. For more information, see the “Obtaining Documentation, Obtaining Support, and Security Guidelines” section on page 13.

- *2-Port Async/Sync WAN Interface Card (WIC-2A/S)*, tech note
- *Understanding the 1-Port Serial WAN Interface Card (WIC-1T)*, tech note

- *Understanding 2-Port Serial WAN Interface Card (WIC-2T)*, tech note
- *Cisco Network Modules and Interface Cards Regulatory Compliance and Safety Information*
- “Configuring Asynchronous Connections” chapter of the *Cisco 1700 Series Router Software Configuration Guide*
- “Configuring Serial Interfaces” chapter of the *Cisco IOS Interface Configuration Guide* for your Cisco IOS software release
- *Cisco Signaling Link Terminal G.732 Support*, Cisco IOS Release 12.2(2)T feature module
- *Cisco Signaling Link Terminal*, Cisco IOS Release 12.1(1)T feature module
- *Multilink PPP Across Two Serial Physical-layer Async Interfaces*, sample configuration
- *Configuring PPP Dialin with External Modems*, sample configuration
- *Configuring Basic MPLS Using IS-IS*, sample configuration
- *Inverse MUX Application using Multilink PPP*, sample configuration
- *Configuring a Basic MPLS VPN*, sample configuration
- *Multilink Via Virtual-Template on Two Serial Interfaces*, sample configuration

Obtaining Documentation, Obtaining Support, and Security Guidelines

For information on obtaining documentation, obtaining support, providing documentation feedback, security guidelines, and also recommended aliases and general Cisco documents, see the monthly *What's New in Cisco Product Documentation*, which also lists all new and revised Cisco technical documentation, at:

<http://www.cisco.com/en/US/docs/general/whatsnew/whatsnew.html>

CCVP, the Cisco logo, and Welcome to the Human Network are trademarks of Cisco Systems, Inc.; Changing the Way We Work, Live, Play, and Learn is a service mark of Cisco Systems, Inc.; and Access Registrar, Aironet, Catalyst, CCDA, CCDP, CCIE, CCIP, CCNA, CCNP, CCSP, Cisco, the Cisco Certified Internetwork Expert logo, Cisco IOS, Cisco Press, Cisco Systems, Cisco Systems Capital, the Cisco Systems logo, Cisco Unity, Enterprise/Solver, EtherChannel, EtherFast, EtherSwitch, Fast Step, Follow Me Browsing, FormShare, GigaDrive, HomeLink, Internet Quotient, IOS, iPhone, IP/TV, iQ Expertise, the iQ logo, iQ Net Readiness Scorecard, iQuick Study, LightStream, Linksys, MeetingPlace, MGX, Networkers, Networking Academy, Network Registrar, PIX, ProConnect, ScriptShare, SMARTnet, StackWise, The Fastest Way to Increase Your Internet Quotient, and TransPath are registered trademarks of Cisco Systems, Inc. and/or its affiliates in the United States and certain other countries.

All other trademarks mentioned in this document or Website are the property of their respective owners. The use of the word partner does not imply a partnership relationship between Cisco and any other company. (0711R)

Any Internet Protocol (IP) addresses used in this document are not intended to be actual addresses. Any examples, command display output, and figures included in the document are shown for illustrative purposes only. Any use of actual IP addresses in illustrative content is unintentional and coincidental.

© 2007 Cisco Systems, Inc. All rights reserved.



ISDN BRI WAN Interface Cards

Revised: 6/7/07, OL-12844-01

Overview

This document describes ISDN BRI WAN interface cards (WICs) and how to connect ISDN BRI WICs to a network. It contains the following sections:

- ISDN BRI S/T WAN Interface Cards, page 1
- ISDN BRI U WAN Interface Cards, page 5
- ISDN BRI S/T Leased-Line WAN Interface Card, page 9
- Supported Platforms, page 12
- Related Documentation, page 12
- Obtaining Documentation, Obtaining Support, and Security Guidelines, page 13

ISDN BRI S/T WAN Interface Cards

This section describes ISDN BRI S/T WICs and how to connect ISDN BRI S/T WICs to a network and contains the following sub sections:

- ISDN BRI S/T WICs Overview
- ISDN BRI S/T WIC LEDs
- Prerequisites for Connecting an ISDN BRI S/T WIC to a Network
- Connecting an ISDN BRI S/T WIC to a Network

ISDN BRI S/T WICs Overview

The ISDN BRI S/T WICs connect to an ISDN network through an external NT1 device. This interface is also known as an *S/T interface*. There are three ISDN BRI S/T WICs:



Note

You can distinguish between WIC36 and WIC models of an ISDN BRI WIC by the location and labeling of the LEDs and by the number and location of cutouts in the faceplate.

- 1-port ISDN BRI WIC with S/T interface (WIC36-1B-S/T) (see Figure 44)
- 1-port ISDN BRI WIC with S/T interface (WIC-1B-S/T) (see Figure 45)
- 1-port ISDN BRI WIC with S/T interface, version 3 (WIC-1B-S/T-V3) (see Figure 46)



Caution

To comply with the Telcordia GR-1089 NEBS standard for electromagnetic compatibility and safety, connect the 1-port ISDN BRI WIC with S/T interface, version 3 (WIC-1B-S/T-V3) only to intra-building or non-exposed wiring or cabling. The intrabuilding cable must be shielded and the shield must be grounded at both ends.

Figure 44 WIC36-1B-S/T Front Panel

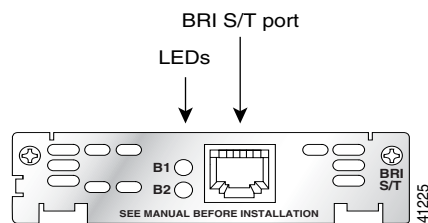

Figure 45 WIC-1B-S/T Front Panel

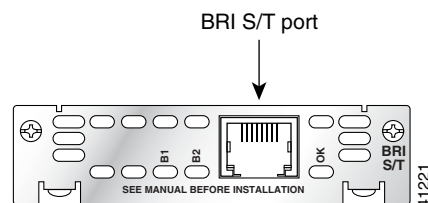
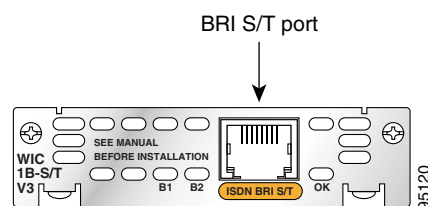

Figure 46 WIC-1B-S/T-V3 Front Panel



ISDN BRI S/T WIC LEDs

The ISDN BRI S/T WIC LEDs are shown in Figure 44, Figure 45, and Figure 46. The functions of the LEDs are described in Table 9.

Table 9 ISDN BRI S/T WIC LEDs

LED	Description
B1	ISDN connection on B1 channel when blinking.
B2	ISDN connection on B2 channel when blinking.
OK	ISDN port has established a connection with the central office switch (D channel).

Prerequisites for Connecting an ISDN BRI S/T WIC to a Network

Before connecting a WIC to the network, ensure that the WIC is installed in the router, the equipment is properly grounded, and you have the proper cables for connecting the WIC to the network. This section describes the preparation necessary before connecting an ISDN BRI S/T WIC to the network.

Installing a Cisco ISDN BRI S/T WAN Interface Card

Install the Cisco WIC according to the instructions in *Installing Cisco Interface Cards in Cisco Access Routers*.



Note

Older WIC36-1B-S/T, WIC36-1B-U, CPAWIC36-1B-S/T, or CPAWIC36-1B-U interface cards mount only in the W1 slot of a 2-slot network module and provide a single BRI interface. Newer WIC-1B-S/T or WIC-1B-U interface cards can mount in either slot of a 2-slot network module. For more information on BRI network modules, see the *Cisco Network Modules Hardware Installation Guide*.

Grounding

Ensure that the equipment you are working with is properly grounded. For instructions on grounding your WIC, refer to *Installing Cisco Interface Cards in Cisco Access Routers*.

Cables

Use a straight-through RJ-48C-to-RJ-48C BRI cable (not included) to connect an ISDN BRI S/T WIC to a network.

Setting Jumpers on ISDN BRI WICs

The WIC-1B-S/T, WIC-1B-S/T-V3, and WIC-1B-U interface cards do not have termination jumpers.



Note

For long-distance point-to-point configuration, and for the last station in point-to-multipoint configuration, use an external 100-ohm terminator.

The WIC36-1B-S/T, WIC36-1B-U, CPAWIC36-1B-S/T, and CPAWIC36-1B-U interface cards have two termination jumpers, labeled J1 and J2. Before installing a WIC36-1B-S/T, WIC36-1B-U, CPAWIC36-1B-S/T, or CPAWIC36-1B-U interface card, ensure that the termination jumpers are set appropriately for your installation.

The jumpers are factory-configured in the B position. Keep the jumpers in this position to use the ISDN BRI WIC in a point-to-point connection or as the last device on the line of a passive-bus connection. Set the termination jumpers to the A position to use the ISDN BRI WIC in a passive-bus connection in which it is not the last device on the line. The jumpers are shown in Figure 47.

Figure 47 Jumper Locations on the Older ISDN BRI WIC

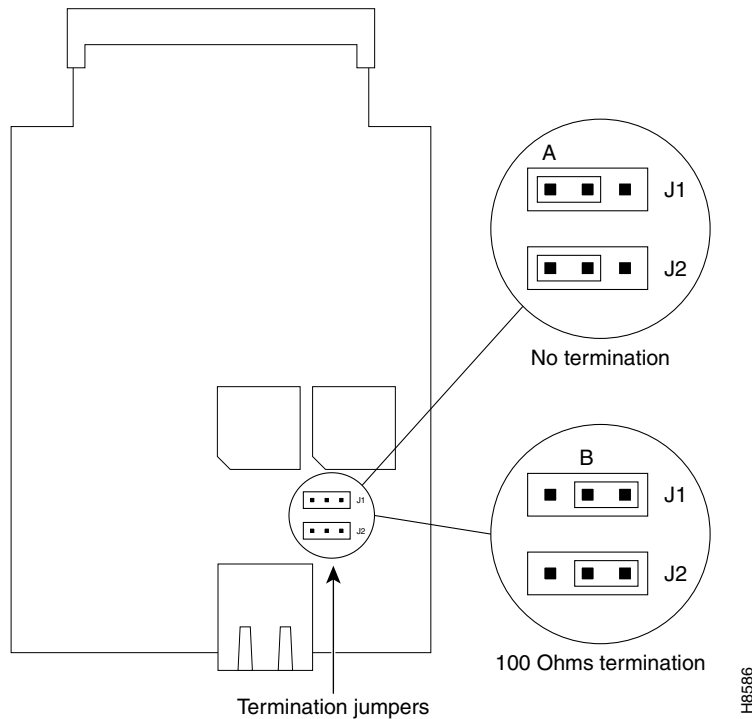

Connecting an ISDN BRI S/T WIC to a Network



Hazardous network voltages are present in WAN ports regardless of whether power to the unit is OFF or ON. To avoid electric shock, use caution when working near WAN ports. When detaching cables, detach the end away from the unit first. Statement 1026



The ISDN connection is regarded as a source of voltage that should be inaccessible to user contact. Do not attempt to tamper with or open any public telephone operator (PTO)-provided equipment or connection hardware. Any hardwired connection (other than by a nonremovable, connect-one-time-only plug) must be made only by PTO staff or suitably trained engineers.

Statement 23

To connect an ISDN BRI S/T WIC to a network, follow these steps:

Step 1 Confirm that the router is turned off.



Caution

To comply with the Telcordia GR-1089 NEBS standard for electromagnetic compatibility and safety, connect the 1-port ISDN BRI WIC with S/T interface, version 3 (WIC-1B-S/T-V3) only to intra-building or non-exposed wiring or cabling. The intrabuilding cable must be shielded and the shield must be grounded at both ends.

Step 2 Connect one end of a straight-through RJ-48C-to-RJ-48C cable to the RJ-48C port on the ISDN BRI S/T WIC.

Step 3 Connect the other end of the cable to the NT1 device, as shown in Figure 48.

Figure 48 Connecting an ISDN BRI S/T WIC to an NT1 Device

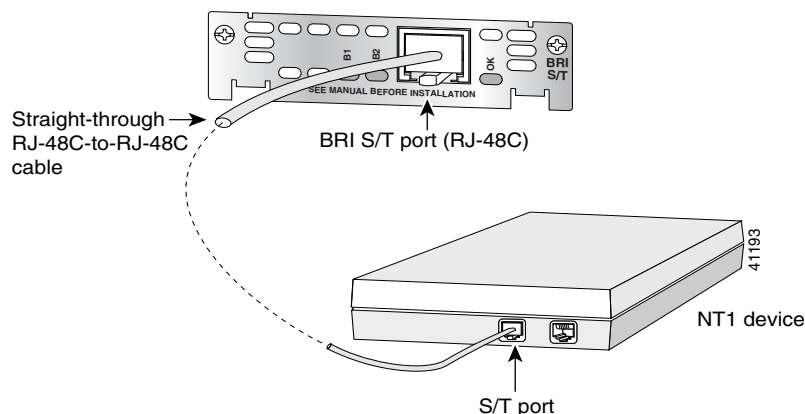

Step 4 Connect the NT1 device to the ISDN wall jack according to the documentation that came with the NT1 device.

Step 5 Turn on power to the router.

Step 6 Check that the OK LED goes on, which indicates that the ISDN port has established a connection with the central office switch.

ISDN BRI U WAN Interface Cards

This section describes how to connect ISDN BRI U WICs to a network and contains the following sections:

- ISDN BRI U WICs Overview
- ISDN BRI U WIC LEDs
- Prerequisites for Connecting an ISDN BRI U WIC to a Network
- Connecting an ISDN BRI U WIC to a Network

ISDN BRI U WICs Overview

The 1-port ISDN BRI U WICs contain an integrated NT1 device. This interface is also known as a *U interface*. There are three ISDN BRI U WICs:



Note

You can distinguish between WIC36 and WIC models of an ISDN BRI WIC by the location and labeling of the LEDs and by the number and location of cutouts in the faceplate.

- 1-port ISDN BRI WIC with integrated NT1 device (WIC36-1B-U) (see Figure 49)
- 1-port ISDN BRI WIC with integrated NT1 device (WIC-1B-U) (see Figure 50)
- 1-port ISDN BRI WIC with integrated NT1 device, version 2 (WIC-1B-U-V2) (see Figure 51)

Figure 49 *WIC36-1B-U Front Panel*

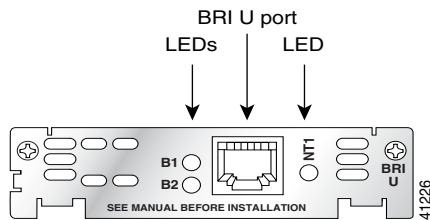

Figure 50 *WIC-1B-U Front Panel*

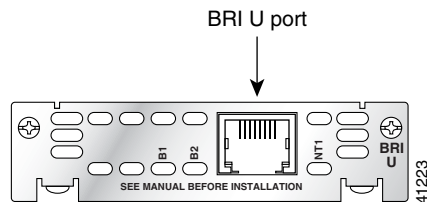
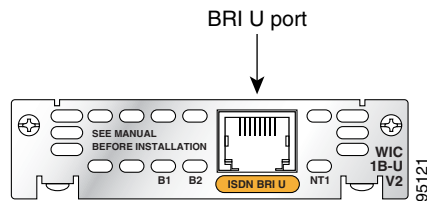

Figure 51 *WIC-1B-U-V2 Front Panel*



ISDN BRI U WIC LEDs

The ISDN BRI U WIC LEDs are shown in Figure 49, Figure 50, and Figure 51. The functions of the LEDs are described in Table 10.

Table 10 ISDN BRI U WIC LEDs

LED	Description
B1	ISDN connection on B1 channel when blinking.
B2	ISDN connection on B2 channel when blinking.
OK	ISDN port has established a connection with the central office switch (D channel).

Prerequisites for Connecting an ISDN BRI U WIC to a Network

Before connecting a WIC to the network, ensure that the WIC is installed in the router, the equipment is properly grounded, and you have the proper cables for connecting the WIC to the network. This section describes the preparation necessary before connecting an ISDN BRI U WIC to the network.

Installing a Cisco ISDN BRI S/T WAN Interface Card

Install the Cisco WIC according to the instructions in *Installing Cisco Interface Cards in Cisco Access Routers*.



Note

Older WIC36-1B-S/T, WIC36-1B-U, CPAWIC36-1B-S/T, or CPAWIC36-1B-U interface cards mount only in the W1 slot of a 2-slot network module and provide a single BRI interface. Newer WIC-1B-S/T or WIC-1B-U interface cards can mount in either slot of a 2-slot network module. For more information on BRI network modules, see the *Cisco Network Modules Hardware Installation Guide*.

Grounding

For instructions on grounding your WIC, refer to *Installing Cisco Interface Cards in Cisco Access Routers*.

Cables

Use a straight-through RJ-48C-to-RJ-48C BRI cable (not included) to connect an ISDN BRI U WIC to a network.

Setting Jumpers on ISDN BRI WICs

The WIC-1B-S/T and WIC-1B-U interface cards do not have termination jumpers. The WIC36-1B-S/T, WIC36-1B-U, CPAWIC36-1B-S/T, and CPAWIC36-1B-U interface cards have two termination jumpers, labeled J1 and J2. Before installing a WIC36-1B-S/T, WIC36-1B-U, CPAWIC36-1B-S/T, or CPAWIC36-1B-U interface card, ensure that the termination jumpers are set appropriately for your installation.

The jumpers are factory-configured in the B position. Keep the jumpers in this position to use the ISDN BRI WIC in a point-to-point connection or as the last device on the line of a passive-bus connection. Set the termination jumpers to the A position to use the ISDN BRI WIC in a passive-bus connection in which it is not the last device on the line. The jumpers are shown in Figure 52.

Figure 52 Jumper Locations on the Older ISDN BRI WIC

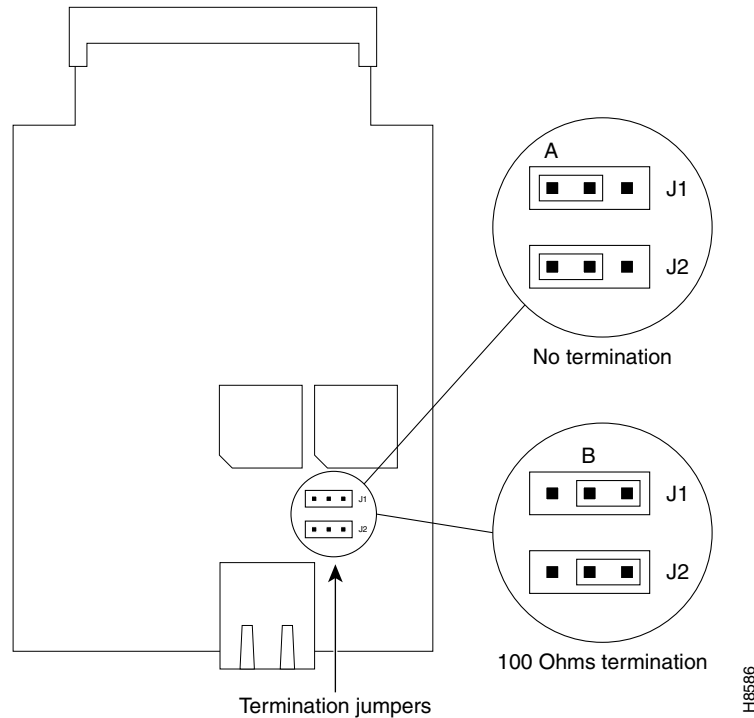

Connecting an ISDN BRI U WIC to a Network



Warning

Hazardous network voltages are present in WAN ports regardless of whether power to the unit is OFF or ON. To avoid electric shock, use caution when working near WAN ports. When detaching cables, detach the end away from the unit first. Statement 1026



Warning

The ISDN connection is regarded as a source of voltage that should be inaccessible to user contact. Do not attempt to tamper with or open any public telephone operator (PTO)-provided equipment or connection hardware. Any hardwired connection (other than by a nonremovable, connect-one-time-only plug) must be made only by PTO staff or suitably trained engineers.

Statement 23

To connect an ISDN BRI U WIC to a network, follow these steps:

Step 1 Confirm that the router is turned off.



Warning

To comply with the Telcordia GR-1089 NEBS standard for electromagnetic compatibility and safety, connect the 1-port ISDN BRI WIC with U interface, version 2 (WIC-1B-U-V2) only to intra-building or unexposed wiring or cable. The intra-building port(s) of the equipment or subassembly must not be metallically connected to interfaces that connect to the OSP or its wiring. These interfaces are designed for use as intra-building interfaces only (Type 2 or Type 4 ports as described in GR-1089-CORE, Issue 4) and require isolation from the exposed OSP cabling. The addition of Primary Protectors is not sufficient protection in order to connect these interfaces metallically to OSP wiring.

Step 2 Connect one end of a straight-through RJ-48C-to-RJ-48C cable to the RJ-48C port on the ISDN BRI U WIC.

Step 3 Connect the other end of the cable directly to the ISDN wall jack as shown in Figure 53.

Figure 53 Connecting an ISDN BRI U WIC to an ISDN Wall Jack

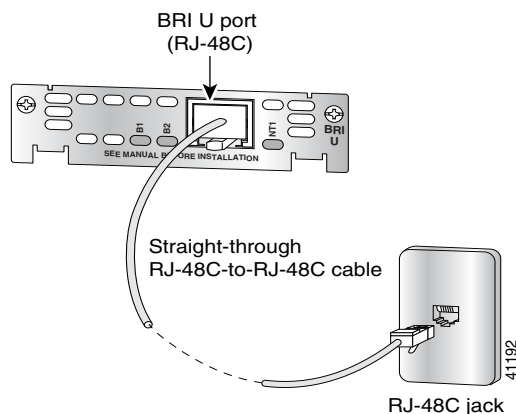

Step 4 Turn on power to the router.

Step 5 Check that the OK LED goes on, which indicates that the ISDN port has established a connection with the central office switch.

ISDN BRI S/T Leased-Line WAN Interface Card

This section describes how to connect ISDN BRI S/T leased-line WICs to a network and contains the following sections:

- ISDN BRI S/T Leased-Line WICs Overview
- ISDN BRI S/T Leased-Line WIC LEDs
- Prerequisites for Connecting an ISDN BRI S/T Leased-Line WIC to a Network
- Connecting an ISDN BRI S/T Leased-Line WIC to a Network

ISDN BRI S/T Leased-Line WICs Overview

The 1-port ISDN BRI S/T leased-line WIC (WIC-1B-S/T-LL) provides a single B channel operating in leased-line mode at 64-kbps. (See Figure 54.)

Figure 54 WIC-1B-S/T-LL Front Panel

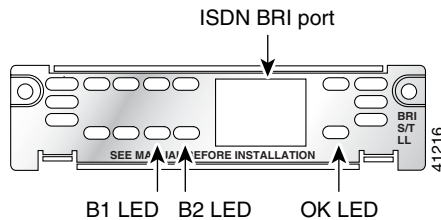

ISDN BRI S/T Leased-Line WIC LEDs

The ISDN BRI S/T leased-line WIC LEDs are shown in Figure 54. The functions of the LEDs are described in Table 11.

Table 11 ISDN BRI S/T Leased-Line WIC LEDs

LED	Description
B1	ISDN connection on B1 channel when blinking.
B2 ¹	ISDN connection on B2 channel (not used).
OK	ISDN port has established a connection with the central office switch (D channel).

1. Always off for 64 kbps, which is available on B1 only.

Prerequisites for Connecting an ISDN BRI S/T Leased-Line WIC to a Network

Before connecting a WIC to the network, ensure that the WIC is installed in the router, the equipment is properly grounded, and you have the proper cables for connecting the WIC to the network. This section describes the preparation necessary before connecting an ISDN BRI U WIC to the network.

Installing a Cisco ISDN BRI S/T WAN Interface Card

Install the Cisco WIC according to the instructions in *Installing Cisco Interface Cards in Cisco Access Routers*.

Grounding

Ensure that the equipment you are working with is properly grounded. For instructions on grounding your WIC, refer to *Installing Cisco Interface Cards in Cisco Access Routers*.

Cables

Use a straight-through RJ-48C-to-RJ-48C BRI cable (not included) to connect an ISDN BRI S/T leased-line WIC to a network.

Connecting an ISDN BRI S/T Leased-Line WIC to a Network

Warning

Hazardous network voltages are present in WAN ports regardless of whether power to the unit is OFF or ON. To avoid electric shock, use caution when working near WAN ports. When detaching cables, detach the end away from the unit first. Statement 1026

Warning

The ISDN connection is regarded as a source of voltage that should be inaccessible to user contact. Do not attempt to tamper with or open any public telephone operator (PTO)-provided equipment or connection hardware. Any hardwired connection (other than by a nonremovable, connect-one-time-only plug) must be made only by PTO staff or suitably trained engineers. Statement 23

To connect an ISDN BRI S/T leased-line WIC to a network, follow these steps:

- Step 1** Confirm that the router is turned off.
- Step 2** Connect one end of the straight-through RJ-48C cable to the RJ-48C port on the ISDN BRI S/T leased-line WIC.
- Step 3** Connect the other end of the cable to the NT1 device, as shown in Figure 55.

Figure 55 Connecting the ISDN BRI S/T Leased Line Card to an NT1 Device

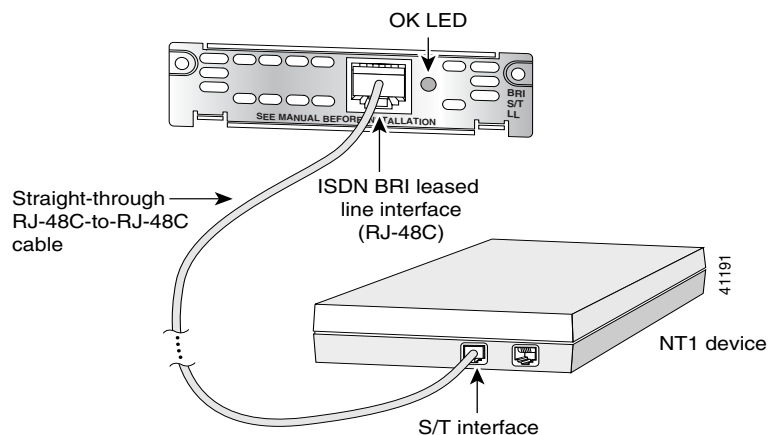

- Step 4** Connect the NT1 device to the ISDN wall jack according to the documentation that came with the NT1 device.
- Step 5** Turn on power to the router.

- Step 6** Check that the OK LED goes on, which indicates that the ISDN port has established a connection with the central office switch.
-

Supported Platforms

For a list of the platforms supported by a Cisco interface card refer to *Platform Support for Cisco Interface Cards*.

Finding Support Information for Platforms and Cisco IOS Software Images

Use Cisco Feature Navigator to find information about platform support and Cisco IOS software image support. Access Cisco Feature Navigator at <http://www.cisco.com/go/fn>. You must have an account on Cisco.com. If you do not have an account or have forgotten your username or password, click **Cancel** at the login dialog box and follow the instructions that appear.

Related Documentation

Related documentation is available on Cisco.com or on the Product Documentation DVD. For more information, see the “Obtaining Documentation, Obtaining Support, and Security Guidelines” section on page 13.

- *Cisco ISDN BRI S/T WIC for the Cisco 1700, 1800, 2600, 2800, 3600, 3700, and 3800 Series*, data sheet
- *Cisco Network Modules and Interface Cards Regulatory Compliance and Safety Information*
- “Configuring ISDN BRI” chapter of the *Cisco IOS Dial Technologies Configuration Guide* for your Cisco IOS software release
- *Configuring a Router to Dial Multiple Sites using ISDN BRI*, sample configuration

Obtaining Documentation, Obtaining Support, and Security Guidelines

For information on obtaining documentation, obtaining support, providing documentation feedback, security guidelines, and also recommended aliases and general Cisco documents, see the monthly *What's New in Cisco Product Documentation*, which also lists all new and revised Cisco technical documentation, at:

<http://www.cisco.com/en/US/docs/general/whatsnew/whatsnew.html>

CCVP, the Cisco logo, and Welcome to the Human Network are trademarks of Cisco Systems, Inc.; Changing the Way We Work, Live, Play, and Learn is a service mark of Cisco Systems, Inc.; and Access Registrar, Aironet, Catalyst, CCDA, CCDP, CCIE, CCIP, CCNA, CCNP, CCSP, Cisco, the Cisco Certified Internetwork Expert logo, Cisco IOS, Cisco Press, Cisco Systems, Cisco Systems Capital, the Cisco Systems logo, Cisco Unity, Enterprise/Solver, EtherChannel, EtherFast, EtherSwitch, Fast Step, Follow Me Browsing, FormShare, GigaDrive, HomeLink, Internet Quotient, IOS, iPhone, IP/TV, iQ Expertise, the iQ logo, iQ Net Readiness Scorecard, iQuick Study, LightStream, Linksys, MeetingPlace, MGX, Networkers, Networking Academy, Network Registrar, PIX, ProConnect, ScriptShare, SMARTnet, StackWise, The Fastest Way to Increase Your Internet Quotient, and TransPath are registered trademarks of Cisco Systems, Inc. and/or its affiliates in the United States and certain other countries.

All other trademarks mentioned in this document or Website are the property of their respective owners. The use of the word partner does not imply a partnership relationship between Cisco and any other company. (0711R)

Any Internet Protocol (IP) addresses used in this document are not intended to be actual addresses. Any examples, command display output, and figures included in the document are shown for illustrative purposes only. Any use of actual IP addresses in illustrative content is unintentional and coincidental.

© 2007 Cisco Systems, Inc. All rights reserved.



DSU/CSU WAN Interface Cards

Revised: 6/7/07, OL-12845-01

Overview

This chapter describes DSU/CSU WAN interface cards (WICs) and how to connect DSU/CSU (WICs) to a network and contains the following sections:

- 56/64-kbps DSU/CSU WAN Interface Card, page 1
- T1/FT1 DSU/CSU WAN Interface Card, page 3
- Supported Platforms, page 7
- Related Documentation, page 8
- Obtaining Documentation, Obtaining Support, and Security Guidelines, page 8

For an overview of Cisco interface cards used for Cisco access routers refer to *Cisco Interface Cards for Cisco Access Routers*.

56/64-kbps DSU/CSU WAN Interface Card

This section describes 56/64-kbps DSU/CSU WICs and how to connect 56/64-kbps DSU/CSU WICs to a network and contains the following sections:

- 56/64-kbps DSU/CSU WICs Overview
- 56/64-kbps DSU/CSU WIC LEDs
- Prerequisites for Connecting 56/64-kbps DSU/CSU WICs to a Network, page 2
- Connecting the 56/64-kbps DSU/CSU WIC to a Network

56/64-kbps DSU/CSU WICs Overview

The 1-port 56/64-kbps DSU/CSU WIC (WIC-1DSU-56K4) includes an integral DSU/CSU and can be configured to provide circuit-switched, dedicated, or leased-line service at 56 kbps. This WIC also supports 64-kbps dedicated lines. (See Figure 56.)

Figure 56 WIC-1DSU-56K4 Front Panel

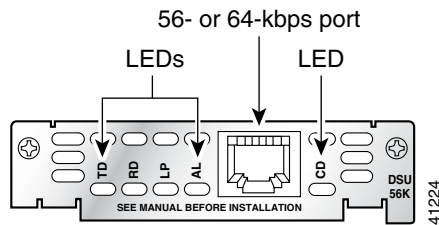

56/64-kbps DSU/CSU WIC LEDs

The 56/64-kbps DSU/CSU WIC LEDs, are shown in Figure 56. The functions of the LEDs are described in Table 12.

Table 12 56/64-kbps DSU/CSU WIC LEDs

LED	Description
TD	Data is being transmitted to the DTE interface.
RD	Data is being received from the DTE interface.
LP	Internal DSU/CSU is in loopback mode.
AL	One of these alarm conditions is present: no receive signal, loss of frame signal from the remote station, or out of service signal from the remote station. This LED is off during normal operation.
CD	Internal DSU/CSU in the WIC is communicating with another DSU/CSU.

Prerequisites for Connecting 56/64-kbps DSU/CSU WICs to a Network

Before connecting a WIC to the network, ensure that the WIC is installed in the router, the equipment is properly grounded, and you have the proper cables for connecting the WIC to the network. This section describes the preparation necessary before connecting a 56/64-kbps DSU/CSU WIC to the network.

Installing a Cisco Serial WAN Interface Card

Install the Cisco serial wan interface card according to the instructions in *Installing Cisco Interface Cards in Cisco Access Routers*.

Grounding

Ensure that the equipment you are working with is properly grounded. For instructions on grounding your serial WIC, refer to *Installing Cisco Interface Cards in Cisco Access Routers*.

Cables

Use a straight-through RJ-48S-to-RJ-48S cable (not included) to connect a 56/64-kbps DSU/CSU WIC to a network.

Connecting the 56/64-kbps DSU/CSU WIC to a Network

To connect a 56/64-kbps DSU/CSU WIC to a network, follow these steps:

-
- Step 1** Confirm that the router is turned off.
 - Step 2** Connect one end of the straight-through RJ-48S-to-RJ-48S cable to the RJ-48S port on the 56/64-kbps DSU/CSU WIC.
 - Step 3** Connect the other end of the cable to the 56/64-kbps services wall jack, as shown in Figure 57.

Figure 57 Connecting the 56/64-kbps DSU/CSU WIC to a 56/64-kbps Services Wall Jack

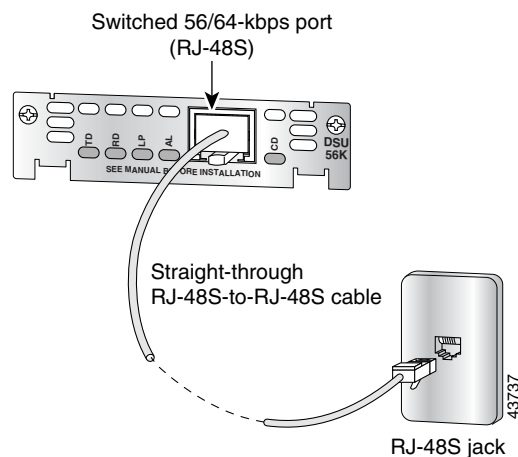

- Step 4** Turn on power to the router.
 - Step 5** Check that the CD LED comes on, which indicates that the internal DSU/CSU is communicating with the DSU/CSU at the 56/64-kbps service provider's central office.
-

T1/FT1 DSU/CSU WAN Interface Card

This section describes how to connect T1/fractionalized T1 (FT1) DSU/CSU WICs to the network and contains the following sections:

- T1/FT1 DSU/CSU WICs Overview
- T1/FT1 DSU/CSU WIC LEDs and Loopback Button
- Enabling Wetting Current on T1/FT1 DSU/CSU WICs
- Prerequisites for Connecting a T1/FT1 DSU/CSU WIC to a Network
- Connecting a T1/FT1 DSU/CSU WIC to a Network

T1/FT1 DSU/CSU WICs Overview

The 1-port T1/fractionalized T1 (FT1) DSU/CSU WIC includes an integrated data service unit/channel service unit (DSU/CSU). The WIC can be configured for either full T1 services or fractionalized T1 services. There are two T1/FT1 DSU/CSU WICs:

- 1-port T1/fractionalized T1 (FT1) DSU/CSU WIC (WIC-1DSU-T1) (see Figure 58)
- 1-port T1/fractionalized T1 (FT1) DSU/CSU WIC, version 2 (WIC-1DSU-T1-V2) (see Figure 59)



Caution

To comply with the Telcordia GR-1089 NEBS standard for electromagnetic compatibility and safety, connect the 1-port T1/FT1 DSU/CSU WIC, version 2 (WIC-1DSU-T1-V2) only to intra-building or non-exposed wiring or cabling. The intrabuilding cable must be shielded and the shield must be grounded at both ends.

Figure 58 WIC-1DSU-T1 Front Panel

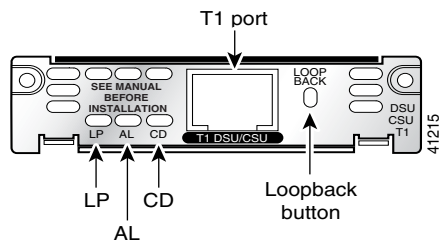
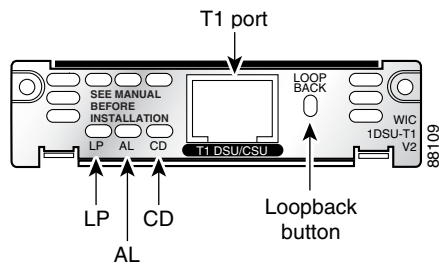

Figure 59 WIC-1DSU-T1-V2 Front Panel



T1/FT1 DSU/CSU WIC LEDs and Loopback Button

The T1/FT1 DSU/CSU WIC LEDs and loopback button are shown in Figure 58 and Figure 59. The functions of the LEDs and loopback button are described in Table 13.

Table 13 T1/FT1 DSU/CSU WIC LEDs and Loopback Button

Feature	Color	Description
LP LED	Yellow	Line or loopback state is detected or is manually set by the user.
	Off	Normal operation.

Table 13 *T1/FT1 DSU/CSU WIC LEDs and Loopback Button (continued)*

Feature	Color	Description
AL LED	Yellow	Remote station has an alarm condition.
	Off	Normal operation.
CD LED	Green	Internal DSU/CSU in the WIC is communicating with another DSU/CSU. This LED is on during normal operation.
Loopback button	—	Push this button to place the WIC into loopback mode. The service provider can send a signal to test the connection from your site to the central office switch. Push this button again to turn off loopback mode.

Enabling Wetting Current on T1/FT1 DSU/CSU WICs

The WIC-1DSU-T1-V2 interface card supports wetting current. Wetting current is a small amount of electrical current (60 to 140 milliamps) sent from the central office to the card to prevent the corrosion of electrical contacts in the card's network connection.

Wetting current may be enabled or disabled by the user. It is controlled by the placement of a jumper on connector J2 on the card. Figure 60 shows the J2 connector and the jumper.

The feature is enabled by connecting pins 1 and 2 of the J2 connector with a jumper. It is disabled either by removing the jumper or by connecting pins 2 and 3 of the J2 connector.

The card is shipped with the jumper connecting pins 2 and 3 on the J2 connector, which disables the wetting current.

Figure 60 Jumper Settings for Controlling Wetting Current on the WIC-1DSU-T1 V2 Card

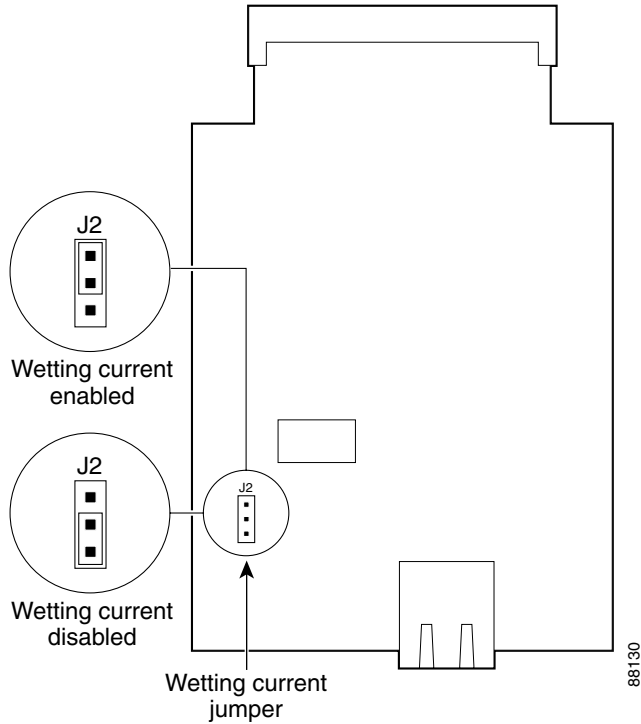

Prerequisites for Connecting a T1/FT1 DSU/CSU WIC to a Network

Before connecting a WIC to the network, ensure that the WIC is installed in the router, the equipment is properly grounded, and you have the proper cables for connecting the WIC to the network. This section describes the preparation necessary before connecting a T1/FT1 DSU/CSU WIC to the network.

Installing a Cisco Serial WAN Interface Card

Install the Cisco serial wan interface card according to the instructions in *Installing Cisco Interface Cards in Cisco Access Routers*.

Grounding

Ensure that the equipment you are working with is properly grounded. For instructions on grounding your serial WIC, refer to *Installing Cisco Interface Cards in Cisco Access Routers*.

Cables

Use a straight-through RJ-48C-to-RJ-48C cable to connect a T1/FT1 DSU/CSU WIC to a network.

Connecting a T1/FT1 DSU/CSU WIC to a Network

To connect a T1/FT1 DSU/CSU WIC to a network, follow these steps:

Step 1 Confirm that the router is turned off.



Caution

To comply with the Telcordia GR-1089 NEBS standard for electromagnetic compatibility and safety, connect the 1-port T1/FT1 DSU/CSU WIC, version 2 (WIC-1DSU-T1-V2) only to intra-building or non-exposed wiring or cabling. The intrabuilding cable must be shielded and the shield must be grounded at both ends.

Step 2 Connect one end of the straight-through RJ-48C-to-RJ-48C cable to the RJ-48C port on the T1/FT1 DSU/CSU WIC.

Step 3 Connect the other end of the cable to the T1 wall jack, as shown in Figure 61.

Figure 61 Connecting the T1/FT1 DSU/CSU WIC to a T1 Wall Jack

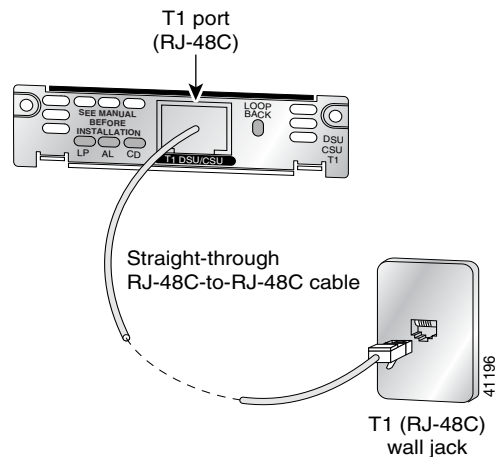

Step 4 Turn on power to the router.

Step 5 Check that the CD LED comes on, which means that the internal DSU/CSU is communicating with the DSU/CSU at the T1 service provider's central office.

Supported Platforms

For a list of the platforms supported by a Cisco interface card refer to *Platform Support for Cisco Interface Cards*.

Finding Support Information for Platforms and Cisco IOS Software Images

Use Cisco Feature Navigator to find information about platform support and Cisco IOS software image support. Access Cisco Feature Navigator at <http://www.cisco.com/go/fn>. You must have an account on Cisco.com. If you do not have an account or have forgotten your username or password, click **Cancel** at the login dialog box and follow the instructions that appear.

Related Documentation

Related documentation is available on Cisco.com or on the Product Documentation DVD. For more information, see the “Obtaining Documentation, Obtaining Support, and Security Guidelines” section on page 8.

- *Understanding the 1-Port 4-Wire 56/64 Kbps CSU/DSU WAN Interface Card (WIC-1DSU-56K4)*, tech note
- *Cisco Network Modules and Interface Cards Regulatory Compliance and Safety Information*
- *Configuring Cisco Integrated Data Service Unit/Channel Service Unit (DSU/CSU) Modules and WAN Interface Cards*, tech note
- “Configuring Serial Interfaces” chapter in the *Cisco IOS Interface Configuration Guide* for your Cisco IOS software release
- *56K CSU Support for the Cisco Signaling Link Terminal*, Cisco IOS Release 12.2(2)T feature module
- *Cisco Signaling Link Terminal*, Cisco IOS Release 12.1(1)T feature module
- *1-Port DSU/CSU T1 WIC for the Cisco 1700, Cisco 2600, Cisco 3600, and Cisco 3700 Series Routers*, Cisco IOS Release 12.2(15)ZL feature module

Obtaining Documentation, Obtaining Support, and Security Guidelines

For information on obtaining documentation, obtaining support, providing documentation feedback, security guidelines, and also recommended aliases and general Cisco documents, see the monthly *What's New in Cisco Product Documentation*, which also lists all new and revised Cisco technical documentation, at:

<http://www.cisco.com/en/US/docs/general/whatsnew/whatsnew.html>

CCVP, the Cisco logo, and Welcome to the Human Network are trademarks of Cisco Systems, Inc.; Changing the Way We Work, Live, Play, and Learn is a service mark of Cisco Systems, Inc.; and Access Registrar, Aironet, Catalyst, CCDA, CCDP, CCIE, CCIP, CCNA, CCNP, CCSP, Cisco, the Cisco Certified Internetwork Expert logo, Cisco IOS, Cisco Press, Cisco Systems, Cisco Systems Capital, the Cisco Systems logo, Cisco Unity, Enterprise/Solver, EtherChannel, EtherFast, EtherSwitch, Fast Step, Follow Me Browsing, FormShare, GigaDrive, HomeLink, Internet Quotient, IOS, iPhone, IP/TV, iQ Expertise, the iQ logo, iQ Net Readiness Scorecard, iQuick Study, LightStream, Linksys, MeetingPlace, MGX, Networkers, Networking Academy, Network Registrar, PIX, ProConnect, ScriptShare, SMARTnet, StackWise, The Fastest Way to Increase Your Internet Quotient, and TransPath are registered trademarks of Cisco Systems, Inc. and/or its affiliates in the United States and certain other countries.

All other trademarks mentioned in this document or Website are the property of their respective owners. The use of the word partner does not imply a partnership relationship between Cisco and any other company. (0711R)

Any Internet Protocol (IP) addresses used in this document are not intended to be actual addresses. Any examples, command display output, and figures included in the document are shown for illustrative purposes only. Any use of actual IP addresses in illustrative content is unintentional and coincidental.

© 2007 Cisco Systems, Inc. All rights reserved.



DSL Interface Cards

Revised: 6/7/07, OL-12846-01

Overview

This document describes Cisco digital subscriber line (DSL) interface cards and how to connect Cisco DSL interface cards to a network. It contains the following sections:

- ADSL WICs, page 1
- G.SHDSL WICs, page 3
- G.SHDSL High Speed WICs (HWICs), page 6
- ADSL High Speed WICs (HWICs), page 7
- Cables, page 9
- Connecting a DSL Interface Card to the Network, page 9
- Using POTS Splitters and Microfilters with an ADSL-over-POTS WIC (WIC-1ADSL), page 14
- Related Documentation, page 18
- Obtaining Documentation, Obtaining Support, and Security Guidelines, page 19

For an overview of Cisco interface cards used for Cisco access routers see the *Cisco Interface Cards for Cisco Access Routers* document.

ADSL WICs

The DSL wide area network (WAN) interface cards (WICs) support one DSL line between a single customer premises equipment (CPE) subscriber and a central office.

Asymmetric digital subscriber line (ADSL) WICs are available in three variations:

- ADSL over POTS (WIC-1ADSL)
- ADSL over POTS with Dying Gasp support (WIC-1ADSL-DG)
- ADSL over ISDN with Dying Gasp support (WIC-1ADSL-I-DG)

The ADSL over POTS interface card is commonly used to provide ADSL services over ordinary telephone lines. The ADSL-over-ISDN interface card is used to provide ADSL services in those areas of the world that have extensive ISDN backbones already in place.



Note

The term *dying gasp* refers to *power status* as defined in ITU-T standard G.991.2, section 7.1.2.5.3.

LEDs on ADSL WICs

ADSL WICs have three LEDs, which are shown in Figure 62 and are described in Table 14.

Figure 62 ADSL and G.SHDSL WIC Front Panels

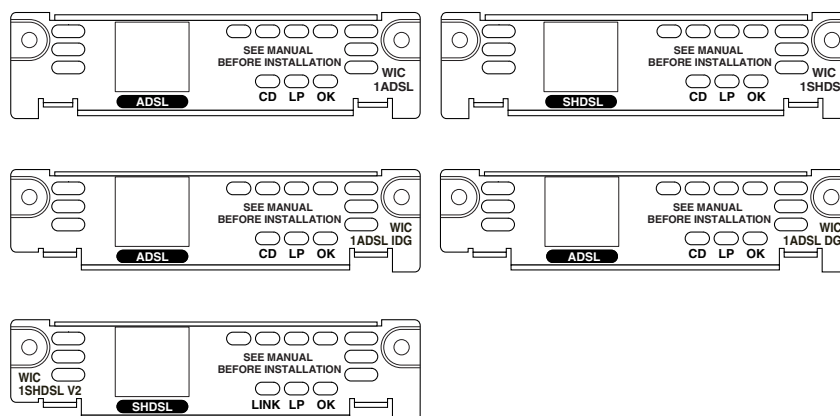

Table 14 ADSL WIC LEDs

LED	Color	Description
CD LED	Green	Lit when the unit is connected to the network and operating normally. On ADSL interface cards only, this LED blinks while training with DSLAMs. Does not apply to the WIC-1SHDSL-V2 or WIC-1SHDSL-V3 interface cards.
LP LED	Yellow	DSL interface is in loopback mode.
	Off	Normal operation.
OK LED	Green	Enabled when the card is detected by the router.
LINK (CD) LED	Green and Yellow	Green when cells or frames are passing between the host and the DSLAM. Yellow when the T1E1 framer detects an alarm. Applies only to the WIC-1SHDSL-V2 and WIC-1SHDSL-V3 interface cards.

Supported Platforms

For a list of the platforms supported by a Cisco interface card refer to *Platform Support for Cisco Interface Cards*.

Finding Support Information for Platforms and Cisco IOS Software Images

Use Cisco Feature Navigator to find information about platform support and Cisco IOS software image support. Access Cisco Feature Navigator at <http://www.cisco.com/go/fn>. You must have an account on Cisco.com. If you do not have an account or have forgotten your username or password, click **Cancel** at the login dialog box and follow the instructions that appear.

G.SHDSL WICs

The Multirate Symmetrical High-Speed Digital Subscriber Line (G.SHDSL) cards support two or more DSL lines.

The G.SHDSL WICs are available in the following variations:

- The WIC-1SHDSL is a 1-port interface card that supports one pair of copper wire (2-wire G.SHDSL). It is compatible with Cisco G.SHDSL line cards in the Cisco 6015, Cisco 6130, Cisco 6160, or Cisco 6260 digital subscriber line access multiplexer (DSLAM).
- The WIC-1SHDSL-V2 and WIC-1SHDSL-V3 interface cards are 1-port cards. They support all G.SHDSL features, and supply two twisted pairs of wires to implement 4-wire (two-line) G.SHDSL. These WICs support dying gasp and wetting current. They also provide a higher symmetrical bandwidth and longer reach than 2-wire G.SHDSL.



Caution

To comply with the Telcordia GR-1089 NEBS standard for electromagnetic compatibility and safety, connect the 1-port G.SHDSL interface card (WIC-1SHDSL-V2 and WIC-1SHDSL-V3) only to intra-building or non-exposed wiring or cabling. The intrabuilding cable must be shielded and the shield must be grounded at both ends.

LEDs on G.SHDSL WICs

The ADSL and G.SHDSL WICs have three LEDs, which are shown in Figure 63 and are described in Table 15.

Figure 63 G.SHDSL WIC Front Panels

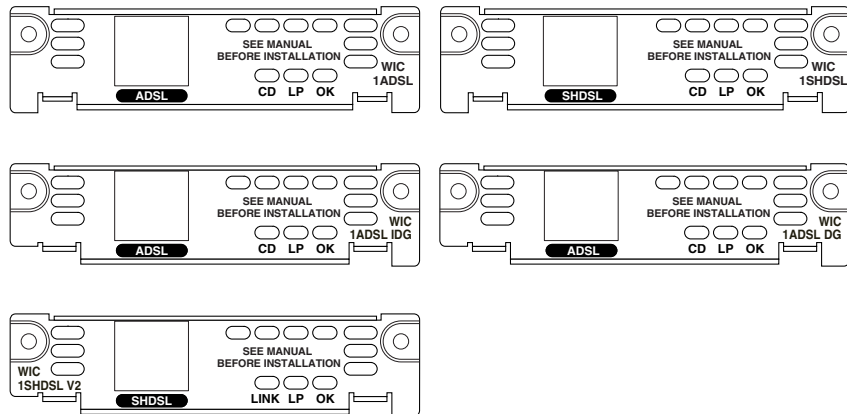

95231

Table 15 G.SHDSL WIC LEDs

LED	Color	Description
CD LED	Green	Lit when the unit is connected to the network and operating normally. On ADSL interface cards only, this LED blinks while training with DSLAMs. Does not apply to the WIC-1SHDSL-V2 or WIC-1SHDSL-V3 interface cards.
LP LED	Yellow	DSL interface is in loopback mode.
	Off	Normal operation.

Table 15 *G.SHDSL WIC LEDs (continued)*

LED	Color	Description
OK LED	Green	Enabled when the card is detected by the router.
LINK (CD) LED	Green and Yellow	Green when cells or frames are passing between the host and the DSLAM. Yellow when the T1E1 framer detects an alarm. Applies only to the WIC-1SHDSL-V2 and WIC-1SHDSL-V3 interface cards.

Supported Platforms

Table 16 lists the Cisco router platforms that are compatible with each mode available on the WIC-1SHDSL-V2 interface card.

Table 16 *Cisco router platforms compatible with WIC-1SHDSL-V2 interface card*

Mode	Cisco Platforms
2-wire ATM	<ul style="list-style-type: none"> • Cisco 1721 • Cisco 1751 • Cisco 1760 • Cisco 1841 • Cisco 26xxXM • Cisco 2691 • Cisco 28xx • Cisco 3631 • Cisco 37xx • Cisco 38xx
2-wire T1/E1 in back-to-back configurations	<ul style="list-style-type: none"> • Cisco 1721 • Cisco 1751 • Cisco 1760 • Cisco 26xxXM
4-wire ATM	<ul style="list-style-type: none"> • Cisco 1721 • Cisco 1751 • Cisco 1760 • Cisco 1841 • Cisco 26xxXM • Cisco 2691 • Cisco 28xx • Cisco 3631 • Cisco 37xx • Cisco 38xx

Table 17 lists the Cisco router platforms that are compatible with each mode available on the WIC-1SHDSL-V3 interface card.

Table 17 Cisco router platforms compatible with WIC-1SHDSL-V3 interface card

Mode	Cisco Platforms
2-wire ATM	<ul style="list-style-type: none"> • Cisco 1721 • Cisco 1751 • Cisco 1760 • Cisco 1841 • Cisco 26xxXM • Cisco 2691 • Cisco 28xx • Cisco 37xx • Cisco 38xx
4-wire ATM	<ul style="list-style-type: none"> • Cisco 1721 • Cisco 1751 • Cisco 1760 • Cisco 1841 • Cisco 26xxXM • Cisco 2691 • Cisco 28xx • Cisco 37xx • Cisco 38xx

For a list of the platforms supported by a Cisco interface card refer to *Platform Support for Cisco Interface Cards*.

Finding Support Information for Platforms and Cisco IOS Software Images

Use Cisco Feature Navigator to find information about platform support and Cisco IOS software image support. Access Cisco Feature Navigator at <http://www.cisco.com/go/fn>. You must have an account on Cisco.com. If you do not have an account or have forgotten your username or password, click **Cancel** at the login dialog box and follow the instructions that appear.

G.SHDSL High Speed WICs (HWICs)

The G.SHDSL high speed WICs (HWICs) are available in the following variations:

- The G.SHDSL HWICs support up to four pairs of DSL: two inverse multiplexing over ATM (IMA) lines, and two ATM segmentation and reassembly (SAR) lines. The four DSL pairs are bundled in groups and configured in the Cisco IOS command-line interface (CLI) by using the **dsl-group** command.
 - The HWIC-2SHDSL provides two ports of connectivity through one *RJ-11* connector. It supports *1-Pair* groups or *2-Pair* groups.
 - The HWIC-4SHDSL provides four ports of connectivity through one *RJ-45* connector. It combines four ports of data into one line or two lines with either inverse multiplexing over ATM (IMA) groups or *M-pair* groups, and it supports *1-Pair* groups or *2-Pair* groups.



Note

The Cisco HWIC-2SHDSL provides support for the Dying Gasp feature; however, the Cisco HWIC-4SHDSL does not provide support for this feature. The term *dying gasp* refers to power status as defined in ITU-T standard G.991.2, section 7.1.2.5.3.

LEDs on G.SHDSL HWICs

The G.SHDSL HWICs have 4 LEDs that indicate DSL functionality. Figure 64 and Figure 65 show the front panels and LEDs for the HWIC-2SHDSL and HWIC-4SHDSL. The LED descriptions follow.

Figure 64 HWIC-2SHDSL Front Panel

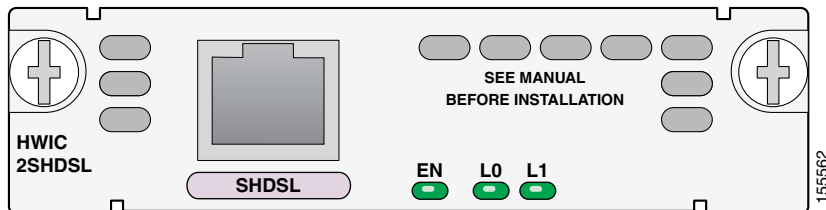
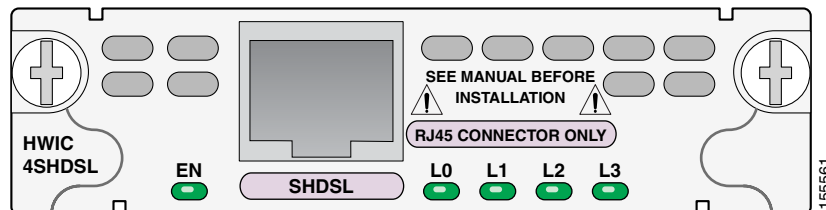

Figure 65 HWIC-4SHDSL Front Panel



EN	Status of the system: Green—Operating system is running. Amber—Interface card is resetting. Blinking—System is initializing.
L0, L1, L2, L3	Status of link: On—Link is active. Off—Link is inactive (disabled). <i>Blinking</i> — Link is training / Link alarm.

Supported Platforms

For a list of the platforms supported by a Cisco interface card refer to *Platform Support for Cisco Interface Cards*.

Finding Support Information for Platforms and Cisco IOS Software Images

Use Cisco Feature Navigator to find information about platform support and Cisco IOS software image support. Access Cisco Feature Navigator at <http://www.cisco.com/go/fn>. You must have an account on Cisco.com. If you do not have an account or have forgotten your username or password, click **Cancel** at the login dialog box and follow the instructions that appear.

ADSL High Speed WICs (HWICs)

ADSL high speed WICs (HWICs) provide ADSL support to platforms with HWIC-enabled interface slots, such as the Cisco 1800 series (modular), Cisco 2800 series, and Cisco 3800 series integrated services routers. Standard ADSL, ADSL2, ADSL2+, and Dying Gasp are supported.

ADSL HWICs are available in the following variations:

- ADSL over POTS (ADSLoPOTS) HWICs
 - HWIC-ADSL, a 1-port ADSLoPOTS card
 - HWIC-ADSL-B/ST, a 2-port card with a port for ADSLoPOTS and a data-only backup port for an ISDN BRI S/T connection
- ADSL over ISDN (ADSLoISDN) HWICs
 - HWIC-ADSLI, a 1-port ADSLoISDN card
 - HWIC-ADSLI-B/ST, a 2-port card with a port for ADSLoISDN and a data-only backup port for an ISDN BRI S/T connection



Note

ADSL HWICs can be inserted only in those interface slots that are enabled to receive HWICs. To determine which slots in your router are enabled to receive HWICs, refer to the *Interface Card Slot Locations and Numbering on Cisco Access Routers* section of the *Overview of Cisco Interface Cards for Access Routers* chapter of the *Cisco Interface Cards Hardware Installation Guide*.

ADSL HWICs are all packaged in Cisco's standard single-wide HWIC form factor.

The ADSL port is connected to the WAN with a straight-through RJ-11 cable supplied with the card. The ISDN port is connected to an NT1 device with a straight-through RJ-45 cable, not supplied.

LEDs on ADSL HWICs

ADSL HWICs have 3 LEDs that indicate DSL functionality. Those ADSL HWICs with a backup ISDN port have three additional LEDs that indicate ISDN functionality.

Figure 66 and Figure 67 show the front panels and LEDs for the ADSLoPOTS and ADSLoISDN HWICs. The LED descriptions are listed in Table 18.

Figure 66 ADSLoPOTS HWIC Front Panel

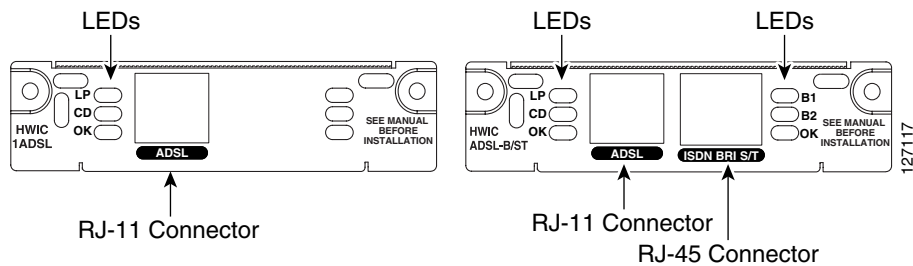

Figure 67 ADSLoISDN HWIC Front Panel

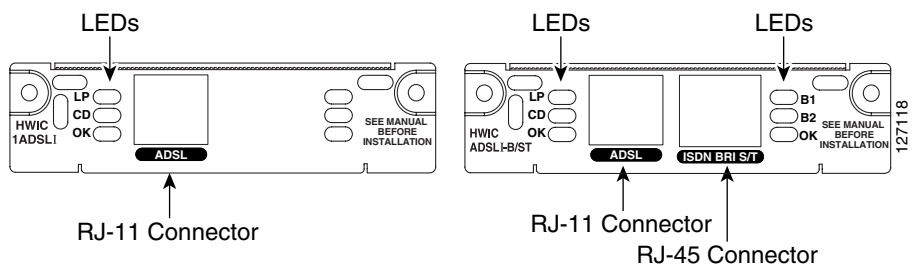

Table 18 ADSL HWIC LEDs

LED	Color	Description
LP	Yellow	DSL interface is in loopback mode.
	Off	Normal operation.
CD	Green	Lit when the unit is connected to the network and operating normally. This LED blinks slowly while downloading ADSL firmware, and blinks rapidly while training with DSLAMs.
OK (ADSL)	Green	Enabled when the card is detected by the router. This LED blinks while downloading firmware.
B1	Green	ISDN port. Blinks with active connection on the first B channel.
B2	Green	ISDN port. Blinks with active connection on the second B channel.
OK (ISDN)	Green	ISDN port has established a connection with the central office switch (D channel).

Supported Platforms

For a list of the platforms supported by a Cisco interface card refer to *Platform Support for Cisco Interface Cards*.

Finding Support Information for Platforms and Cisco IOS Software Images

Use Cisco Feature Navigator to find information about platform support and Cisco IOS software image support. Access Cisco Feature Navigator at <http://www.cisco.com/go/fn>. You must have an account on Cisco.com. If you do not have an account or have forgotten your username or password, click **Cancel** at the login dialog box and follow the instructions that appear.

Cables

The twisted-pair straight-through cable for customer premises equipment (CPE) applications is supplied. The RJ-45-to-RJ-45 BRI cable to connect the ISDN BRI ports on ADSLoISDN HWICs is not supplied. The two-line Y-cable for central office (CO) and 4-wire patch panel applications is not supplied.



Note

The Y-cable must have the wires for pins 3 and 4 twisted together; wires for pins 2 and 5 must also be twisted together. Each pair goes to its own connector at the patch panel end.

Connecting a DSL Interface Card to the Network

See the following sections for information on connecting DSL interface cards to a network.

- Connecting the DSL Ports on WICs and HWICs, page 9
- Connecting the ISDN Ports on HWICs, page 12
- Connecting the SHDSL Port on the G.SHDSL HWICs, page 12

Connecting the DSL Ports on WICs and HWICs

Use a straight-through RJ-11 cable for this connection.

Table 19 shows the ADSL WIC and HWIC pinouts.

Table 19 **ADSL WIC and HWIC Pinouts**

Pin	Signal
3	Tip
4	Ring



Note

If you are connecting an ADSL interface card to an RJ-11 wall jack that has the DSL pair wired for pins 2 and 5, you must use an RJ-11 crossover cable (lavender with blue stripe). The RJ-11 crossover cable is orderable separately as a spare.

Table 20 shows the WIC-1SHDSL pinouts.

Table 20 **WIC-1SHDSL Pinouts**

Pin	Signal
3	Tip
4	Ring

Table 21 shows the RJ-14C pinouts on the WIC-1SHDSL-V2 and WIC-1SHDSL-V3 interface cards.

Table 21 **WIC-1SHDSL-V2 RJ-14C Pinouts**

Pins	Signal	Line
3 and 4	3 = Tip, 4 = Ring	0
2 and 5	2 = Tip, 5 = Ring	1

Table 22 shows the RJ-11 pinouts on the WIC-1SHDSL-V2 and WIC-1SHDSL-V3 interface cards.

Table 22 **WIC-1SHDSL-V2 RJ-11 Pinouts**

Pins	Signal	Line
2 and 3	2 = Tip, 3 = Ring	0
1 and 4	1 = Tip, 4 = Ring	1

To connect a DSL interface card to the WAN, complete the following steps:

- Step 1** Confirm that the router is turned off.



Warning

To comply with the Telcordia GR-1089 NEBS standard for electromagnetic compatibility and safety, connect the HWIC-2SHDSL and HWIC-4SHDSL interface cards only to intra-building or unexposed wiring or cable. The intra-building port(s) of the equipment or subassembly must not be metallically connected to interfaces that connect to the OSP or its wiring. These interfaces are designed for use as intra-building interfaces only (Type 2 or Type 4 ports as described in GR-1089-CORE, Issue 4) and require isolation from the exposed OSP cabling. The addition of Primary Protectors is not sufficient protection in order to connect these interfaces metallically to OSP wiring.

- Step 2** Connect one end of the cable to the ADSL or G.SHDSL port on the card.

Step 3 Connect the other end to the wall jack (RJ-11) at your site, as shown in Figure 68.

Figure 68 Connecting an ADSL Card to the Wall Jack

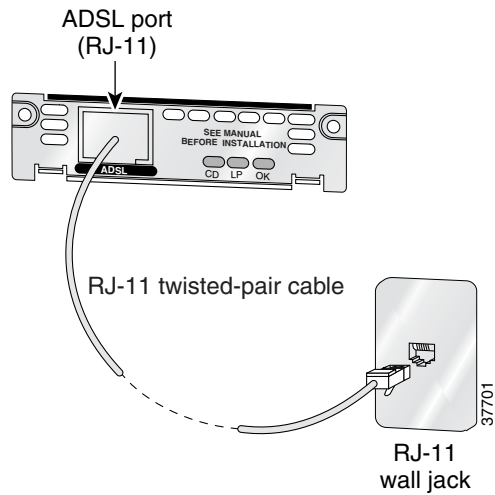

Alternately, when connecting a G.SHDSL card to a 4-wire patch panel, use a Y-cable as shown in Figure 69.

Figure 69 Connecting a G.SHDSL Card to a Patch Panel With a Y-Cable

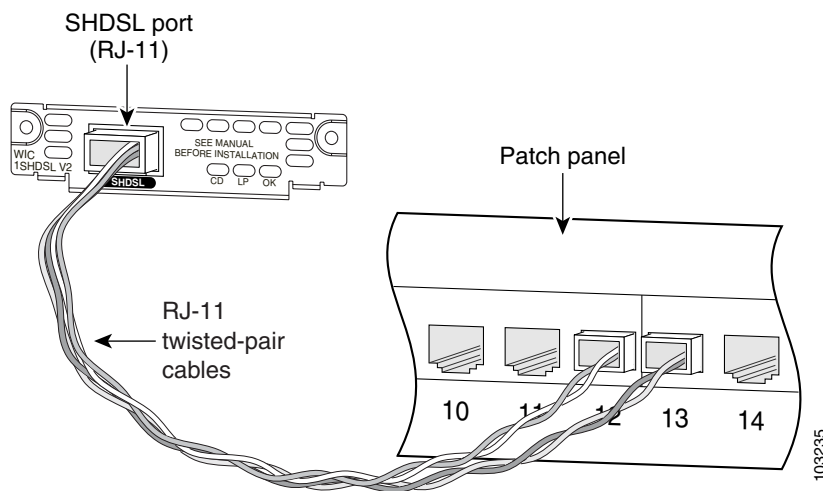

Step 4 Turn on power to the router.

Step 5 To connect the card to the network, you must configure the DSL interface card in the router to the no shutdown state. Enter the **no shut** command in the router configuration. Verify that the CD LED comes on, indicating that the interface card is connected to the network.



Note Step 5 does not apply to the WIC-1SHDSL-V2 or WIC-1SHDSL-V3.

Connecting the ISDN Ports on HWICs

Use an RJ-45-to-RJ-45 BRI cable (not included) to connect the ISDN BRI port to an ISDN NT1 device. Refer to the online document *Cisco Modular Access Router Cable Specifications* for pinouts.

To connect an ISDN BRI S/T port to the WAN, follow these steps:

Step 1 Confirm that the router is turned off.



Warning

To comply with the Telcordia GR-1089 NEBS standard for electromagnetic compatibility and safety, connect the HWIC-ADSL-B/ST or HWIC-ADSLI-B/ST ISDN BRI S/T port only to intra-building or unexposed wiring or cable. The intra-building port(s) of the equipment or subassembly must not be metallically connected to interfaces that connect to the OSP or its wiring. These interfaces are designed for use as intra-building interfaces only (Type 2 or Type 4 ports as described in GR-1089-CORE, Issue 4) and require isolation from the exposed OSP cabling. The addition of Primary Protectors is not sufficient protection in order to connect these interfaces metallically to OSP wiring.

Step 2 Connect one end of a straight-through RJ-45-to-RJ-45 cable to the S/T interface.

Step 3 Connect the other end of the cable to the NT1 device, as shown in Figure 70.

Figure 70 Connecting the BRI S/T Port

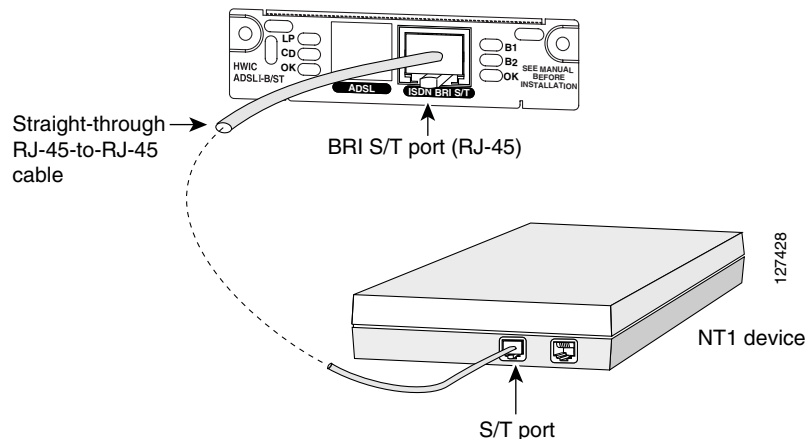

Step 4 Connect the NT1 device to the ISDN wall jack according to the documentation that came with the NT1 device.

Step 5 Turn on power to the router.

Connecting the SHDSL Port on the G.SHDSL HWICs

Connect Cisco G.SHDSL HWICs as described next:

- Cisco HWIC-2SHDSL—Use a standard *RJ-11* straight-through cable to establish connection between the HWIC and a network device.
- Cisco HWIC-4SHDSL—Use a standard *RJ-45* straight-through cable to establish connection between the HWIC and a network device.

Warning

To comply with the Telcordia GR-1089 NEBS standard for electromagnetic compatibility and safety, connect the HWIC-2SHDSL and HWIC-4SHDSL interface cards only to intra-building or unexposed wiring or cable. The intra-building port(s) of the equipment or subassembly must not be metallicly connected to interfaces that connect to the OSP or its wiring. These interfaces are designed for use as intra-building interfaces only (Type 2 or Type 4 ports as described in GR-1089-CORE, Issue 4) and require isolation from the exposed OSP cabling. The addition of Primary Protectors is not sufficient protection in order to connect these interfaces metallicly to OSP wiring.

Figure 71 shows the *RJ-45* pin assignment. Table 23 identifies the *RJ-45* signal assignment by pin.

Caution

Inserting an *RJ-11* connector into the Cisco HWIC-4SHDSL port may deform pins 1 and 8, which may prevent solid contact between the connector and the plug in subsequent connections. If solid contact is prevented, line -1 tip and line -3 ring will not work properly.

Figure 71 *RJ-45 Pin Assignment*

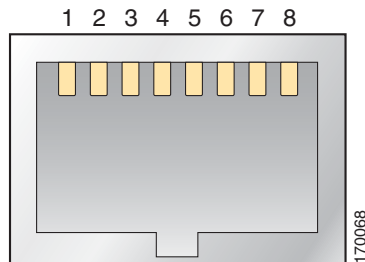

Table 23 *RJ-45 Signal Assignment by Pin*

Pin	Signal
1	Line 1 tip
2	Line 1 ring
3	Line 2 tip
4	Line 0 tip
5	Line 0 ring
6	Line 2 ring
7	Line 3 tip
8	Line 3 ring

To connect the Cisco HWIC-4SHDSL with a DSLAM that supports two or four *RJ-11* connections, modify the standard *RJ-45* cable, using one of the following diagrams as applicable:

- Figure 72 shows how to modify the cable and connect the Cisco HWIC-4SHDSL with a DSLAM that supports four *RJ-11* cable connections.
- Figure 73 shows how to modify the cable and connect the Cisco HWIC-4SHDSL with a DSLAM that supports two *RJ-11* cable connections.

Figure 72 Standard *RJ-45* Connector to Four Standard *RJ-11* Connectors

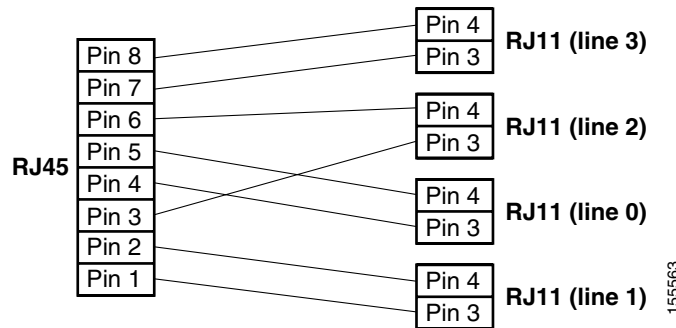
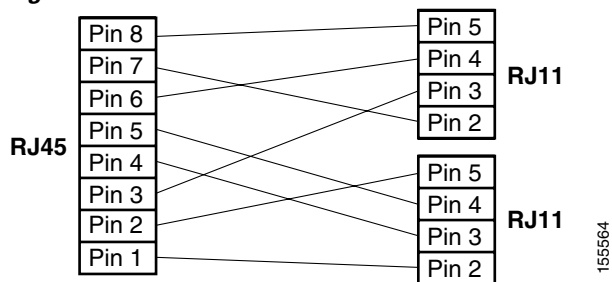

Figure 73 Standard *RJ-45* Connector to Two Standard *RJ-11* Connectors



Using POTS Splitters and Microfilters with an ADSL-over-POTS WIC (WIC-1ADSL)

POTS splitters and microfilters apply to the ADSL-over-POTS WIC only. They are used on telephone lines to ensure voice- and data-call quality. POTS splitters result in the best data and voice performance when the router and the telephone are used on the same telephone line.

POTS Splitters

A POTS splitter (also called a *splitter*) is installed on a telephone line that is connected to both data (high-frequency) and voice (low-frequency) devices. The splitter routes the high-frequency and low-frequency signals on the telephone line to the correct device. Signals intended for the router can disrupt voice calls; signals intended for voice calls can affect router operation.

Most splitters must be installed by the telephone company; however, some splitters can be installed by the customer. If you are not sure what type of splitter to use, contact your service provider.

Figure 74 is an example of a type of POTS splitter that is installed at the customer premises by the customer. Other types of POTS splitters are installed by the telephone company on an exterior wall of the customer premises.

Figure 74 POTS Splitters

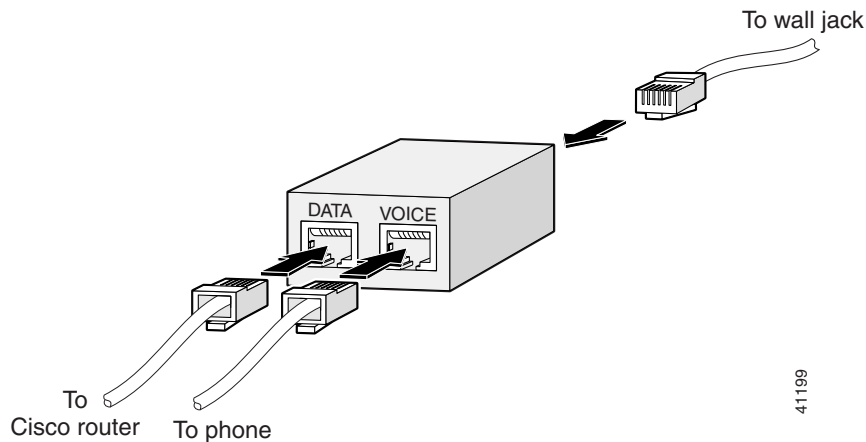

Microfilters

Microfilters are installed on telephones to improve voice-call quality when voice and data equipment are using the same telephone line (twisted pair). You should use microfilters only when the two following conditions exist:

- The documentation for the telephone you are using with the router states that microfilters should be used with the phone.
- Poor telephone call quality can be resolved by installing a microfilter on the phone line.

Figure 75 shows one type of microfilter.

Figure 75 Microfilter

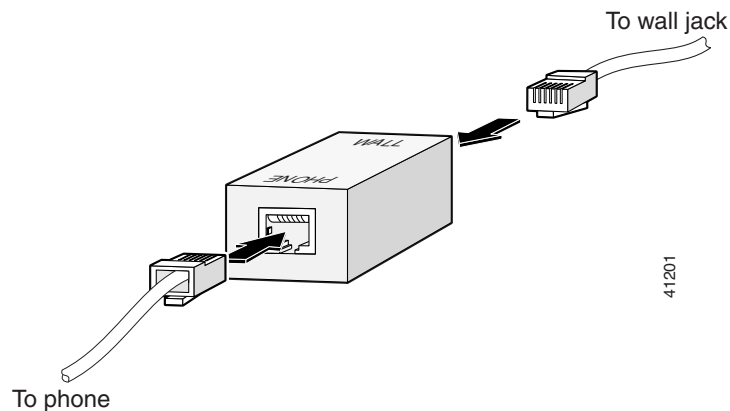

Common Splitter and Microfilter Configurations

This section describes the most common scenarios for using splitters and microfilters. The scenarios are listed from most common to least common.

Telephone Company-Installed Splitter

This scenario is described below and illustrated in Figure 76.

- The telephone company has provisioned a single copper pair to be used by both the telephone (POTS) service and the router with a DSL interface card, so a POTS splitter must be installed.
- The splitter is installed by the telephone company on the customer premises. This type of splitter is also referred to as a *network interface device (NID)*.
- The router and telephone are on separate lines (twisted pair) to the splitter.
- The router and telephone share the same telephone line (twisted pair) to the telephone company.

Figure 76 Telephone Company-Installed Splitter

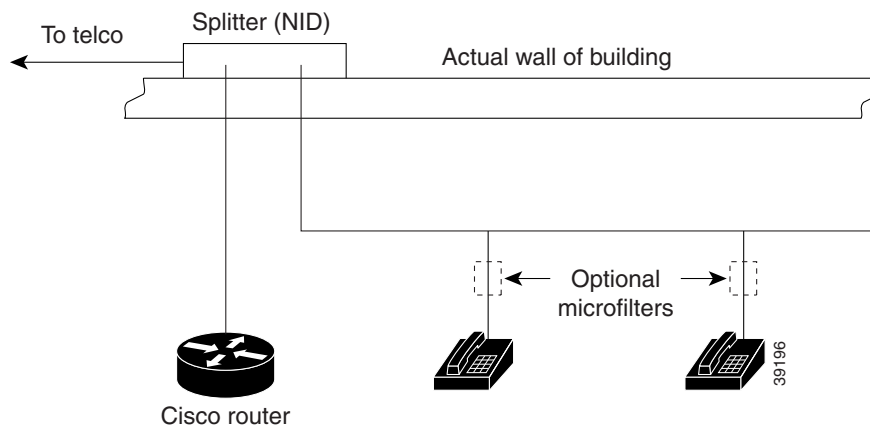

Customer-Installed Splitter

This scenario is described below and illustrated in Figure 77.

- The telephone company has provisioned a single copper pair to be used by both the telephone (POTS) service and the router with a DSL interface card, so a POTS splitter must be installed.
- The splitter is installed by the customer on the customer premises.
- The router and telephone are directly connected to the splitter, which is connected to the telephone line.
- The router and telephone share the same telephone line (twisted pair) to the telephone company.
- For optional telephones connected through the splitter, microfilters are optional. They should be installed only if they improve telephone call quality.
- For telephones connected directly to the telephone line, microfilters are required.

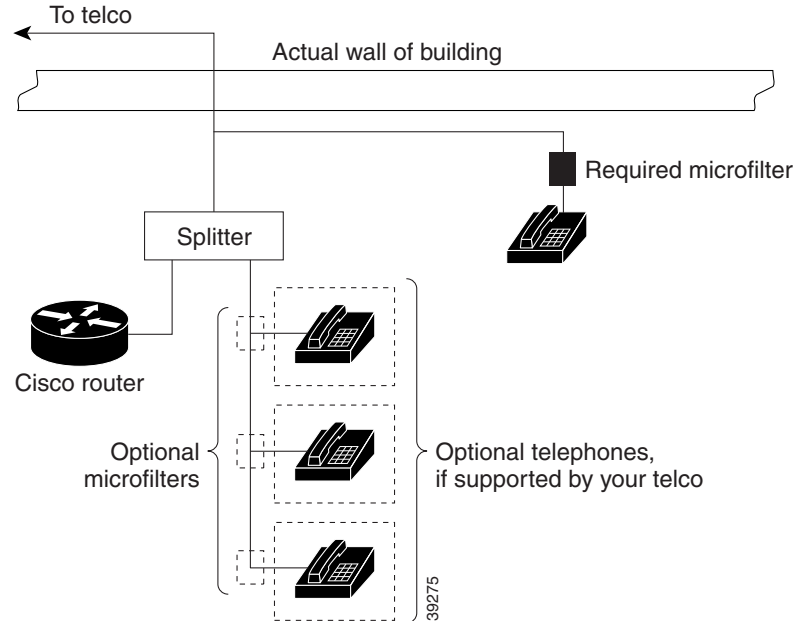
Figure 77 *Customer-Installed Splitter*

Router and Telephone Using Separate Telephone Lines

This scenario is described below and illustrated in Figure 78.

- The telephone company has provisioned a single copper pair to be used exclusively by the router with a DSL interface card and a separate copper pair to be used exclusively by the telephone (POTS) service; therefore, neither a POTS splitter nor a microfilter is needed.
- The microfilter is optional; it should be installed only if it improves telephone call quality.

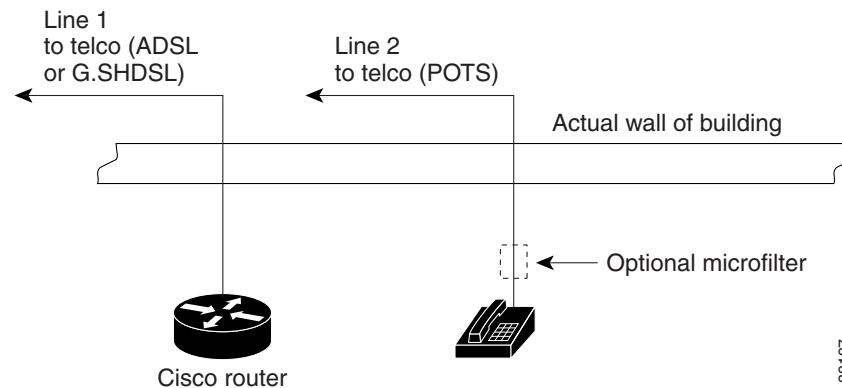
Figure 78 *No Splitter, Optional Microfilter*

Related Documentation

Related documentation is available on Cisco.com or on the Product Documentation DVD. For more information, see the “Obtaining Documentation, Obtaining Support, and Security Guidelines” section on page 19.

Feature Modules

- *Configuring Cisco G.SHDSL HWICs in Cisco Access Routers*
- *1-Port ADSL WAN Interface Card for Cisco 2600 Series and Cisco 3600 Series Routers*, Cisco IOS Release 12.2(4)T
- *1-Port ADSL WAN Interface Card*, Cisco IOS Releases 12.1(3)XJ and 12.2(2)T
- *1-Port ADSL WAN Interface Card*, Cisco IOS Release 12.1(5)YB
- *ATM Mode for Two-Wire or Four-Wire SHDSL*, Cisco IOS Release 12.3(7)T
- *T1/E1 Mode for SHDSL*, Cisco IOS Release 12.3(7)T
- *1-Port G.SHDSL WAN Interface Card for Cisco 2600 Series Routers*, Cisco IOS Release 12.2(4)XL
- *Enhanced Voice and QoS for ADSL and G.SHDSL*, Cisco IOS Release 12.3(2)T
- *Enhanced Voice and QoS for ADSL and G.SHDSL on Cisco 1700 Series, Cisco 2600 Series, Cisco 3600 Series, and Cisco 3700 Series Routers*, Cisco IOS Releases 12.2(8)YN and 12.2(13)T
- *Voice and Quality of Service Features for ADSL and G.SHDSL on Cisco 1700, Cisco 2600, and Cisco 3600 Series Routers*, Cisco IOS Releases 12.2(4)XL and 12.2(13)T

Sample Configurations

- *Configuring IPsec Over ADSL on a Cisco 2600/3600 With ADSL-WIC and Hardware Encryption Modules*
- *Configuring a Cisco 1700/2600/3600 ADSL WIC With a Single IP Address, DHCP, PPPoA, and PPP-PAP*
- *Configuring a Cisco 1700/2600/3600 ADSL WIC With IP Unnumbered E0, DHCP, PPPoA, and PPP-PAP*
- *Configuring a Cisco 1700/2600/3600 ADSL WIC With IP Unnumbered E0, PPPoA, PPP-PAP, and Manually Configured Local LAN Devices*
- *Configuring a Cisco 1700/2600/3600 ADSL WIC (Unnumbered Interface) With RFC1483 Routing Using AAL5SNAP Protocol IP*
- *Configuring a Cisco 1700/2600/3600 ADSL WIC With RFC1483 Routing Using AAL5SNAP Protocol IP*
- *Configuring a Cisco 1700/2600/3600 ADSL WIC Using PPPoA With CHAP and PAP*
- *Configuring a Cisco 1700/2600/3600 ADSL WIC With IRB and NAT Using RFC1483 Bridging*
- *Configuring a Cisco 1700/2600/3600 ADSL WIC With NAT, a DHCP Server, and Easy IP Using PPPoA (aal5mux ppp)*
- *Configuring a Cisco 1700/2600/3600 ADSL WIC as a PPPoE Client With NAT*,
- *Configuring Network Address Translation and Static Port Address Translation to Support an Internal Web Server*

- *Configuring a Cisco 1700/2600/3600 ADSL WIC With AAL5MUX IP Routing, Multiple PVCs, and Terminating on a Cisco 6400 UAC-NRP*
- *Configuring a Cisco 1700/2600/3600 ADSL WIC to Support PPPoE Clients, Terminating on a Cisco 6400 UAC*
- *Configuring a Cisco 1700/2600/3600 ADSL WIC and a Cisco 6400 Configured With IRB Using RFC1483 Bridging (aal5snap)*
- *Configuring a Cisco 1700/2600/3600 ADSL WIC and a Cisco 6400 in RBE Mode Using RFC1483 Bridging*

Obtaining Documentation, Obtaining Support, and Security Guidelines

For information on obtaining documentation, obtaining support, providing documentation feedback, security guidelines, and also recommended aliases and general Cisco documents, see the monthly *What's New in Cisco Product Documentation*, which also lists all new and revised Cisco technical documentation, at:

<http://www.cisco.com/en/US/docs/general/whatsnew/whatsnew.html>

CCVP, the Cisco logo, and Welcome to the Human Network are trademarks of Cisco Systems, Inc.; Changing the Way We Work, Live, Play, and Learn is a service mark of Cisco Systems, Inc.; and Access Registrar, Aironet, Catalyst, CCDA, CCDP, CCIE, CCIP, CCNA, CCNP, CCSP, Cisco, the Cisco Certified Internetwork Expert logo, Cisco IOS, Cisco Press, Cisco Systems, Cisco Systems Capital, the Cisco Systems logo, Cisco Unity, Enterprise/Solver, EtherChannel, EtherFast, EtherSwitch, Fast Step, Follow Me Browsing, FormShare, GigaDrive, HomeLink, Internet Quotient, IOS, iPhone, IP/TV, iQ Expertise, the iQ logo, iQ Net Readiness Scorecard, iQuick Study, LightStream, Linksys, MeetingPlace, MGX, Networkers, Networking Academy, Network Registrar, PIX, ProConnect, ScriptShare, SMARTnet, StackWise, The Fastest Way to Increase Your Internet Quotient, and TransPath are registered trademarks of Cisco Systems, Inc. and/or its affiliates in the United States and certain other countries.

All other trademarks mentioned in this document or Website are the property of their respective owners. The use of the word partner does not imply a partnership relationship between Cisco and any other company. (0711R)

Any Internet Protocol (IP) addresses used in this document are not intended to be actual addresses. Any examples, command display output, and figures included in the document are shown for illustrative purposes only. Any use of actual IP addresses in illustrative content is unintentional and coincidental.

© 2007 Cisco Systems, Inc. All rights reserved.



Voice Interface Cards

Revised: 6/7/07, OL-12847-01

Overview

Voice network modules convert telephone voice signals into a form that can be transmitted over an IP network, and have no connectors. Voice interface cards (VICs) provide the connection to the telephone equipment or network.

This document describes Cisco voice interface cards and how to connect Cisco voice interface cards to a network, and contains the following sections:

- Grounding Requirements for Voice Interface Cards, page 1
- Foreign Exchange Station (FXS) Interface Cards, page 3
- Foreign Exchange Office (FXO) Interface Cards, page 5
- Receive and Transmit (E&M) Interface Cards, page 7
- FXS, FXO, and E&M Interface Card LEDs, page 9
- ISDN BRI Interface Cards, page 9
- Analog Direct Inward Dial (DID) Interface Cards, page 13
- Multiflex Trunk Interface Cards, page 15
- Centralized Automated Message Accounting Trunk Protocol Interface Cards, page 18
- Related Documentation, page 19

Grounding Requirements for Voice Interface Cards

This section tells where to find instructions on how to properly ground voice interface cards on the following platforms:

- Cisco 1700 Series Routers
- Cisco 2600 Series, Cisco 3600 Series, and Cisco 3700 Series Routers
- Cisco ICS 7750



Warning

Do not work on the system or connect or disconnect cables during periods of lightning activity.

**Warning**

To avoid electric shock, do not connect safety extra-low voltage (SELV) circuits to telephone-network voltage (TNV) circuits. LAN ports contain SELV circuits, and WAN ports contain TNV circuits. Some LAN and WAN ports both use RJ-45 connectors. Use caution when connecting cables.

**Warning**

To reduce the risk of fire, use only No. 26 AWG or larger telecommunication line cord.

**Warning**

Hazardous network voltages are present in WAN ports regardless of whether power to the unit is OFF or ON. To avoid electric shock, use caution when working near WAN ports. When detaching cables, detach the end away from the unit first.

Cisco 1700 Series Routers

Grounding on a Cisco 1700 series router is done on the router chassis itself, not on the voice interface cards. For information on chassis grounding on Cisco 1700 series routers, see the hardware installation guide for your router.

Cisco 2600 Series, Cisco 3600 Series, and Cisco 3700 Series Routers

The requirements in this section apply to only the Cisco 2600 series, Cisco 3600 series, and Cisco 3700 series routers.

The cards in this chapter are suitable for exposed plant lead connection. However, the host router chassis must have a permanent protective earth connection before you connect a voice interface card to an exposed plant lead. Make sure that a permanent earth connection is in place before installing the card.

If you find that a router chassis does not have an earth connection and you do not have a grounding kit, take one of the following actions:

- Order and install a NEBS Level 3/ETSI Compliance Kit.
- Install an equivalent permanent protective earth connection, using the method described in the installation guide *Installing the Grounding Lug on Cisco 2600 and Cisco 3600 Series Routers*.

Cisco ICS 7750

The Cisco ICS 7750 chassis has a grounding lug that needs to be properly connected using a green and yellow 14 American Wire Gauge (AWG) grounding wire. See the “Installing the Cisco ICS 7750” chapter in the *Cisco ICS 7750 Hardware Installation Guide*.

Pinout and Cabling Specifications

**Note**

Refer to the *Cisco Modular Access Router Specifications* for network-end connectors and pinouts of the cables connecting voice cards. Look under the type of interface card.

Foreign Exchange Station (FXS) Interface Cards

A Foreign Exchange Station (FXS) interface connects directly to a standard telephone, fax machine, or similar device. This interface supplies ringing voltage, dial tone, and so on to the station. The ports are shown in Figure 79, Figure 80, and Figure 81.



Caution

To comply with the Telcordia GR-1089 NEBS standard for electromagnetic compatibility and safety, connect the 2-port FXS cards (VIC-2FXS and VIC2-2FXS) and 4-port FXS/DID cards (VIC-4FXS/DID) only to intrabuilding or non-exposed wiring or cabling. The intrabuilding cable must be shielded and the shield must be grounded at both ends.



Note

Each port on the 4-port FXS/DID VIC can be configured as either Foreign Exchange Station (FXS) or Direct Inward Dial (DID) when it is used with phones with a Ringer Equivalence Number (REN) load of 1 or less.

If the REN load on any port is greater than 1, all four ports must be configured as either FXS or DID. For information about using analog DID with the 4-port FXS/DID VIC, see the “Analog Direct Inward Dial (DID) Interface Cards” section on page 13.



Note

Cisco 2600XM series, Cisco 2691, Cisco 2800 series, Cisco 3600 series, Cisco 3700 series, and Cisco 3800 series routers support DID on the 4-port FXS/DID cards in Cisco IOS Release 12.3(14)T and later.



Note

The Cisco 1751 router can support three 4-port FXS/DID VICs, up to a maximum of four DID ports. The Cisco 1760 router can support four 4-port FXS/DID VICs, up to a maximum of eight DID ports.



Note

The Cisco ICS 7750 also supports 8 FXS ports on the analog station interface 81 (ASI 81), and 16 FXS ports on the ASI 160. See the “Processor Cards Feature Summary” chapter in the *Cisco ICS 7750 System Description* document.

Figure 79 2-Port FXS Card Front Panel (VIC-2FXS)

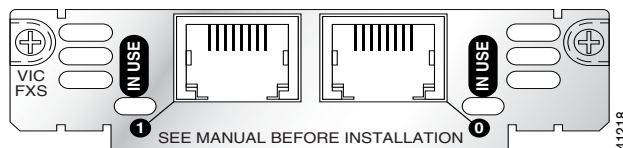

Figure 80 2-Port FXS Card Front Panel (VIC2-2FXS)

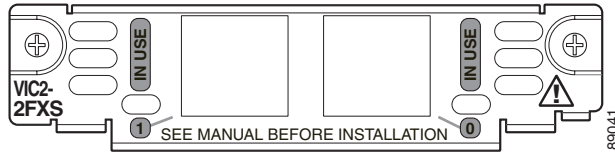
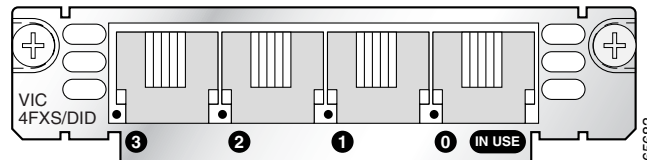

Figure 81 4-Port FXS/DID Card Front Panel (VIC-4FXS/DID)



Connecting FXS Cards

Use a standard straight-through RJ-11 modular telephone cable to connect a VIC-2FXS, VIC-4FXS/DID, or VIC2-2FXS to a telephone or fax machine.



Warning

This equipment contains a ring signal generator (ringer), which is a source of hazardous voltage. Do not touch the RJ-11 (phone) port wires (conductors), the conductors of a cable connected to the RJ-11 port, or the associated circuit-board when the ringer is active. The ringer is activated by an incoming call.



Warning

For connections outside the building where the equipment is installed, the following ports must be connected through an approved network termination unit with integral circuit protection: FXS.



Note

Ports on this interface card are colored gray.

Step 1

Confirm that the router is still turned off.



Caution

To comply with the Telcordia GR-1089 NEBS standard for electromagnetic compatibility and safety, connect the 2-port FXS cards (VIC-2FXS and VIC2-2FXS) and 4-port FXS/DID cards (VIC-4FXS/DID) only to intra-building or non-exposed wiring or cabling. The intrabuilding cable must be shielded and the shield must be grounded at both ends.

Step 2

Connect one end of the straight-through RJ-11 cable to an RJ-11 port on the card. (See Figure 82.)

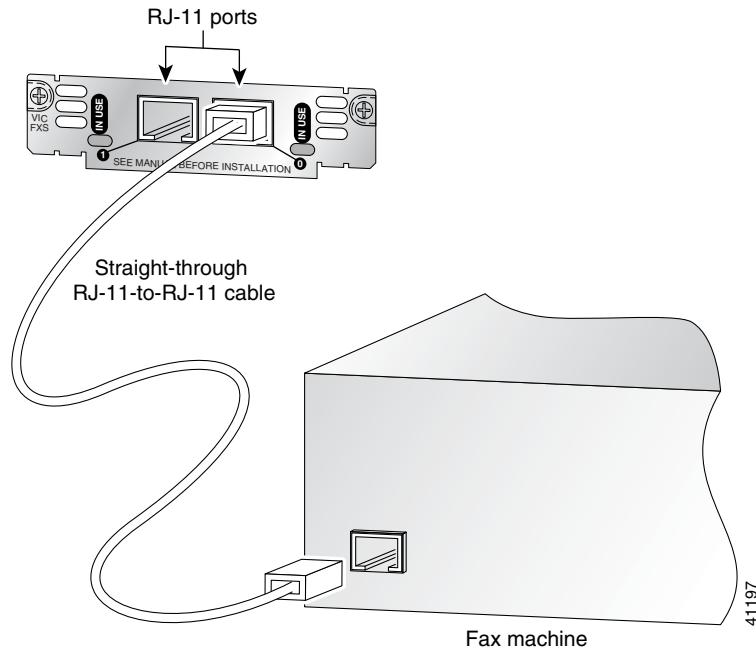
Figure 82 Connecting an FXS Card

Step 3 Connect the other end of the cable to the RJ-11 port on the telephone or fax machine.

Foreign Exchange Office (FXO) Interface Cards

A Foreign Exchange Office (FXO) interface connects local calls to a central office or PBX. This is the interface a standard telephone provides. This type of card is illustrated in Figure 83, Figure 84, and Figure 85.

The VIC-2FXO and VIC-2FXO-M1 interface cards are intended for use in North America (United States, Canada, and Mexico).

The VIC-2FXO-EU and VIC-2FXO-M2 interface cards are intended for use in Europe.

The VIC-2FXO-M3 interface card is intended for use in Australia.

The VIC2-2FXO and VIC2-4FXO interface cards are software-configurable for all regions (see Figure 84 and Figure 85).



Caution

To comply with the Telcordia GR-1089 NEBS standard for electromagnetic compatibility and safety, connect the 2-port FXO card (VIC2-2FXO) only to intra-building or non-exposed wiring or cabling. The intrabuilding cable must be shielded and the shield must be grounded at both ends.



Warning

This equipment contains a ring signal generator (ringer), which is a source of hazardous voltage. Do not touch the RJ-11 (phone) port wires (conductors), the conductors of a cable connected to the RJ-11 port, or the associated circuit-board when the ringer is active. The ringer is activated by an incoming call.

**Warning**

For connections outside the building where the equipment is installed, the following ports must be connected through an approved network termination unit with integral circuit protection.
FXO

Figure 83 2-Port FXO Card Front Panel (VIC-2FXO)

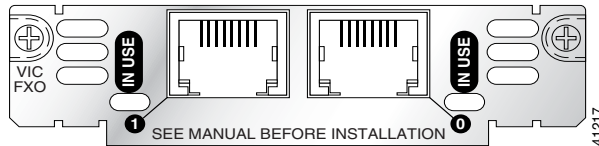

Figure 84 2-Port FXO Card Front Panel (VIC2-2FXO)

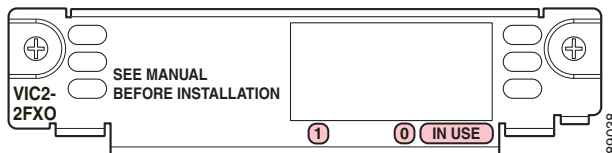
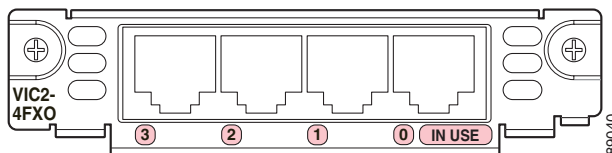

Figure 85 4-Port FXO Card Front Panel (VIC2-4FXO)



Setting Jumpers on the 2-Port FXO Card

**Note**

This information does not apply to the VIC2-2FXO card.

The FXO voice interface card includes two jumper headers, W3 and W4, to set loop-start or ground-start mode. One jumper configures each FXO port. The default setting is loop-start, which should be satisfactory in most installations. In this setting, jumpers are placed over positions 2 and 3 of headers W3 and W4.

Most modern central office equipment, such as DMS-100 and 5ESS switches, provides calling party control (CPC) and Ring on Seize on loop-start lines. CPC allows quicker disconnection, and Ring on Seize minimizes glare (collision of inbound and outbound calls on the same interface).

If your central office does not provide these features on loop-start, you may want to configure the FXO card for ground-start operation instead by moving the jumpers to positions 1 and 2.

For proper operation, both jumpers on the VIC-2FXO card must be configured identically.

**Note**

This setting does not apply to VIC-2FXO-EU and VIC-2FXO-M2 interface cards.

Connecting FXO Cards

Use a straight-through RJ-11 cable to connect the FXO voice interface card to the PSTN or PBX through a telephone wall outlet.



Note Ports on this interface card are colored pink.

Step 1 Confirm that the router is still turned off.



Caution To comply with the Telcordia GR-1089 NEBS standard for electromagnetic compatibility and safety, connect the 2-port FXO card (VIC2-2FXO) only to intra-building or non-exposed wiring or cabling. The intrabuilding cable must be shielded and the shield must be grounded at both ends.

Step 2 Connect one end of the straight-through RJ-11 cable to an RJ-11 port on the card. (See Figure 86.)

Figure 86 Connecting an FXO Card

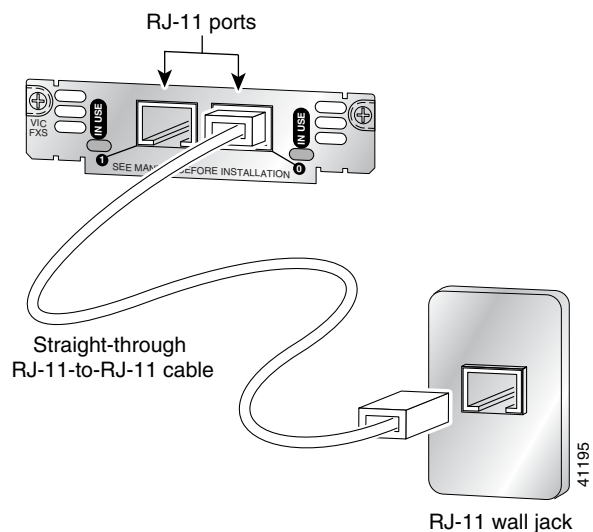

Step 3 Connect the other end to an RJ-11 telephone wall outlet.

Receive and Transmit (E&M) Interface Cards

ReCEive and transMit (E&M) is a signaling technique for two-wire and four-wire telephone and trunk interfaces. The E&M interface typically connects remote calls from an IP network to a PBX. The cards are illustrated in Figure 87 and Figure 88.



Caution To comply with the Telcordia GR-1089 NEBS standard for electromagnetic compatibility and safety, connect the 2-port E&M card (VIC2-2E/M) only to intra-building or non-exposed wiring or cabling. The intrabuilding cable must be shielded and the shield must be grounded at both ends.

Figure 87 2-Port E&M Card Front Panel (VIC-2E/M)

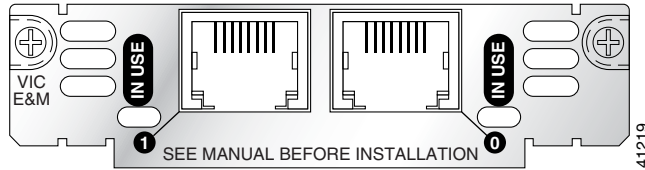
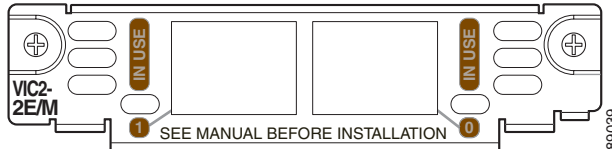

Figure 88 2-Port E&M Card Front Panel (VIC2-2E/M)



Connecting E&M Interface Cards

Use a straight-through RJ-48C cable to connect the E&M card to the PSTN or PBX through a telephone wall outlet.



Caution

Do not connect an E&M interface directly to the PSTN.



Note

Ports on the E&M voice interface card are colored brown.

Step 1

Confirm that the router is still turned off.



Caution

To comply with the Telcordia GR-1089 NEBS standard for electromagnetic compatibility and safety, connect the 2-port E&M card (VIC2-2E/M) only to intra-building or non-exposed wiring or cabling. The intrabuilding cable must be shielded and the shield must be grounded at both ends.

Step 2

Connect one end of the straight-through RJ-48C-to-RJ-48C cable to an RJ-48C port on the card. (See Figure 89.)

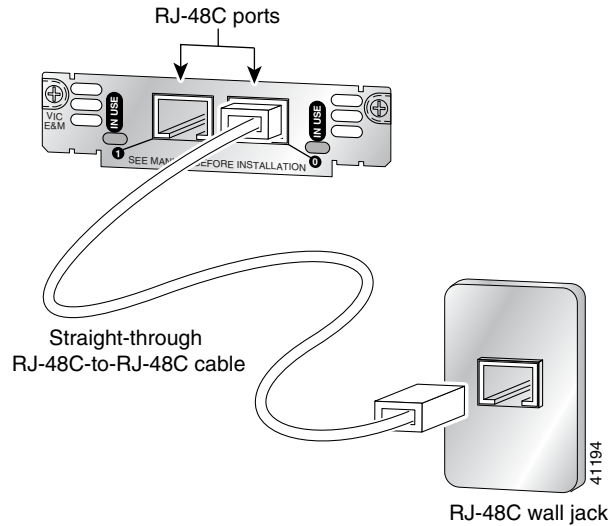
Figure 89 Connecting the 2-Port E&M Card

Step 3 Connect the other end of the cable to an RJ-48C wall outlet.

FXS, FXO, and E&M Interface Card LEDs

Each voice interface card has IN USE LEDs, one for each port. These LEDs have three states: green when active, off when ready for use, and amber when not ready for use. Figure 90 shows a voice interface card with an E&M interface as an example.

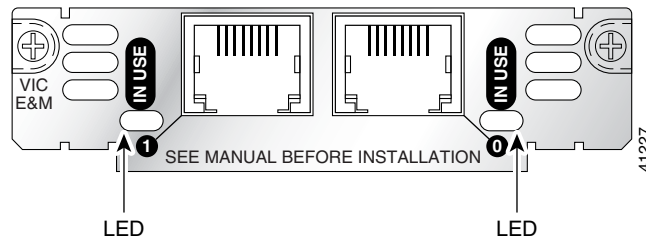
Figure 90 Voice Interface Card LEDs

ISDN BRI Interface Cards

The ISDN BRI S/T voice interface card provides a client-side (TE) ISDN S/T physical interface for connection to an NT1 device terminating an ISDN telephone network. Each port on the interface card can carry two voice calls (one over each ISDN B channel), for a total of four calls per ISDN BRI card.

ISDN BRI NT/TE voice interface cards (VIC-2BRI-NT/TE and VIC2-2BRI-NT/TE) have the same capabilities as the S/T card, but can also be configured to provide a network termination (NT) interface with phantom power.

The Cisco 1751 and Cisco 1760 routers, and the Cisco ICS 7750 platform support both ISDN BRI NT/TE voice interface cards. You can install these cards in any interface card slot in these platforms. These platforms do not support the ISDN BRI S/T voice interface card.

The ISDN BRI NT/TE cards are illustrated in Figure 91 and Figure 92.



Caution

To comply with the Telcordia GR-1089 NEBS standard for electromagnetic compatibility and safety, connect the 2-port ISDN BRI card (VIC2-2BRI-NT/TE) only to intra-building or non-exposed wiring or cabling. The intrabuilding cable must be shielded and the shield must be grounded at both ends.

Figure 91 2-Port ISDN BRI Card Front Panel (VIC-2BRI-NT/TE)

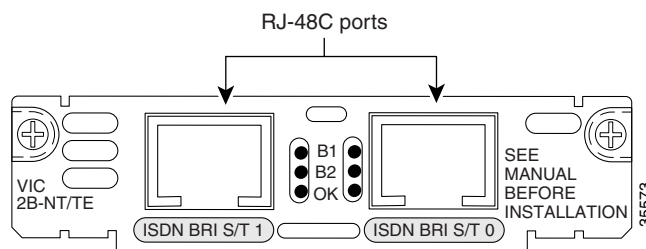
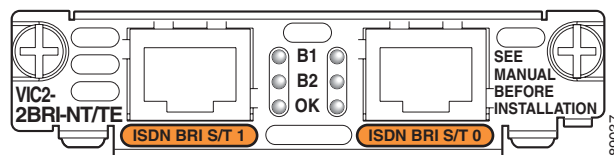

Figure 92 2-Port ISDN BRI Card Front Panel (VIC2-2BRI-NT/TE)



ISDN BRI Card Considerations



Note

Cisco ISDN BRI interface cards support voice ISDN traffic only.



Note

The ISDN BRI restrictions in this section do not apply to the VIC2-2BRI-NT/TE voice interface cards.



Note

The ISDN BRI restrictions in this section do not apply to the Cisco 1751, Cisco 1760, or Cisco ICS 7750 platforms.

To use all four voice channels, you must install the ISDN BRI card in slot 0 of a two-slot voice network module (NM-2V). Slot 1 should remain empty.



Note

If slot 0 is unoccupied, the system treats it as a pair of analog voice ports.

If you install any of the following configurations, the Cisco IOS software disables certain ports, as shown in Table 24:

- An ISDN BRI voice interface card in a 1-slot voice network module (NM-1V)
- Two ISDN BRI voice interface cards in a 2-slot voice network module (NM-2V)
- One ISDN BRI voice interface card and one analog voice interface card (VIC-2FXS, VIC-2FXO, VIC-2FXO-EU, VIC-2FXO-M3, or VIC-2E/M) in a 2-slot voice network module (NM-2V)

Table 24 How Cisco IOS Software Handles Voice Interface Card Ports

Network Module	Slot	Voice Interface Card	Port	Status
NM-1V	0	VIC-2BRI-S/T-TE, VIC-2BRI-NT/TE	0	Up
			1	Down
NM-2V	0	VIC-2BRI-S/T-TE, VIC-2BRI-NT/TE	0	Up
			1	Up
NM-2V	0	VIC-2BRI-S/T-TE, VIC-2BRI-NT/TE	0	Up
			1	Up
	1	VIC-2BRI-S/T-TE, VIC-2BRI-NT/TE	0	Down
			1	Down
NM-2V	0	VIC-2BRI-S/T-TE, VIC-2BRI-NT/TE	0	Up
			1	Up
	1	Analog voice interface card	0	Down
			1	Down
NM-2V	0	Analog voice interface card	0	Up
			1	Up
	1	VIC-2BRI-S/T-TE, VIC-2BRI-NT/TE	0	Up
			1	Down

Connecting ISDN BRI Interface Cards

Use a straight-through RJ-45 cable to connect ISDN BRI cards to the ISDN network through a telephone wall outlet or other device.



Caution

To prevent damage to the router, be sure to connect the BRI cable to the BRI connector only, and not to any other RJ-45 connector.

To connect the 2-port ISDN BRI card to the router, follow these steps:

Step 1

Confirm that the router is still turned off.



Caution

To comply with the Telcordia GR-1089 NEBS standard for electromagnetic compatibility and safety, connect the 2-port ISDN BRI card (VIC2-2BRI-NT/TE) only to intra-building or non-exposed wiring or cabling. The intrabuilding cable must be shielded and the shield must be grounded at both ends.

- Step 2** Connect one end of a straight-through RJ-45-to-RJ-45 cable to the RJ-45 port on the card. (See Figure 93.)

Figure 93 Connecting the 2-Port ISDN BRI Card

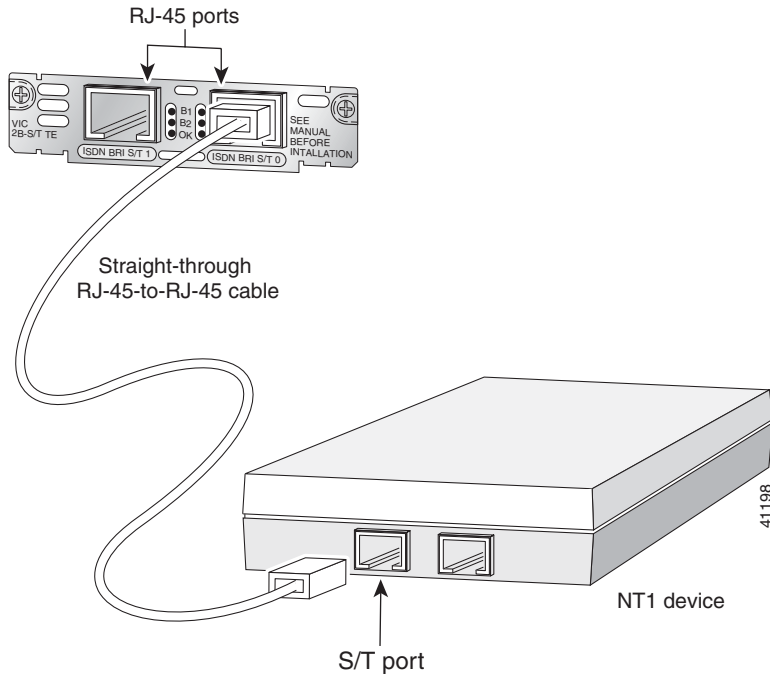

Note When the interface is configured as NT and is connecting to a TE device, the cable must have the transmit and receive pins swapped (crossover cable). See Table 25.

Table 25 Interface Pin Numbers and Functions

ISDN BRI NT/TE Card	NT Interface ¹	TE Interface ²
Pin 3/T+	Pin 3/R+	Pin 3/T+
Pin 4/R+	Pin 4/T+	Pin 4/R+
Pin 5/R-	Pin 5/T-	Pin 5/R-
Pin 6/T-	Pin 6/R-	Pin 6/T-

1. Use a straight-through cable for NT interfaces.
2. Use a crossover cable for TE interfaces.

- Step 3** Connect the other end of the cable to the RJ-45 wall outlet or other device.

ISDN BRI Interface Card LEDs

ISDN BRI voice interface cards have three LEDs, as listed in Table 26.

Table 26 *ISDN BRI Voice Interface Card LEDs*

LED	Meaning
B1	Call active on B1 channel
B2	Call active on B2 channel
OK	Interface is connected to an ISDN network

Analog Direct Inward Dial (DID) Interface Cards

A Direct Inward Dial (DID) voice interface provides DID service to extensions on a PBX. Figure 94 shows the VIC-2DID card, and Figure 95 shows the VIC-4FXS/DID card.



Caution

To comply with the Telcordia GR-1089 NEBS standard for electromagnetic compatibility and safety, connect the 4-port FXS/DID card (VIC-4FXS/DID) only to intra-building or non-exposed wiring or cabling. The intrabuilding cable must be shielded and the shield must be grounded at both ends.



Note

Each port on the 4-port FXS/DID VIC can be configured as either Foreign Exchange Station (FXS) or Direct Inward Dial (DID) when it is used with phones with a Ringer Equivalence Number (REN) load of 1 or less.

If the REN load on any port is greater than 1, all four ports must be configured as either FXS or DID. For information about using FXS with the 4-port FXS/DID VIC, see the “Foreign Exchange Station (FXS) Interface Cards” section on page 3.



Note

Cisco 2600XM series, Cisco 2691, Cisco 2800 series, Cisco 3600 series, Cisco 3700 series, and Cisco 3800 series routers support DID on the 4-port FXS/DID cards in Cisco IOS Release 12.3(14)T and later.

Figure 94 *2-Port Analog DID Voice Interface Card*

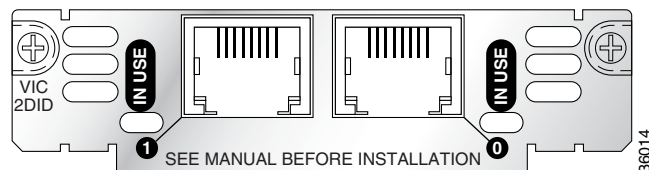
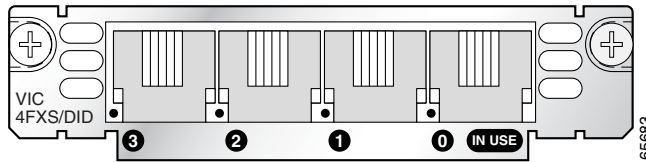

Figure 95 4-Port Analog FXS/DID Voice Interface Card



Connecting an Analog DID Interface Card

Use a standard straight-through RJ-11 modular telephone cable to connect the VIC-2DID or VIC-4FXS/DID interface card to a PSTN or PBX.

- Step 1** Install the grounding lug on the router. See the hardware installation guide for your router for detailed instructions. (Grounding on the Cisco 1700 series routers is done on the router chassis, and does not need a grounding lug.)



Caution

To comply with the Telcordia GR-1089 NEBS standard for electromagnetic compatibility and safety, connect the 4-port FXS/DID card (VIC-4FXS/DID) only to intra-building or non-exposed wiring or cabling. The intrabuilding cable must be shielded and the shield must be grounded at both ends.

- Step 2** Confirm that the router is still turned off.
- Step 3** Connect one end of the straight-through RJ-11 cable to an RJ-11 port on the card. (See Figure 96.)

Figure 96 Connecting an Analog DID Interface Card

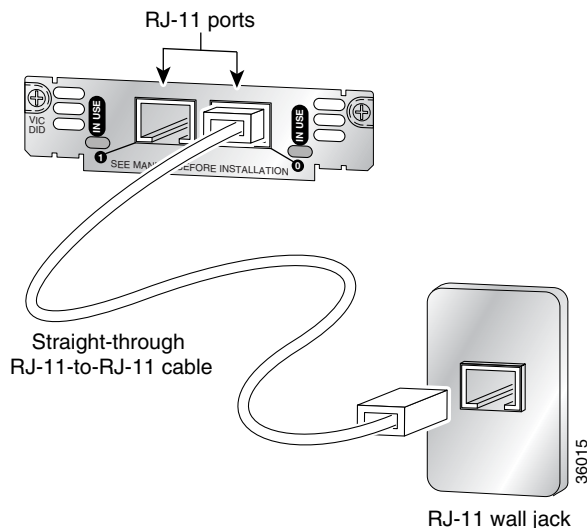

Caution

The VIC-2DID or the VIC-4FXS/DID interface cards may be damaged if connected to a standard PSTN line. Ensure that lines to the PSTN are provisioned for DID.

Step 4 Connect the other end of the cable to a telephone wall outlet or to a PBX.

Multiflex Trunk Interface Cards

Multiflex trunk interface cards support generic 1- or 2-port T1 or E1 trunk interfaces for voice, data, and integrated voice and data applications. These cards provide basic structured and unstructured service for T1 or E1 networks.

They can be used as trunk interfaces for voice and data services, as fractional $n \times 64$ -kbps service for WANs (Frame Relay or leased line), or for time-division multiplexing (TDM) drop-and-insert (voice and data integration) services.

Multiflex trunk interface cards provide voice and data access to the PSTN domain through TDM ports, and include an integrated channel service unit/data service unit (CSU/DSU).

Some 2-port multiflex trunk interface cards also support the drop-and-insert process, which adds data to a T1 or E1 data stream, or terminates data from a T1 or E1 data stream to other devices connected to the drop-and-insert equipment.



Caution

When both ports on a VWIC-2MFT-T1, VWIC-2MFT-E1, VWIC-2MFT-G703, or VWIC-2MFT-E1-DI interface card are configured as clock source line, then they must be set to the same clock source. If they are not set to the same clock source, timing slips can occur. Each port on the VWIC2-2MFT-T1/E1 and VWIC2-2MFT-G703 interface cards can be set to independent clock sources for data applications.

This section describes the following multiflex trunk interface cards:

- 1-port T1 multiflex trunk interface card (VWIC-1MFT-T1)
- 2-port T1 multiflex trunk interface card (VWIC-2MFT-T1)
- 1-port E1 multiflex trunk interface card (VWIC-1MFT-E1)
- 2-port E1 multiflex trunk interface card (VWIC-2MFT-E1)
- 1-port E1 multiflex trunk interface card with G.703 support (VWIC-1MFT-G703)
- 2-port E1 multiflex trunk interface card with G.703 support (VWIC-2MFT-G703)



Caution

To comply with the Telcordia GR-1089 NEBS standard for electromagnetic compatibility and safety, connect the 2-port E1 multiflex trunk interface card with G.703 support (VWIC-2MFT-G703) only to intra-building or non-exposed wiring or cabling. The intrabuilding cable must be shielded and the shield must be grounded at both ends.

- 2-port T1 multiflex trunk interface card with drop-and-insert capability (VWIC-2MFT-T1-DI)
- 2-port E1 multiflex trunk interface card with drop-and-insert capability (VWIC-2MFT-E1-DI)
- 1-port T1/E1 multiflex trunk interface card (VWIC2-1MFT-T1/E1)
- 2-port T1/E1 multiflex trunk interface card (VWIC2-2MFT-T1/E1)



Note

The VWIC2-1MFT-T1/E1 and VWIC2-2MFT-T1/E1 interface cards are configurable for T1 or E1 service and drop- and insert-capability.

- 1-port E1 multiflex trunk interface card with G.703 support (VWIC2-1MFT-G703)
- 2-port multiflex trunk interface card with G.703 support (VWIC2-2MFT-G703)



Note The VWIC-1MFT-G703, VWIC2-1MFT-G703, VWIC-2MFT-G703 and VWIC2-2MFT-G703 interface cards allow unstructured E1 traffic that conforms to the ITU-T G.703 standard.

The following multiflex trunk interface cards provide hardware echo cancellation features through an echo canceler expansion module, installed on the main board of the interface card:

- VWIC2-1MFT-T1/E1
- VWIC2-2MFT-T1/E1
- VWIC2-1MFT-G703
- VWIC2-2MFT-G703

The following expansion modules are available:

- 32-channel echo canceler module for multiflex trunk (EC-MFT-32)
- 64-channel echo canceler module for multiflex trunk (EC-MFT-64)

For information on echo canceler expansion module installation, see the *Installing Echo Canceler Expansion Modules on Cisco Interface Cards* document.

See Figure 97 for a sample 1-port multiflex trunk interface card, and Figure 98 for a sample 2-port multiflex trunk interface card.

Figure 97 1-Port T1/E1 Multiflex Trunk Interface Card Faceplate (VWIC-1MFT-T1)

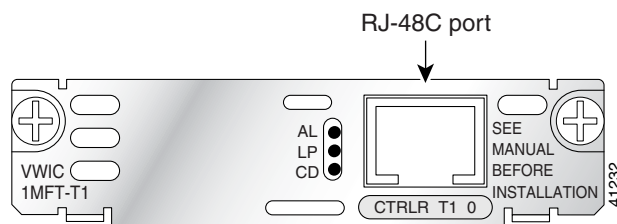
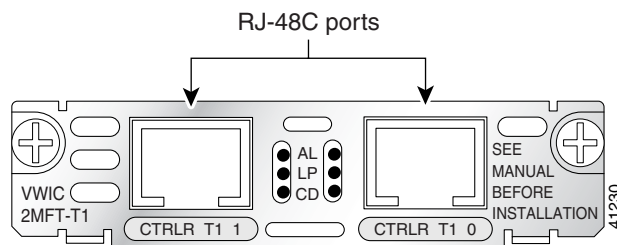

Figure 98 2-Port T1/E1 Multiflex Trunk Interface Card Faceplate (VWIC-2MFT-T1)



Multiflex Trunk Interface Card LEDs

Multiflex trunk interface cards have three LEDs, which are shown in Figure 97 and Figure 98 and are described in Table 27.

Table 27 Multiflex Trunk Interface Card LEDs

LED	Description	Color
LP LED	A loopback or line state is detected or is manually set by the user. This LED is off during normal operation.	Yellow
AL LED	A local or remote alarm state exists. This LED is off during normal operation.	Yellow
CD LED	A carrier has been detected, and the internal DSU/CSU in the interface card is communicating with another DSU/CSU. This LED is on during normal operation.	Green

Connecting a Multiflex Trunk Interface Card

For this connection, use the straight-through RJ-48C-to-RJ-48C cable that came with your card.



Note

Refer to the *Cisco Modular Access Router Specifications* for network-end connectors and pinouts of the cables connecting voice cards. Look under the type of interface card.

Confirm that the router is turned off.

- Step 5** Connect one end of the straight-through RJ-48C-to-RJ-48C cable to the T1 or E1 port on the card. (See Figure 99.)

Figure 99 Connecting a Multiflex Trunk Interface Card

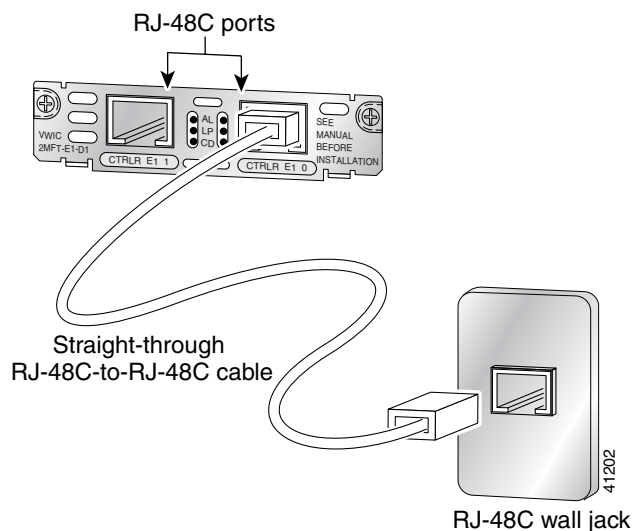

- Step 6** Connect the other end to the T1 or E1 wall jack (RJ-48C) at your site.
- Step 7** Turn on power to the router.

- Step 8** Check that the CD LED comes on, which means that the card's internal DSU/CSU is communicating with the DSU/CSU at the T1 or E1 service provider central office.

Centralized Automated Message Accounting Trunk Protocol Interface Cards

The Centralized Automated Message Accounting (CAMA) trunk protocol interface connects local calls to emergency services. The CAMA card provides the software features required to connect directly to the enhanced 911 (E911) network from the customer premises. It also provides direct connections to a Public Service Answering Point (PSAP) using analog CAMA trunks. The CAMA protocol provides in-band signaling.



Note

For the NM-HD-1V, NM-HD-2V, and NM-HD-2VE voice network modules, and for the Cisco 1751 and 1760 routers, CAMA is supported by the VIC2-2FXO interface card. The VIC-2CAMA card cannot be used with the NM-HD-1V, NM-HD-2V, or NM-HD-2VE voice network modules, or with the Cisco 1751 or Cisco 1760 routers.

CAMA Interface Cards

The 2-port CAMA card is illustrated in Figure 100.

Figure 100 V2-Port CAMA Card Front Panel (VIC-2CAMA)

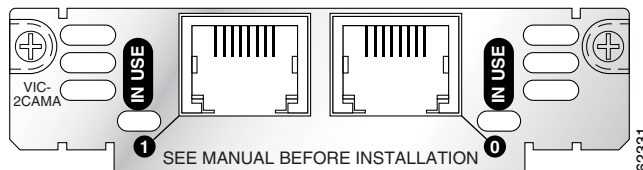

Connecting the CAMA Interface Card

Use a straight-through RJ-11 cable to connect the VIC-2CAMA voice interface card to the PSTN or PBX through a telephone wall outlet.



Note

Ports on this interface card are colored pink.

- Step 1** Confirm that the router is still turned off.
- Step 2** Connect one end of the straight-through RJ-11 cable to an RJ-11 port on the card. (See Figure 101.)

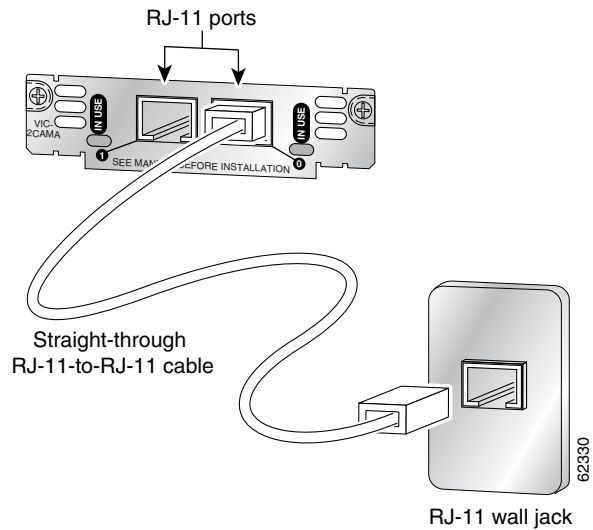
Figure 101 Connecting the 2-Port CAMA Card

Step 3 Connect the other end of the cable to the telephone wall outlet (RJ-11 port).

Related Documentation

Related documentation is available on Cisco.com or on the Product Documentation DVD. For more information, see the “Obtaining Documentation, Obtaining Support, and Security Guidelines” section on page 21.

Product Information and Supported Hardware and Software

- *Low Density Voice/Fax Network Modules for the Cisco 2600, 3600 and 3700 Series Routers*, data sheet
- *Understanding Direct Inward Dial (DID) Voice Interface Cards*, tech note
- *Voice Hardware Compatibility Matrix (Cisco 17xx, 26/36/37xx, VG200, Catalyst 4500/4000, Catalyst 6xxx)*, tech note
- *Cisco 4-Port High-Density FXS/DID Analog Voice Interface Card for the Cisco 1700 Series Modular Access Routers*, data sheet
- *Digital J1 Packet Voice Network Module*, data sheet
- *FXO, FXS, and E&M Voice Interface Card Support on Cisco 1700 Series Routers*
- *Understanding 1-Port and 2-Port E1 Multiflex Trunk Voice/WAN Interface Cards (VWICs)*, tech note
- *Cisco Digital 1-port and 2-port T1 Multi-Flex Voice WICs*, tech note
- *Cisco T1/E1 Multiflex Voice/WAN Interface Cards for the Cisco 1700 Series Modular Access Routers*, data sheet
- *Understanding E&M Voice Interface Cards*, tech note
- *Analog E&M Voice Signaling Overview*, tech note

- *Understanding and Troubleshooting Analog E & M Interface Types and Wiring Arrangements*, tech note
- *Understanding and Troubleshooting Analog E&M Start Dial Supervision Signaling*, tech note
- *E&M Cable Pinouts to Connect Cisco 1750/2600/3600 E&M VIC to Nortel PBX Option 11 E&M Trunk*, tech note
- *E&M Cable Pinouts Connecting Cisco 1750/2600/3600 E&M VIC to Lucent PBX G3R E&M Trunk*, tech note
- *Cisco Network Modules and Interface Cards Regulatory Compliance and Safety Information*
- *Analog DID for Cisco 2600 and Cisco 3600 Series Routers*, Cisco IOS Release 12.2(2)T feature module
- *Voice Software Enhancements for the Cisco 1750 and Cisco 1751 Routers*, configuration note
- *Configuring and Troubleshooting the VIC-2DID*, how-to
- *Analog DID for Cisco 2600 and Cisco 3600 Series Routers*, Cisco IOS Release 12.1(5)XM feature module
- *4-Port FXS/DID Voice Interface Card Support on the Cisco 1751 and Cisco 1760 Routers*, configuration note
- *Installing and Configuring the 1-Port Digital J1 Voice Interface Cards*
- *T1/E1 Multiflex VWIC Enhancements*, Cisco IOS Release 12.1(3)T feature module
- *G.703 Configuration for Multiflex Voice/WAN Interface Cards on Cisco 2600 and 3600 Series Routers*, Cisco IOS Release 12.1(1)T feature module
- *Configuring 1- and 2-Port T1/E1 Multiflex Voice/WAN Interface Cards on Cisco 2600 and 3600 Series Routers*, Cisco IOS Release 12.0(7)T feature module
- *Analog Centralized Automatic Message Accounting E911 Trunk*
- *Configuring 2-Port ISDN BRI Voice Interface Cards for the Cisco 1751 and Cisco 1760 Routers*, configuration note
- *Cisco IOS ISDN Voice Configuration Guide*, Release 12.3
- “VoIP Configuration” chapter in the *Cisco 1751 Router Software Configuration Guide*
- *Understanding One Stage and Two Stage Voice Dialing*, tech note
- *Structured CES Using Synchronous Clocking and PVCs in a Cisco 3600 Platform*, sample configuration
- *Unstructured CES with Synchronous Clocking and PVCs on a 3600 Platform*, tech note
- *Using Analog E&M Ports to Interface to Overhead Paging Systems*, sample configuration
- *Configuring Connection Trunk for VoIP Gateways*, sample configuration
- “Troubleshooting Analog Voice Interfaces to the IP Network” chapter of the *Cisco IOS Voice Troubleshooting and Monitoring Guide*
- *Configuring and Troubleshooting the VIC-2DID*, how-to
- *Ringling and Idle Voltages on Cisco FXS Interfaces*, tech note
- *Analog E&M Troubleshooting Guidelines (Cisco IOS Platforms)*, tech note
- *Understanding and Troubleshooting Analog E&M Start Dial Supervision Signaling*, tech note
- *Understanding and Troubleshooting Analog E & M Interface Types and Wiring Arrangements*, tech note

Obtaining Documentation, Obtaining Support, and Security Guidelines

For information on obtaining documentation, obtaining support, providing documentation feedback, security guidelines, and also recommended aliases and general Cisco documents, see the monthly *What's New in Cisco Product Documentation*, which also lists all new and revised Cisco technical documentation, at:

<http://www.cisco.com/en/US/docs/general/whatsnew/whatsnew.html>

CCVP, the Cisco Logo, and the Cisco Square Bridge logo are trademarks of Cisco Systems, Inc.; Changing the Way We Work, Live, Play, and Learn is a service mark of Cisco Systems, Inc.; and Access Registrar, Aironet, BPX, Catalyst, CCDA, CCDP, CCIE, CCIP, CCNA, CCNP, CCSP, Cisco, the Cisco Certified Internetwork Expert logo, Cisco IOS, Cisco Press, Cisco Systems, Cisco Systems Capital, the Cisco Systems logo, Cisco Unity, Enterprise/Solver, EtherChannel, EtherFast, EtherSwitch, Fast Step, Follow Me Browsing, FormShare, GigaDrive, HomeLink, Internet Quotient, IOS, iPhone, IP/TV, iQ Expertise, the iQ logo, iQ Net Readiness Scorecard, iQuick Study, LightStream, Linksys, MeetingPlace, MGX, Networking Academy, Network Registrar, *Packet*, PIX, ProConnect, RateMUX, ScriptShare, SlideCast, SMARTnet, StackWise, The Fastest Way to Increase Your Internet Quotient, and TransPath are registered trademarks of Cisco Systems, Inc. and/or its affiliates in the United States and certain other countries.

All other trademarks mentioned in this document or Website are the property of their respective owners. The use of the word partner does not imply a partnership relationship between Cisco and any other company. (0704R)

Any Internet Protocol (IP) addresses used in this document are not intended to be actual addresses. Any examples, command display output, and figures included in the document are shown for illustrative purposes only. Any use of actual IP addresses in illustrative content is unintentional and coincidental.

© 2007 Cisco Systems, Inc. All rights reserved.



Analog Modem WAN Interface Cards

Revised: 6/7/07, OL-12848-01

Overview

This document describes Cisco analog modem WICs and how to connect analog modem WICs to a network. It contains the following sections:

- Analog Modem WICs, page 1
- Analog Modem WIC LEDs, page 3
- Understanding Interface Numbering on Analog Modem WICs, page 4
- Connecting an Analog Modem WIC to a Network, page 4
- Related Documentation, page 5
- Obtaining Documentation, Obtaining Support, and Security Guidelines, page 6

For an overview of Cisco interface cards used for Cisco access routers see the *Cisco Interface Cards for Cisco Access Routers* document.

Analog Modem WICs

The analog modem WAN interface cards originate or terminate analog telephone transmissions through RJ-11 modular jacks.

There are four analog modem WICs:

- 1-port analog modem WAN interface card (WIC-1AM) (see Figure 102)
- 2-port analog modem WAN interface card (WIC-2AM) (see Figure 103)
- 1-port analog modem WAN interface card, version 2 (WIC-1AM-V2) (see Figure 104)
- 2-port analog modem WAN interface card, version 2 (WIC-2AM-V2) (see Figure 105)

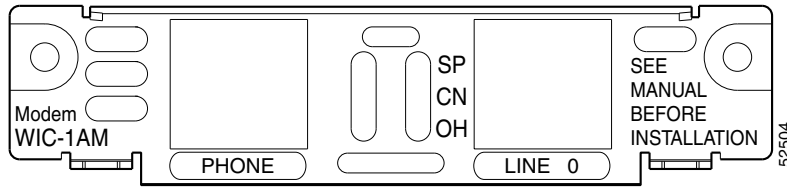
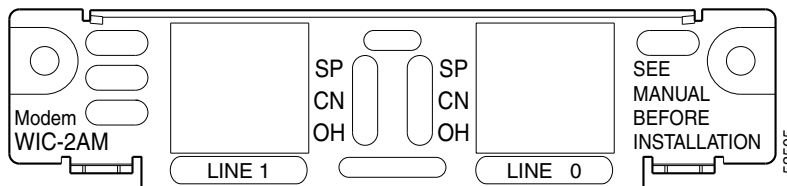
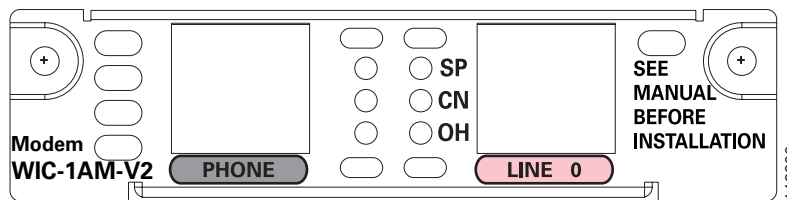
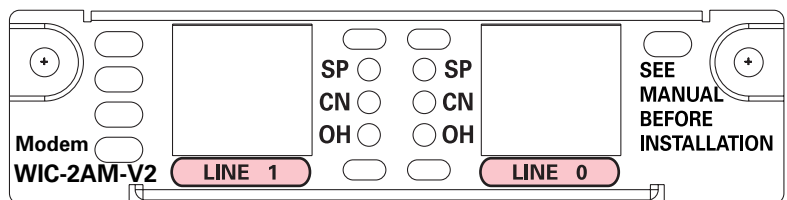
Figure 102 WIC-1AM Front Panel**Figure 103** WIC-2AM Front Panel**Figure 104** WIC-1AM-V2 Front Panel**Figure 105** WIC-2AM-V2 Front Panel

Restrictions

The following warning applies in Australia:



Warning

This equipment will be inoperable when main power fails.

The following warning applies in New Zealand:



Warning

This equipment does not fully meet Telecom's impedance requirements. Performance limitations may occur when used in conjunction with some parts of the network. Telecom will accept no responsibility should difficulties arise in such circumstances.

WIC-1AM and WIC-2AM Features

The WIC-1AM and WIC-2AM interface cards support the following protocols:

- All standard data rates from 300 bps to 33.6 kbps (V.34*bis*)
- V.42*bis* and MNP 5 data compression
- V.42, LAPM, and MNP 2 to 4 error correction
- V.90 up to 56 kbps
- MNP 10 for high performance under all line conditions
- MNP 10EC for high performance in analog cellular environments

WIC-1AM-V2 and WIC-2AM-V2 Features

You can upgrade WIC-1AM-V2 and WIC-2AM-V2 WAN interface card modem firmware, if a new image is released. For more information about configuring the WIC-1AM-V2 and WIC-2AM-V2 interface cards, and upgrading the modem firmware, see the *Cisco WIC-1AM-V2 and WIC-2AM-V2 Analog Modem WAN Interface Card* feature document.

The WIC-1AM-V2 and WIC-2AM-V2 interface cards support the following protocols:

- All standard data rates from 300 bps to 33.6 kbps (V.34*bis*)
- V.42*bis* and MNP 5 data compression
- V.42, LAPM, and MNP 2 to 4 error correction
- V.44 for a higher compression ratio over V.42*bis* compression technology.
- V.90 up to 56 kbps
- V.92 with quick-connect
- MNP 10 for high performance under all line conditions
- MNP 10EC for high performance in analog cellular environments

Analog Modem WIC LEDs

The analog modem WIC LEDs are shown in Figure 102 to Figure 105. The functions of the LEDs are described in Table 28.

Table 28 **Analog Modem WIC LEDs**

LED	Description
SP	Speed indication <ul style="list-style-type: none"> • On = High speed (V.56/V.90) • Off = Low speed (V.32/V.32b/V.34)
CN	Connect (carrier detect)
OH	Off-hook status

Understanding Interface Numbering on Analog Modem WICs

Cisco IOS software identifies each modem uniquely by its slot number and port number.

Some Cisco IOS configuration commands identify asynchronous ports by an interface number (or a line number, which is the same as the interface number). The interface number of a port on an 1-port or 2-port analog WAN interface card is related to the slot number where the card is installed and the number of the port in the card.

Slot numbering conventions for Cisco interface cards are explained in the “Interface Card Slots Available on Cisco Access Routers” section on page -8.

Ports in the 1- and 2-port analog modem WAN interface cards are numbered in the same pattern as slot numbers, beginning at 0 at the lower right and continuing from right to left.

The interface number of a port is determined in the following way:

$$\text{interface-number} = (32 \times \text{slot-number}) + \text{port-number} + 1$$

For example, modem port 1 in slot 1 corresponds to interface number $(32 \times 1) + 1 + 1 = 34$. This is also the line number for the port. Port 1 in slot 1 is always assigned interface number 34, regardless of what is in slot 0. If you move the card from slot 1 to a different slot, however, its interface numbers change.

Table 29 shows the range of interface numbers available for each type of analog modem card in each router slot. (Interface 0 is automatically assigned to the console.)

Table 29 1- and 2-Port Analog Modem WIC Numbering

Slot Number	Interface (1-Port WICs)	Interface (2-Port WICs)
0	1	1–2
1	33	33–34
2	65	65–66
3	97	97–98
4	129	129–130
5	161	161–162
6	193	193–194

Connecting an Analog Modem WIC to a Network

Use a straight-through RJ-11-to-RJ-11 cable (not included) to connect an analog modem WIC to a network.

Step 1 Turn off and confirm that the router is turned off.



Warning

To comply with the Telcordia GR-1089 NEBS standard for electromagnetic compatibility and safety, connect the WIC-1AM-V2 and WIC-2AM-V2 interface cards only to intra-building or unexposed wiring or cable. The intrabuilding cable must be shielded and the shield must be grounded at both ends. The intra-building port(s) of the equipment or subassembly must not be metallicly connected to interfaces that connect to the OSP or its wiring. These interfaces are designed for use as

intra-building interfaces only (Type 2 or Type 4 ports as described in GR-1089-CORE, Issue 4) and require isolation from the exposed OSP cabling. The addition of Primary Protectors is not sufficient protection in order to connect these interfaces metallically to OSP wiring.

- Step 2** Connect one end of a straight-through RJ-11-to-RJ-11 cable to the pink RJ-11 port labeled LINE on the analog modem WIC.
- Step 3** Connect the other end of the cable to a wall telephone outlet, as shown in Figure 106.

Figure 106 Connecting an Analog Modem WIC to a Wall Telephone Outlet

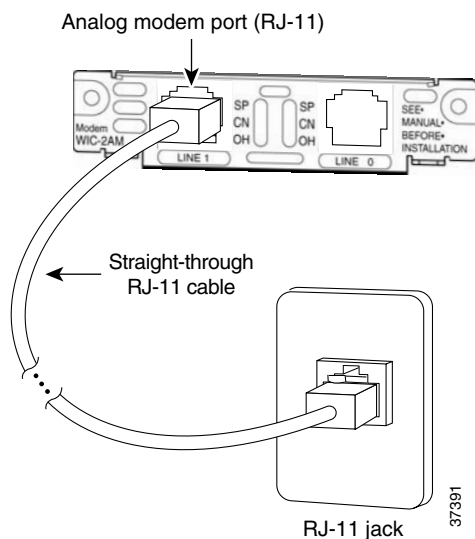

- Step 4** Depending on whether you have a 1-port or 2-port analog modem WIC:
- For 1-port analog modem WICs, you can connect an analog telephone to the RJ-11 port labeled PHONE. This allows the dialout line to be shared between the telephone and the modem.
 - For 2-port analog modem WICs repeat Step 2 and Step 3 to connect the second port to a network.
- Step 5** Turn on power to the router.

Related Documentation

Related documentation is available on Cisco.com. For more information, see the “Obtaining Documentation, Obtaining Support, and Security Guidelines” section on page 6.

- *1- and 2-Port V.90 Modem WICs for Cisco 2600 and Cisco 3600 Series Multiservice Platforms, Cisco IOS Release 12.2(8)T feature module*
- *AT Command Set and Register Summary for V.90 WIC-IAM and WIC-2AM Analog Modem WAN Interface Cards*
- *Analog Modem Interface Card Configuration Notes for Cisco 1700 Series Routers*
- *Cisco Network Modules and Interface Cards Regulatory Compliance and Safety Information*
- *Cisco WIC-IAM-V2 and WIC-2AM-V2 Analog Modem WAN Interface Card*
- *Modem-Router Connection Guide, tech note*

- *Recommended Modemcaps for Internal Digital and Analog Modems on Cisco Access Servers*, tech note
- *Understanding Analog Modem WAN Interface Cards (WIC-1AM or WIC-2AM)*, tech note
- *WAN Interface Card (WIC)/Platform Hardware Compatibility Matrix for 1600, 1700, 2600, 3600, and 3700 Series Routers*, tech note

Obtaining Documentation, Obtaining Support, and Security Guidelines

For information on obtaining documentation, obtaining support, providing documentation feedback, security guidelines, and also recommended aliases and general Cisco documents, see the monthly *What's New in Cisco Product Documentation*, which also lists all new and revised Cisco technical documentation, at:

<http://www.cisco.com/en/US/docs/general/whatsnew/whatsnew.html>

CCVP, the Cisco logo, and Welcome to the Human Network are trademarks of Cisco Systems, Inc.; Changing the Way We Work, Live, Play, and Learn is a service mark of Cisco Systems, Inc.; and Access Registrar, Aironet, Catalyst, CCDA, CCDP, CCIE, CCIP, CCNA, CCNP, CCSP, Cisco, the Cisco Certified Internetwork Expert logo, Cisco IOS, Cisco Press, Cisco Systems, Cisco Systems Capital, the Cisco Systems logo, Cisco Unity, Enterprise/Solver, EtherChannel, EtherFast, EtherSwitch, Fast Step, Follow Me Browsing, FormShare, GigaDrive, HomeLink, Internet Quotient, IOS, iPhone, IP/TV, iQ Expertise, the iQ logo, iQ Net Readiness Scorecard, iQuick Study, LightStream, Linksys, MeetingPlace, MGX, Networkers, Networking Academy, Network Registrar, PIX, ProConnect, ScriptShare, SMARTnet, StackWise, The Fastest Way to Increase Your Internet Quotient, and TransPath are registered trademarks of Cisco Systems, Inc. and/or its affiliates in the United States and certain other countries.

All other trademarks mentioned in this document or Website are the property of their respective owners. The use of the word partner does not imply a partnership relationship between Cisco and any other company. (0711R)

Any Internet Protocol (IP) addresses used in this document are not intended to be actual addresses. Any examples, command display output, and figures included in the document are shown for illustrative purposes only. Any use of actual IP addresses in illustrative content is unintentional and coincidental.

© 2007 Cisco Systems, Inc. All rights reserved.



LAN Interface Cards

Revised: 6/7/07, OL-12849-01

Overview

This document describes Cisco LAN interface cards and how to connect Cisco LAN interface cards to a network. It contains the following sections:

- WIC-4ESW Card, page 1
- WIC-1ENET Interface Card, page 4
- Supported Platforms, page 6
- Obtaining Documentation, Obtaining Support, and Security Guidelines, page 7

For an overview of Cisco interface cards used for Cisco access routers see the *Cisco Interface Cards for Cisco Access Routers* document.

WIC-4ESW Card

This section describes the 4-port 10/100BASE-TX Ethernet switch interface card (WIC-4ESW) and how to connect it to a network.

The following subsections are included:

- WIC-4ESW Interface Card Port Numbering, page 2
- WIC-4ESW Interface Card Processor Requirements, page 3
- WIC-4ESW Interface Card Supported Standards, page 3
- WIC-4ESW Interface Card Platform Limitations, page 3

The WIC-4ESW interface card is a Layer 2 Ethernet switch with Layer 3 routing capability. (Layer 3 routing is forwarded to the host, and is not actually performed at the switch.) The ports autosense the speed (10 Mbps or 100 Mbps) and duplex mode (full- or half-duplex) of the device to which it is connected and then operates at the same speed and in the same duplex mode.

**Caution**

To comply with the Telcordia GR-1089 NEBS standard for electromagnetic compatibility and safety, connect the 4-port 10/100BASE-TX Ethernet switch interface card (WIC-4ESW) only to intra-building or non-exposed wiring or cabling. The intrabuilding cable must be shielded and the shield must be grounded at both ends.

**Note**

The **show vtp status** command shows the maximum number of VLANs supported by the router. Although the router supports more VLANs, the WIC-4ESW interface card supports a maximum of 16 VLANs.

There are no new or modified commands for use with the WIC-4ESW interface card. All commands used with the switch are documented in the Cisco IOS command reference publications.

Figure 107 shows the WIC-4ESW interface card.

Figure 107 **WIC-4ESW Interface Card**

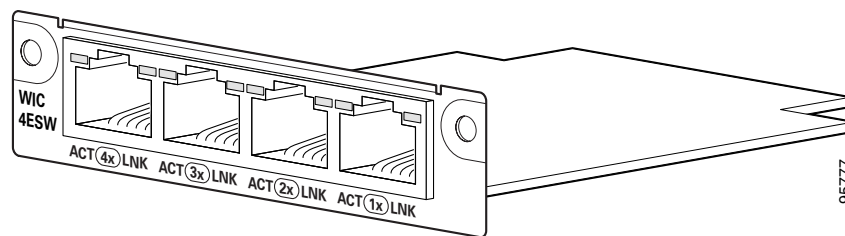

WIC-4ESW Interface Card LED

The LNK (physical layer link) LED is on when the Cisco IOS software recognizes the switch and the connection is up. The ACT (activity) LED indicates that data is being transmitted or received on the slot.

Additional information on the features of the card is provided in the *4-Port Ethernet Switch Configuration Notes for the Cisco 1700 Series Routers* document.

WIC-4ESW Interface Card Port Numbering

Port numbers identify the interfaces on the modules and interface cards installed in the router. Modules and interface cards are identified by interface type, slot number, a forward slash (/), and the port number. For example, F0/0 denotes the first Fast Ethernet port of the interface card, installed in slot 0 of the router.

The first port on the WIC-4ESW is always identified as “1.” For the Cisco 1721 router, the ports are referred to as FastEthernet1 to FastEthernet4, no matter in what slot the card is installed.

On the Cisco 1751 router and the Cisco 1760 router, the Fast Ethernet interfaces on WIC-4ESW are addressed as F<slot>/1 through F<slot>/4, depending in what slot the card is installed. (In this document, the ports will be referred to as F1 through F4.)

WIC-4ESW Interface Card Processor Requirements

The MPC 860 microprocessor (revision B5 or later) is required for using the Cisco WIC-4ESW card.

WIC-4ESW Interface Card Supported Standards

The WIC-4ESW interface card supports IEEE 802.3 Ethernet standards and 100BASE-T Category 3, 4, and 5 UTP cable distances up to 328 feet (100 meters).

The following standards are also supported:

- 802.1d
- 802.1p
- 802.1q

WIC-4ESW Interface Card Platform Limitations

The following features are *not supported* on the WIC-4ESW interface card:

- Virtual Local Area Network (VLAN) trunking protocols (server and client modes, and transparent mode v2)
- Spanning Tree Protocol (STP) backbone fast
- STP portfast Bridge Protocol Data Unit (BPDU) guard
- STP uplink fast
- STP Root Guard
- STP Unidirectional Link Detection (UDLD)
- Port security
- Protected Port
- 802.1x port-based authentication
- Storm control
- Switched Port Analyzer (SPAN)
- Internet Group Management Protocol (IGMP) Snooping
- 802.1P priority override
- MAC address table commands
- EtherChannel
- Enable or disable per port based on unknown unicast or multicast flooding
- Multicast groups
- IP multicast support
- Cisco Group Management Protocol (CGMP) client, CGMP fast-leave
- Dynamic access ports
- Dynamic trunk protocol
- Dynamic VLANs

- Voice VLANs
- General Attribute Registration Protocol (GARP), GARP Multicast Registration Protocol (GMRP), and GARP VLAN Registration Protocol (GVRP)
- Cisco Inter-Switch Link (ISL) tagging (the chip does not support ISL)
- Layer 3 on-board switching
- Monitoring of VLANs
- Multi-VLAN ports network port
- Shared STP instances
- VLAN-based SPAN
- VLAN Query Protocol (VQP)
- VTP pruning protocol
- Web-based management interface
- Remote Monitoring (RMON)

WIC-1ENET Interface Card

This section describes how to connect the Cisco 1-port Ethernet interface card supporting 10BASE-T Ethernet (WIC-1ENET), and contains the following sections:

- WIC-1ENET Interface Card LED, page 4
- WIC-1ENET Requirements, page 5
- WIC-1ENET Full-Duplex and Half-Duplex, page 6

The 1-port Ethernet interface card provides the router with additional Ethernet interfaces that can use the functionality of the Cisco IOS software with any type of external broadband modem, such as a cable modem, or xDSL modem.

Figure 108 shows the WIC-1ENET interface card.

Figure 108 **WIC-1ENET Interface Card**

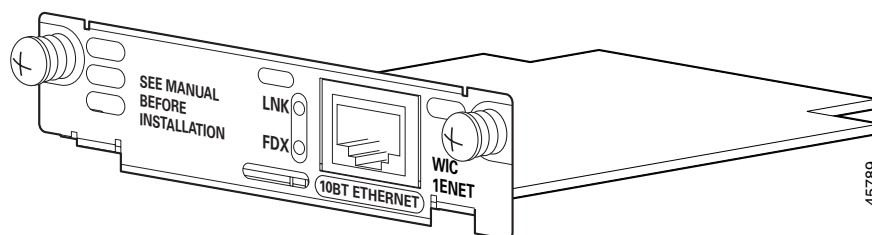

WIC-1ENET Interface Card LED

The LNK (physical layer link) LED is on when the Cisco IOS software recognizes the WIC-1ENET card and the connection is up. The FDX LED is on when the port is operating in full-duplex mode, and off when operating in half-duplex mode. Additionally, the Activity LED on the front of the router indicates that data is being transmitted or received on the slot.

WIC-1ENET Requirements

This section describes the requirements and supported standards for the WIC-1ENET card.

WIC-1ENET Memory Requirements

To run Cisco IOS images that support the WIC-1ENET card, the router must have a minimum amount of Flash memory and dynamic RAM (DRAM). For details on the memory requirements for each image, refer to *Release Notes for the Cisco 1700 Series Routers for Cisco IOS Release 12.2(4)T*.

WIC-1ENET Software Requirements

The WIC-1ENET card requires Cisco IOS Release 12.2(2)XJ or later if the card is installed in any WIC slot other than slot 0 or if more than one card is installed.

The card can be used with Cisco IOS Release 12.2(4)T, but the card must be installed in slot 0 and only one WIC-1ENET card can be installed in the router.

WIC-1ENET Interface Card Port Numbering

Port numbers identify the interfaces on the modules and interface cards installed in the router. Port numbers begin at 0 for each slot, and continue from right to left. Modules and interface cards are identified by interface type, slot number, a forward slash (/), and the port number. For example, E0/0 denotes the first Ethernet port of the interface card installed in slot 0 of the router.

On the Ethernet interface on the Cisco 1720 router is E0. The interface on the WIC-1ENET is addressed as E1.

On the Cisco 1750 router, the Ethernet interface on the router is E0/0. The interface on the WIC-1ENET is addressed as E<slot>/1.

WIC-1ENET Interface Card Router Processor Requirements

The MPC 860 microprocessor (revision B5 or later) in the Cisco 1700 series router is required for using the WIC-1ENET card.

The processor version information is displayed at bootup. You can also verify the processor revision by entering the **show version** command at the Cisco IOS command-line interface Router# prompt.

WIC-1ENET Supported Standards

The IEEE 802.3 Ethernet standards and 10BASE-T Category 3, 4, and 5 UTP cable distances up to 328 feet (100 meters) are supported.

WIC-1ENET Full-Duplex and Half-Duplex

The WIC-1ENET is set to half-duplex mode by default, and it does not autosense the mode of another device attached to the port. If you set the card to full-duplex operation, you must also set the device to which the port is attached to full-duplex mode.

Use the **full-duplex** command to put the Ethernet interface into full-duplex operation. The interface can be put into half-duplex mode by entering the **no full-duplex** command.

You can also use the **half-duplex** command to put the Ethernet interface into half-duplex operation, the default state of the Ethernet interface.

To verify the interface state, enter a **show interface** command as follows:

```
1750#show interface Ethernet 0

Ethernet0 is up, line protocol is up
  Hardware is PQUICC Ethernet, address is 0001.64ff.ef6a (bia 0001.64ff.ef6a)
  MTU 1500 bytes, BW 10000 Kbit, DLY 1000 usec,
    reliability 255/255, txload 1/255, rxload 1/255
  Encapsulation ARPA, loopback not set
  Keepalive set (10 sec)
  Half-duplex, 10BaseT
  ....
```

Supported Platforms

For a list of the platforms supported by a Cisco interface card refer to *Platform Support for Cisco Interface Cards*.

Finding Support Information for Platforms and Cisco IOS Software Images

Use Cisco Feature Navigator to find information about platform support and Cisco IOS software image support. Access Cisco Feature Navigator at <http://www.cisco.com/go/fn>. You must have an account on Cisco.com. If you do not have an account or have forgotten your username or password, click **Cancel** at the login dialog box and follow the instructions that appear.

Obtaining Documentation, Obtaining Support, and Security Guidelines

For information on obtaining documentation, obtaining support, providing documentation feedback, security guidelines, and also recommended aliases and general Cisco documents, see the monthly *What's New in Cisco Product Documentation*, which also lists all new and revised Cisco technical documentation, at:

<http://www.cisco.com/en/US/docs/general/whatsnew/whatsnew.html>

CCVP, the Cisco logo, and Welcome to the Human Network are trademarks of Cisco Systems, Inc.; Changing the Way We Work, Live, Play, and Learn is a service mark of Cisco Systems, Inc.; and Access Registrar, Aironet, Catalyst, CCDA, CCDP, CCIE, CCIP, CCNA, CCNP, CCSP, Cisco, the Cisco Certified Internetwork Expert logo, Cisco IOS, Cisco Press, Cisco Systems, Cisco Systems Capital, the Cisco Systems logo, Cisco Unity, Enterprise/Solver, EtherChannel, EtherFast, EtherSwitch, Fast Step, Follow Me Browsing, FormShare, GigaDrive, HomeLink, Internet Quotient, IOS, iPhone, IP/TV, iQ Expertise, the iQ logo, iQ Net Readiness Scorecard, iQuick Study, LightStream, Linksys, MeetingPlace, MGX, Networkers, Networking Academy, Network Registrar, PIX, ProConnect, ScriptShare, SMARTnet, StackWise, The Fastest Way to Increase Your Internet Quotient, and TransPath are registered trademarks of Cisco Systems, Inc. and/or its affiliates in the United States and certain other countries.

All other trademarks mentioned in this document or Website are the property of their respective owners. The use of the word partner does not imply a partnership relationship between Cisco and any other company. (0711R)

Any Internet Protocol (IP) addresses used in this document are not intended to be actual addresses. Any examples, command display output, and figures included in the document are shown for illustrative purposes only. Any use of actual IP addresses in illustrative content is unintentional and coincidental.

© 2007 Cisco Systems, Inc. All rights reserved.



10/100BASE-T Ethernet Switch High-Speed WAN Interface Cards

Revised: 6/7/07, OL-12850-01

Overview

This document describes Cisco 10/100BASE-T Ethernet switch high-speed WAN interface cards (HWICs) and how to connect Cisco 10/100BASE-T Ethernet HWICs to the network, and contains the following sections:

- Cisco 10/100BASE-T Ethernet Switch HWICs, page 1
- Installing a Daughter Card on the HWIC-4ESW Card, page 4
- Scenarios for Cisco 10/100BASE-T Ethernet Switch HWICs, page 6
- Connecting Cisco 10/100BASE-T Ethernet Switch HWICs to Your Network, page 6
- Stacking of Cisco 10/100BASE-T Ethernet Switch HWICs, page -7
- Related Documentation, page 7
- Obtaining Documentation, Obtaining Support, and Security Guidelines, page 8

For an overview of Cisco interface cards used for Cisco access routers see the *Cisco Interface Cards for Cisco Access Routers* document.

Cisco 10/100BASE-T Ethernet Switch HWICs

The Cisco 10/100BASE-T Ethernet switch HWIC is available as a 4-port single-wide HWIC (HWIC-4ESW), and as an (8+1)-port double-wide HWIC (HWIC-D-9ESW), providing Layer 2 switching for Cisco modular access routers.



Caution

To comply with the Telcordia GR-1089 NEBS standard for electromagnetic compatibility and safety, connect the 4-port single-wide HWIC (HWIC-4ESW), 4-port single-wide HWIC with PoE (HWIC-4ESW-POE), (8+1)-port double-wide HWIC (HWIC-D-9ESW), and (8+1)-port double-wide HWIC with PoE (HWIC-D-9ESW-POE) only to intra-building or non-exposed wiring or cabling. The intrabuilding cable must be shielded and the shield must be grounded at both ends.

**Note**

Cisco 10/100BASE-T Ethernet switch HWICs can be inserted into HWIC slots only. They are not designed to fit into WIC/VIC slots.

The Cisco 10/100BASE-T Ethernet switch HWIC provides Layer 2 switching for traffic between one port on the HWIC and any other port on the same HWIC. The HWIC also supports Layer 3 traffic to and from the HWIC and any of the other platform interfaces. Traffic between different VLANs on the switch is routed through the router platform.

Two Cisco 10/100BASE-T Ethernet switch HWICs can be stacked in a router chassis to provide expanded switching capability. See the “Stacking of Cisco 10/100BASE-T Ethernet Switch HWICs” section on page 7 for a detailed description.

Each version of the Cisco 10/100BASE-T Ethernet switch HWIC is capable of providing –48 volts of inline power through its ports. Inline power is used to provide power to an IP phone or to a wireless access point attached to a port.

**Note**

The HWIC-D-9ESW card provides inline power through only eight of its ports, ports 0 through 7. The ninth port (port 8) is intended to be a stacking port, and as such, does not support inline power.

To provide inline power, an HWIC must be provisioned with an optional daughter card that distributes inline power. Inline power is provided by a –48 volt power supply within the router. The daughter card distributes the –48 volt power to the ports of the HWIC.

**Note**

In order for the HWIC to distribute inline power, the router must be provisioned with an optional –48 volt power supply.

Cisco 10/100BASE-T Ethernet Switch HWIC LEDs

The Cisco 10/100BASE-T Ethernet switch HWIC uses two LEDs per port to indicate link status and inline power status. See Figure 109, Figure 110, and Table 30 for a description of these LEDs.

Figure 109 HWIC-4ESW Faceplate

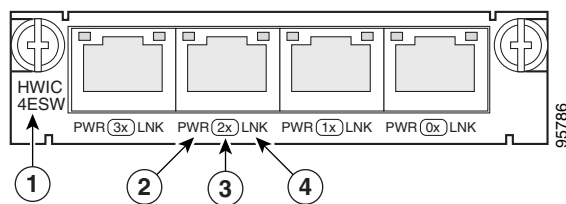

1	Product name	3	Port number
2	Inline power LED	4	Link LED

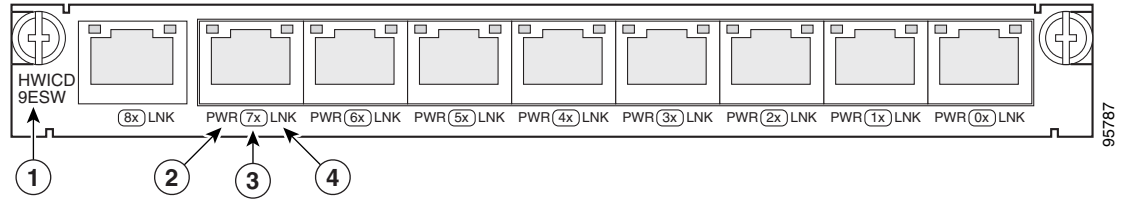
Figure 110 HWIC-D-9ESW Faceplate

1	Product name	3	Port number
2	Inline power LED	4	Link LED

Table 30 Cisco 10/100BASE-T Ethernet Switch HWIC LEDs

LED	Color	Definition	States
LNK	Green	Link Status	ON = Link pulses detected OFF = No link pulses detected
ILP	Green/amber	Inline Power Status	GREEN = Providing power to the device AMBER BLINKING = Power delivery fault or denial AMBER = Power administratively disabled OFF = No external device detected, or inline power option not installed.

Installing Inline Power Daughter Cards on Cisco 10/100BASE-T Ethernet Switch HWICs

This section describes the installation of inline power daughter cards on HWIC-4ESW and HWIC-D-9ESW Ethernet switch HWICs. Table 31 shows the inline power card mapping for the two HWICs.

Table 31 HWIC and Inline Power Card Mapping

HWIC Part Number	Inline Power Part Number
HWIC-4ESW	ILPM-4
HWIC-D-9ESW	ILPM-8



Note The inline power daughter cards are available separately as spares.



Note The inline power daughter cards are NOT interchangeable between the 4-port and the (8+1)-port HWICs.

Installing a Daughter Card on the HWIC-4ESW Card

To install an inline power daughter card on the HWIC-4ESW card, perform the following steps:

- Step 1** Install the three standoffs (included with the daughter card) on the HWIC motherboard, as shown in Figure 111, with the provided fastening screws. Tighten the screws firmly.

Figure 111 *Installing an Inline Power Card on the Cisco 10/100BASE-T Ethernet Switch HWIC-4ESW Card*

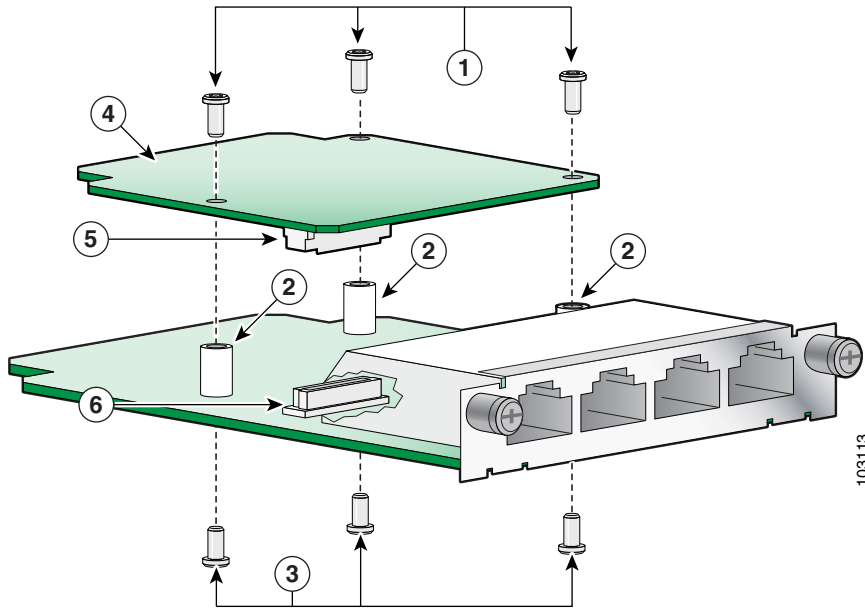

1	Fastening screws: daughter card to standoffs	4	Daughter card
2	Standoffs (3)	5	Daughter card connector
3	Fastening screws: standoffs to motherboard	6	Motherboard connector

- Step 2** Plug the daughter card connector into the motherboard connector, making sure that the standoffs align correctly underneath the mounting holes in the daughter card.
- Step 3** Connect the daughter card to the standoffs with the provided fastening screws. Tighten the screws firmly.

Installing a Daughter Card on the HWIC-D-9ESW Card

To install an inline power daughter card on the HWIC-D-9ESW card, perform the following steps:

- Step 1** Install the four standoffs (included with the daughterboard) onto the HWIC motherboard, as shown in Figure 112, with the provided fastening screws. Tighten the screws firmly.

Figure 112 *Installing an Inline Power Card on the Cisco 10/100BASE-T Ethernet Switch HWIC-D-9ESW Card*

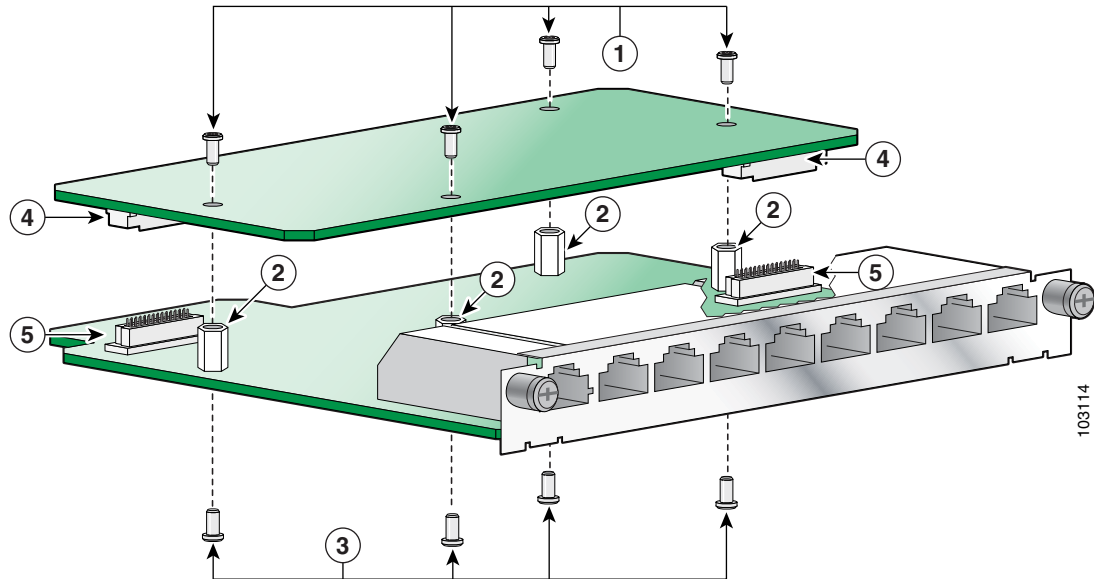

1	Fastening screws: daughter card to standoffs	4	Daughter card connectors
2	Standoffs	5	Motherboard connectors
3	Fastening screws: standoffs to motherboard		

- Step 2** Plug the daughter card connectors into the motherboard connectors, making sure that the standoffs align correctly underneath the mounting holes in the daughter card.
- Step 3** Connect the daughter card to the standoffs with the provided fastening screws. Tighten the screws firmly.

Verifying Daughter Card Installation

Perform the following steps to verify correct installation of the daughter card:

- Step 1** Install the HWIC into the router and power up the router.
- Step 2** Issue the **show power inline** command.

Step 3 Read the status of the –48 volt power supply and the ports that support inline power.

Scenarios for Cisco 10/100BASE-T Ethernet Switch HWICs

Cisco 10/100BASE-T Ethernet switch HWICs are designed for use in the following scenarios:

- Multiproduct WAN gateway routers for LANs
- Same-building or same-campus wiring closets to achieve high-speed connectivity for high-demand network segments



Tip

For more information on possible network configurations using the Cisco 10/100BASE-T Ethernet switch HWIC, see the *Configuration Guidelines for HWIC-4ESW and HWIC-D-9ESW Interface Cards* document.

Connecting Cisco 10/100BASE-T Ethernet Switch HWICs to Your Network

To connect the Cisco 10/100BASE-T Ethernet switch HWIC to the network, perform the following steps:

Step 1 Confirm that the router is powered down.

Step 2 Insert the Cisco 10/100BASE-T Ethernet switch HWIC into an HWIC slot on the platform.



Caution

To comply with the Telcordia GR-1089 NEBS standard for electromagnetic compatibility and safety, connect the 4-port single-wide HWIC (HWIC-4ESW), 4-port single-wide HWIC with PoE (HWIC-4ESW-POE), (8+1)-port double-wide HWIC (HWIC-D-9ESW), and (8+1)-port double-wide HWIC with PoE (HWIC-D-9ESW-POE) only to intra-building or non-exposed wiring or cabling. The intrabuilding cable must be shielded and the shield must be grounded at both ends.

Step 3 Using the appropriate cables, connect the card to your system.

- On the HWIC-4ESW card, all four ports support Auto-MDIX, so both straight-through and crossover cables can be used.
- On the HWIC-D-9ESW card, ports 0 through 7 support Auto-MDIX, so both straight-through and crossover cables may be used. Port 8 supports Auto-MDIX only when configured in Auto mode.

Step 4 Power up the router.

Stacking of Cisco 10/100BASE-T Ethernet Switch HWICs

Stacking is the connection of two Ethernet switch HWICs resident in the same chassis so that they behave as a single switch. Stacking is accomplished by daisy-chaining the two cards together with an external RJ-45 crossover cable that is connected to the specified stacking port on each switch.

When a chassis is populated with two Ethernet switch HWICs, the user must configure the cards to operate in stacked mode.

**Note**

There is no option to unstack two Ethernet switch HWICs. When two Ethernet switch HWICs are in the same chassis, they can operate only in stacked mode. If you configure the cards to operate unstacked, they will not operate correctly.

You must designate one port on each switch to be the stacking port. On the HWIC-4ESW card, this port is nominally the first port (port 0), although any port can be chosen. On the HWIC-D-9ESW card, this port is nominally the ninth port (port 8), although any port can be chosen. We recommend the use of port 8 as the stacking port, because it has been designed as an extra port on the HWIC-D-9ESW card and does not provide inline power.

**Note**

Only one port on an Ethernet switch HWIC can be configured as a stacking port.

All combinations of Ethernet switch HWICs may be stacked: two HWIC-D-9ESW cards, an HWIC-D-9ESW card with an HWIC-4ESW card, or two HWIC-4ESW cards.

See the *Configuration Guidelines for HWIC-4ESW and HWIC-D-9ESW Interface Cards* document for information on how to configure stacking ports.

Related Documentation

Related documentation is available on Cisco.com or on the Product Documentation DVD. For more information, see the “Obtaining Documentation, Obtaining Support, and Security Guidelines” section on page 8.

- *Cisco EtherSwitch 4- and 9-Port High-Speed WAN Interface Cards for Cisco 1800 (Modular), Cisco 2800, and Cisco 3800 Series Integrated Services Routers*, data sheet
- *Cisco EtherSwitch 4- and 9-Port High-Speed WAN Interface Cards for Cisco 1800 (Modular), Cisco 2800, and Cisco 3800 Series Integrated Services Routers*, Q&A
- *Cisco Network Modules and Interface Cards Regulatory Compliance and Safety Information*
- *Cisco HWIC-4ESW and HWIC-D-9ESW EtherSwitch Interface Cards*, Cisco IOS Release 12.3(8)T4 feature module

Obtaining Documentation, Obtaining Support, and Security Guidelines

For information on obtaining documentation, obtaining support, providing documentation feedback, security guidelines, and also recommended aliases and general Cisco documents, see the monthly *What's New in Cisco Product Documentation*, which also lists all new and revised Cisco technical documentation, at:

<http://www.cisco.com/en/US/docs/general/whatsnew/whatsnew.html>

CCVP, the Cisco logo, and Welcome to the Human Network are trademarks of Cisco Systems, Inc.; Changing the Way We Work, Live, Play, and Learn is a service mark of Cisco Systems, Inc.; and Access Registrar, Aironet, Catalyst, CCDA, CCDP, CCIE, CCIP, CCNA, CCNP, CCSP, Cisco, the Cisco Certified Internetwork Expert logo, Cisco IOS, Cisco Press, Cisco Systems, Cisco Systems Capital, the Cisco Systems logo, Cisco Unity, Enterprise/Solver, EtherChannel, EtherFast, EtherSwitch, Fast Step, Follow Me Browsing, FormShare, GigaDrive, HomeLink, Internet Quotient, IOS, iPhone, IP/TV, iQ Expertise, the iQ logo, iQ Net Readiness Scorecard, iQuick Study, LightStream, Linksys, MeetingPlace, MGX, Networkers, Networking Academy, Network Registrar, PIX, ProConnect, ScriptShare, SMARTnet, StackWise, The Fastest Way to Increase Your Internet Quotient, and TransPath are registered trademarks of Cisco Systems, Inc. and/or its affiliates in the United States and certain other countries.

All other trademarks mentioned in this document or Website are the property of their respective owners. The use of the word partner does not imply a partnership relationship between Cisco and any other company. (0711R)

Any Internet Protocol (IP) addresses used in this document are not intended to be actual addresses. Any examples, command display output, and figures included in the document are shown for illustrative purposes only. Any use of actual IP addresses in illustrative content is unintentional and coincidental.

© 2007 Cisco Systems, Inc. All rights reserved.



1- and 2-Port Fast Ethernet High-Speed WAN Interface Cards

Revised: 6/7/07, OL-12851-01

Overview

This document describes Cisco 1- and 2-Port Fast Ethernet high-speed WAN interface cards (HWICs) and how to connect Cisco 1- and 2-Port Fast Ethernet HWICs to the network, and contains the following sections:

- Cisco 1- and 2-Port Fast Ethernet HWICs, page 1
- Connecting Fast Ethernet HWICs to a Network, page 4
- Additional References, page 4
- Obtaining Documentation, Obtaining Support, and Security Guidelines, page 5

For an overview of Cisco interface cards used for Cisco access routers see the *Cisco Interface Cards for Cisco Access Routers* document.

Cisco 1- and 2-Port Fast Ethernet HWICs

The Cisco Fast Ethernet HWICs are single-wide interface cards, available as a 1-port HWIC (HWIC-1FE) and as a 2-port HWIC (HWIC-2FE), that provide Cisco modular and integrated services routers with additional line-rate Layer 3 routed ports. (See the “Fast Ethernet HWICs Supported Platforms” section on page 2.)

Fast Ethernet HWICs Standards

The Fast Ethernet HWICs are designed in accordance with IEEE 802.3 10BASE-T Ethernet and IEEE 802.3u 100BASE-TX Fast Ethernet standards.

The following IEEE standards are also supported:

- 802.1p
- 802.1u
- 802.1x

Fast Ethernet HWICs Restrictions

The following features are *not supported* on the Fast Ethernet HWICs:

- Cisco Interswitch Link (ISL) tagging
- Connectivity fault management (CFM)
- Flow control
- Online insertion and removal (OIR)

Fast Ethernet HWICs Supported Platforms

Install the Fast Ethernet HWICs in the following Cisco routers:

- Cisco 1841 integrated services router
- Cisco 2800 series integrated services routers
- Cisco 3800 series integrated services routers



Note

Insert Fast Ethernet HWICs into HWIC slots only. They do not fit into WIC/VIC slots.

Table 32 shows the maximum number of each type of HWIC that may be installed, the slot locations, and slot numbering for each platform.

Table 32 Supported Platforms for the Fast Ethernet HWICs

Chassis	HWIC-1FE	HWIC-2FE	Slot Locations	HWIC slots
Cisco 1841	1 may be installed	—	See Figure 7 on page 4	Slot 0 and slot 1 for HWIC-1FE only
Cisco 2801	1 to 2 may be installed	—	See Figure 9 on page 5	Slot 1 and slot 3 support HWICs
Cisco 2811	1 to 2 may be installed	—	See Figure 10 on page 6	Slot 0 to slot 3
Cisco 2821	1 to 2 may be installed	—	See Figure 10 on page 6	Slot 0 to slot 3
Cisco 2851	1 to 2 may be installed	—	See Figure 10 on page 6	Slot 0 to slot 3
Cisco 3825	1 to 4 may be installed	1 to 2 may be installed	See Figure 13 on page 7	Slot 0 to slot 3
Cisco 3845	1 to 4 may be installed	1 to 2 may be installed	See Figure 13 on page 7	Slot 0 to slot 3

Fast Ethernet HWICs Port Numbering

Port numbers identify the interfaces on the modules and interface cards installed in the router. Modules and interface cards are identified by three digits: slot number/subslot number/port number.

For example, HWIC port 0 in HWIC subslot 1 of router slot 0 is represented as:

```
interface FastEthernet 0/1/0
```

Fast Ethernet HWICs LEDs

The Fast Ethernet HWICs use three LEDs per port to indicate full- or half-duplex operation, collisions, speed, transmit/receive activity, and link status. Figure 113 and Figure 114 show the HWIC-1FE and HWIC-2FE faceplates, and Table 33 describes the functions of the LEDs.

Figure 113 HWIC-1FE Faceplate

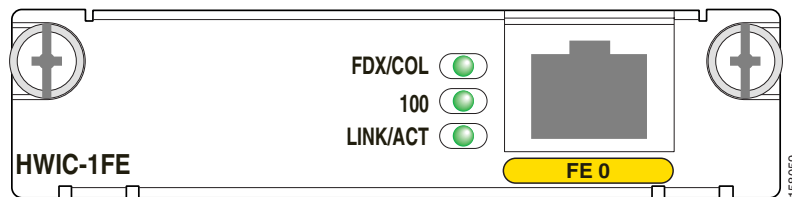

Figure 114 HWIC-2FE Faceplate

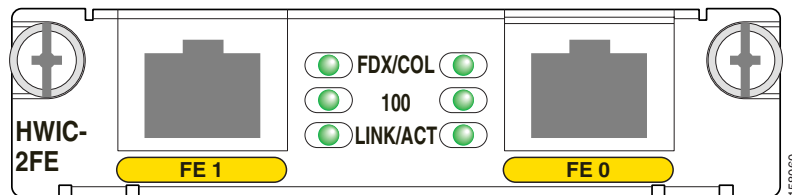

Table 33 Fast Ethernet HWIC LEDs

LED	Meaning	States
FDX/COL	Duplex/Collision	On = Full-duplex Off = Half-duplex Blinking = Collision activity
100	Speed	On = 100 Mbps Off = 10 Mbps
LNK/ACT	Link Status	On = Link pulses detected Off = No link pulses detected Blinking = Transmit or receive activity

Connecting Fast Ethernet HWICs to a Network

To connect a Fast Ethernet HWIC to the network, do the following procedure:

Step 1 Confirm that the router is powered down.



Warning

To comply with the Telcordia GR-1089 NEBS standard for electromagnetic compatibility and safety, connect the HWIC-1FE and HWIC-2FE interface cards only to intra-building or unexposed wiring or cable. The intrabuilding cable must be shielded and the shield must be grounded at both ends. The intra-building port(s) of the equipment or subassembly must not be metallically connected to interfaces that connect to the OSP or its wiring. These interfaces are designed for use as intra-building interfaces only (Type 2 or Type 4 ports as described in GR-1089-CORE, Issue 4) and require isolation from the exposed OSP cabling. The addition of Primary Protectors is not sufficient protection in order to connect these interfaces metallically to OSP wiring.

Step 2 Insert the Fast Ethernet HWIC into an HWIC slot on the router. (See Chapter , “Installing Cisco Interface Cards in Cisco Access Routers.”)



Note

Insert Fast Ethernet HWICs into HWIC slots only. They do not fit into WIC/VIC slots.

Step 3 Using the appropriate cables, connect the HWIC to your system.



Caution

To comply with the Telcordia GR-1089 NEBS standard for electromagnetic compatibility and safety, connect the 1-port HWIC (HWIC-1FE) and 2-port HWIC (HWIC-2FE) only to intrabuilding or nonexposed wiring or cabling.

- For 10BASE-T operation, Category 3, 4, or 5 UTP cable may be used, for distances of up to 328 feet (100 meters).
- For 100BASE-TX operation, Category 5 UTP cable is required, for distances of up to 328 feet (100 meters).
- The HWICs support Auto-MDIX, so either straight-through or crossover cable can be used.

Step 4 Power up the router.

Additional References

For additional information, see the following documents and resources.

Related Topic	Document Title
Regulatory compliance and safety information	<i>Cisco Network Modules and Interface Cards Regulatory Compliance and Safety Information</i>

Related Topic	Document Title
Cisco IOS software website and reference documentation	<i>Cisco IOS Software</i> http://www.cisco.com/en/US/products/sw/iosswrel/tsd_products_support_category_home.html
Technical documentation, including feedback and assistance	<i>What's New in Cisco Product Documentation</i> (including monthly listings of new and revised documents) at http://www.cisco.com/univercd/cc/td/doc/abtunicd/136957.htm

Obtaining Documentation, Obtaining Support, and Security Guidelines

For information on obtaining documentation, obtaining support, providing documentation feedback, security guidelines, and also recommended aliases and general Cisco documents, see the monthly *What's New in Cisco Product Documentation*, which also lists all new and revised Cisco technical documentation, at:

<http://www.cisco.com/en/US/docs/general/whatsnew/whatsnew.html>

CCVP, the Cisco logo, and Welcome to the Human Network are trademarks of Cisco Systems, Inc.; Changing the Way We Work, Live, Play, and Learn is a service mark of Cisco Systems, Inc.; and Access Registrar, Aironet, Catalyst, CCDA, CCDP, CCIE, CCIP, CCNA, CCNP, CCSP, Cisco, the Cisco Certified Internetwork Expert logo, Cisco IOS, Cisco Press, Cisco Systems, Cisco Systems Capital, the Cisco Systems logo, Cisco Unity, Enterprise/Solver, EtherChannel, EtherFast, EtherSwitch, Fast Step, Follow Me Browsing, FormShare, GigaDrive, HomeLink, Internet Quotient, IOS, iPhone, IP/TV, iQ Expertise, the iQ logo, iQ Net Readiness Scorecard, iQuick Study, LightStream, Linksys, MeetingPlace, MGX, Networkers, Networking Academy, Network Registrar, PIX, ProConnect, ScriptShare, SMARTnet, StackWise, The Fastest Way to Increase Your Internet Quotient, and TransPath are registered trademarks of Cisco Systems, Inc. and/or its affiliates in the United States and certain other countries.

All other trademarks mentioned in this document or Website are the property of their respective owners. The use of the word partner does not imply a partnership relationship between Cisco and any other company. (0711R)

Any Internet Protocol (IP) addresses used in this document are not intended to be actual addresses. Any examples, command display output, and figures included in the document are shown for illustrative purposes only. Any use of actual IP addresses in illustrative content is unintentional and coincidental.

© 2007 Cisco Systems, Inc. All rights reserved.



Gigabit Ethernet High-Speed WAN Interface Cards

Revised: 6/7/07, OL-12852-01

Overview

This document describes Cisco Gigabit Ethernet high-speed WAN interface cards (HWICs) and how to connect a Cisco Gigabit Ethernet HWIC to the network, and contains the following sections:

- Cisco Gigabit Ethernet High-Speed WAN Interface Cards, page 1
- Installing Small Form-Factor Pluggable Modules into Cisco Gigabit Ethernet High-Speed WAN Interface Cards, page 4
- Removing Small Form-Factor Pluggable Modules from Cisco Gigabit Ethernet High-Speed WAN Interface Cards, page 5
- Cabling for Small Form-Factor Pluggable Modules, page 6
- Connecting Cisco Gigabit Ethernet High-Speed WAN Interface Cards to the Network, page 7
- Related Documentation, page 8
- Obtaining Documentation, Obtaining Support, and Security Guidelines, page 9

For an overview of Cisco interface cards used for Cisco access routers see the *Cisco Interface Cards for Cisco Access Routers* document.

Cisco Gigabit Ethernet High-Speed WAN Interface Cards

The Cisco Gigabit Ethernet high-speed WAN interface card (HWIC-1GE-SFP) is a high-speed interface card providing copper and optical Gigabit Ethernet connectivity for Cisco modular access routers.

The Cisco Gigabit Ethernet high-speed WAN interface card provides copper and optical Gigabit Ethernet connectivity through a small form-factor pluggable module (SFP), which is inserted into the interface card. (See the “Installing Small Form-Factor Pluggable Modules into Cisco Gigabit Ethernet High-Speed WAN Interface Cards” section on page 4.)

SFPs can be installed or removed without powering down the router and interface card.

**Caution**

To comply with the Telcordia GR-1089 NEBS standard for electromagnetic compatibility and safety, connect the Gigabit Ethernet high-speed WAN interface card (HWIC-1GE-SFP) only to intra-building or non-exposed wiring or cabling. The intrabuilding cable must be shielded and the shield must be grounded at both ends.

**Note**

The Cisco Gigabit Ethernet high-speed WAN interface card itself is not hot-swappable. Removal or insertion of the Cisco Gigabit Ethernet high-speed WAN interface card requires powering down the router.

The Cisco Gigabit Ethernet high-speed WAN interface card supports the SFPs shown in Table 34.

Table 34 *SFPs Supported on the Cisco Gigabit Ethernet High-Speed WAN Interface Card (HWIC-1GE-SFP)*

GE SFP Transceiver Type	Cisco Part Number	Wavelength	Maximum Distance
1000BASE-T	GLC-T=	n/a	100 m
1000BASE-SX	GLC-SX-MM=	850 nm	500 m
1000BASE-LX/LH	GLC-LH-SM=	1310 nm	10 km
1000BASE-ZX	GLC-ZX-SM=	1550 nm	80 km
1000BASE-CWDM	CWDM-SFP-1470=	1470 nm	100 km
	CWDM-SFP-1490=	1490 nm	
	CWDM-SFP-1510=	1510 nm	
	CWDM-SFP-1530=	1530 nm	
	CWDM-SFP-1550=	1550 nm	
	CWDM-SFP-1570=	1570 nm	
	CWDM-SFP-1590=	1590 nm	
	CWDM-SFP-1610=	1610 nm	

**Note**

Only Cisco-certified SFPs are supported on the Cisco Gigabit Ethernet high-speed WAN interface card.

**Tip**

When switching from one type of SFP to another, connection problems, including connection failure, may result. Use the **show controller** command at the Cisco IOS command-line interface (CLI) to determine whether you are using an SFP certified by Cisco.

Different SFPs have different cabling requirements; see the “Cabling for Small Form-Factor Pluggable Modules” section on page 6 for more information on SFP cabling.

Laser Safety Guidelines

Optical SFPs use a small laser to generate the fiber-optic signal. Keep the optical transmit and receive ports covered whenever a cable is not connected to the port.

The interface card faceplate carries a Class 1 laser warning label. (See Figure 115.)

Figure 115 Class 1 Laser Warning Label

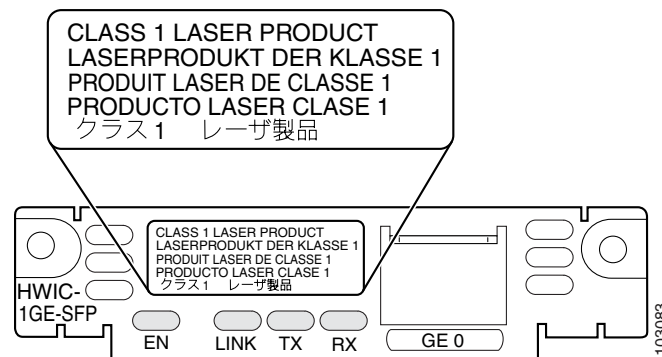

Warning

Because invisible laser radiation may be emitted from the aperture of the port when no fiber cable is connected, avoid exposure to laser radiation and do not stare into open apertures. Statement 125



Warning

Ultimate disposal of this product should be handled according to all national laws and regulations. Statement 1040

Cisco Gigabit Ethernet High-Speed WAN Interface Card LEDs

The Cisco Gigabit Ethernet high-speed WAN interface card uses LEDs to indicate card status and activity. (See Figure 116.)

Figure 116 Cisco Gigabit Ethernet High-Speed WAN Interface Card Faceplate (HWIC-1GE-SFP)

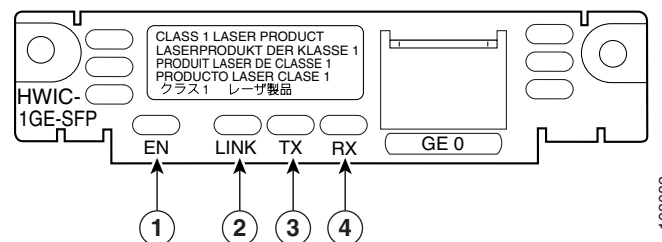

1	EN: When green, indicates that the interface card is available to the router.	2	LINK: When green, indicates that the connection is available to the router.
3	TX: When green, indicates that the interface is transmitting data to the network.	4	RX: When green, indicates that the interface is receiving data from the network.

Installing Small Form-Factor Pluggable Modules into Cisco Gigabit Ethernet High-Speed WAN Interface Cards

Small form-factor pluggable modules (SFPs) are hot-swappable Ethernet interfaces that can be installed directly into the Cisco Gigabit Ethernet high-speed WAN interface card. See Table 34 for SFPs supported on the Cisco Gigabit Ethernet high-speed WAN interface card.

To install an SFP into the Cisco Gigabit Ethernet high-speed WAN interface card, perform the following steps:

- Step 1** Install the interface card in the router. (See Chapter , “Installing Cisco Interface Cards in Cisco Access Routers.”)



Warning

Because invisible laser radiation may be emitted from the aperture of the port when no fiber cable is connected, avoid exposure to laser radiation and do not stare into open apertures. Statement 125

- Step 2** Slide the SFP into the housing on the interface card until it is locked into position. (See Figure 117.) The SFP is designed to prevent improper insertion.



Tip

If the SFP uses a bale-clasp latch (see Figure 117 and Figure 118), the bale-clasp handle should be on top of the SFP in the closed position for proper seating of the SFP module.

Figure 117 Installing an SFP on the Cisco Gigabit Ethernet High-Speed WAN Interface Card

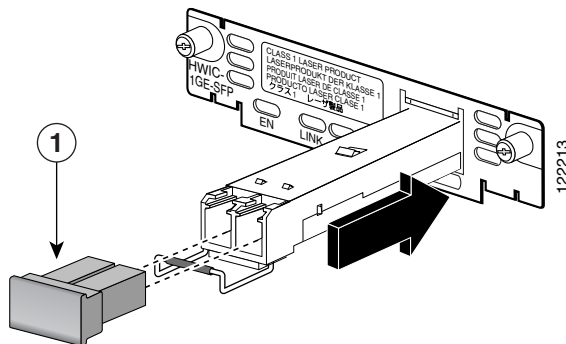

- 1** Optical port plug



Caution

Do not remove the optical port plugs used on the SFP until you are ready to connect cabling to the interface card.



Caution

To comply with the Telcordia GR-1089 NEBS standard for electromagnetic compatibility and safety, connect the Gigabit Ethernet high-speed WAN interface card (HWIC-1GE-SFP) only to intra-building or non-exposed wiring or cabling. The intrabuilding cable must be shielded and the shield must be grounded at both ends.

- Step 3** Connect the interface card to the network. (See the “Connecting Cisco Gigabit Ethernet High-Speed WAN Interface Cards to the Network” section on page 7.)

Removing Small Form-Factor Pluggable Modules from Cisco Gigabit Ethernet High-Speed WAN Interface Cards

This section describes a generic removal procedure. Small form-factor pluggable modules (SFPs) use various latch designs (see Figure 118) to secure the module in the SFP port.



Note

Latch designs are not linked to SFP model or technology type; for information on the SFP technology type and model, see the label on the top or side of the SFP.

Removing SFPs from Cisco Gigabit Ethernet High-Speed WAN Interface Cards

To remove an SFP from a Cisco Gigabit Ethernet high-speed WAN interface card, perform the following steps:

- Step 1** Disconnect all cables from the SFP.



Warning

Because invisible laser radiation may be emitted from the aperture of the port when no fiber cable is connected, avoid exposure to laser radiation and do not stare into open apertures. Statement 125



Caution

The latching mechanism used on many SFPs locks the SFP into place whenever cables are connected. Do not pull on the cabling in an attempt to remove the SFP.

- Step 2** Disconnect the SFP latch (see Figure 118).

Figure 118 Disconnecting SFP Latch Mechanisms

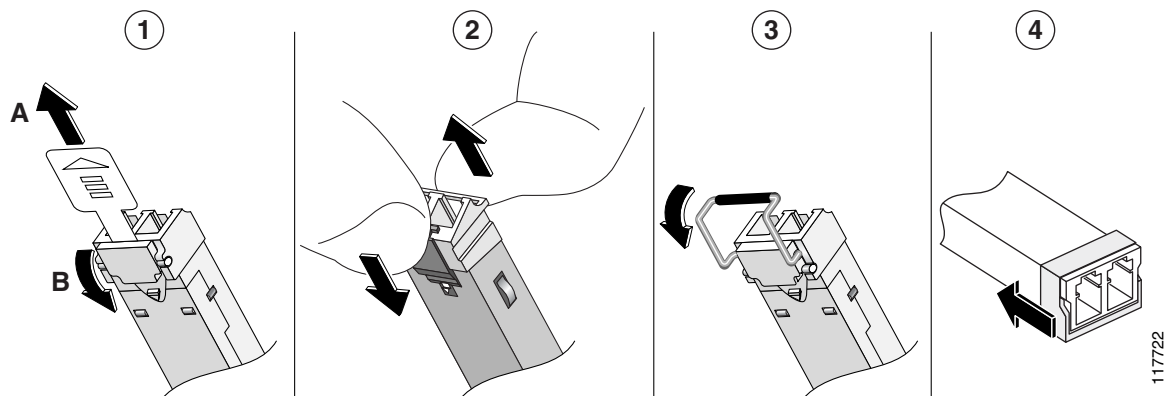

1	Sliding latch	2	Swing and slide latch
3	Bale-clasp latch	4	Plastic collar latch

**Tip**

Use a pen, screwdriver, or other small, straight tool to gently release the bale-clasp handle if you cannot reach it with your fingers.

Step 3 Grasp the SFP on both sides and remove it from the interface card.

Cabling for Small Form-Factor Pluggable Modules

Cisco Gigabit Ethernet high-speed WAN interface cards connect to the network through various supported small form-factor pluggable modules (SFPs). Cabling requirements vary by SFP. See the “Cabling for Small Form-Factor Pluggable Modules” section on page 6.

For information on cabling requirements for various small form-factor pluggable modules (SFPs) supported by the Cisco Gigabit Ethernet high-speed WAN interface card, see Table 35.

Table 35 Cabling Requirements for Gigabit Ethernet Small Form-Factor Pluggable Modules

GE SFP Transceiver Type	Cisco Part Number	Maximum Distance	Cabling Required	Connector Type
1000BASE-T	GLC-T=	100 m	Category 5, 5e, 6	RJ-45
1000BASE-SX	GLC-SX-MM=	300 m	62.5/125 micrometer MMF ¹	LC connector
		500 m	50/125 micrometer MMF	
1000BASE-LX/LH	GLC-LH-SM=	550 m	50/125 micrometer or 62.5/125 micrometer MMF	LC connector
		10 km	9/125 micrometer SMF ²	
1000BASE-ZX	GLC-ZX-SM=	80 km	9/125 micrometer SMF	LC connector
1000BASE-CWDM	CWDM-SFP-1470= CWDM-SFP-1490= CWDM-SFP-1510= CWDM-SFP-1530= CWDM-SFP-1550= CWDM-SFP-1590= CWDM-SFP-1610=	100 km	9/125 micrometer SMF	LC connector

1. MMF = multimode fiber

2. SMF = singlemode fiber

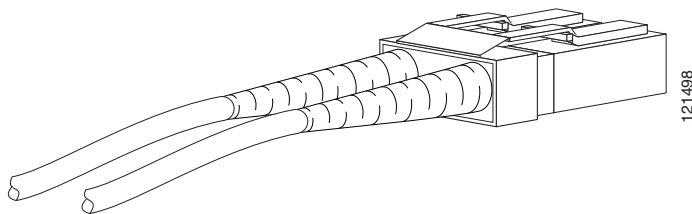
Figure 119 LC Connector**Note**

Coarse wavelength-division multiplexing (CWDM) SFP transceivers are color-coded based on wavelength: gray (1470), violet (1490), blue (1510), green (1530), yellow (1550), orange (1570), red (1590), and brown (1610).

Cisco Gigabit Ethernet high-speed WAN interface cards are designed for use in the following network design scenarios:

- In metropolitan-area network (MAN) backbones for low-cost, high-speed, and long-distance connectivity
- In multiprotocol WAN gateway routers for LANs
- In same-building or same-campus wiring closets to achieve high-speed connectivity for high-demand network segments

**Tip**

For more information on possible network configurations using the Cisco Gigabit Ethernet high-speed WAN interface card, see Cisco product documentation.

Connecting Cisco Gigabit Ethernet High-Speed WAN Interface Cards to the Network

To connect the Cisco Gigabit Ethernet high-speed WAN interface card to the network, perform the following steps:

Step 1 Confirm successful insertion of the SFP.

**Warning**

Because invisible laser radiation may be emitted from the aperture of the port when no fiber cable is connected, avoid exposure to laser radiation and do not stare into open apertures. Statement 125

Step 2 Confirm that the router is powered down.

Step 3 Remove optical port plugs from the installed SFP.

Step 4 Use the appropriate cable (see Table 35) to connect to the installed SFP.

**Note**

For short distances or loopbacks, network installations using 1000BASE-CWDM and 1000BASE-ZX SFPs may require 15-dBm attenuators to avoid over-powering the connection. Calculate the power budget for the connection to determine which attenuator to use.

Obtaining Documentation, Obtaining Support, and Security Guidelines

For information on obtaining documentation, obtaining support, providing documentation feedback, security guidelines, and also recommended aliases and general Cisco documents, see the monthly *What's New in Cisco Product Documentation*, which also lists all new and revised Cisco technical documentation, at:

<http://www.cisco.com/en/US/docs/general/whatsnew/whatsnew.html>

CCVP, the Cisco logo, and Welcome to the Human Network are trademarks of Cisco Systems, Inc.; Changing the Way We Work, Live, Play, and Learn is a service mark of Cisco Systems, Inc.; and Access Registrar, Aironet, Catalyst, CCDA, CCDP, CCIE, CCIP, CCNA, CCNP, CCSP, Cisco, the Cisco Certified Internetwork Expert logo, Cisco IOS, Cisco Press, Cisco Systems, Cisco Systems Capital, the Cisco Systems logo, Cisco Unity, Enterprise/Solver, EtherChannel, EtherFast, EtherSwitch, Fast Step, Follow Me Browsing, FormShare, GigaDrive, HomeLink, Internet Quotient, IOS, iPhone, IP/TV, iQ Expertise, the iQ logo, iQ Net Readiness Scorecard, iQuick Study, LightStream, Linksys, MeetingPlace, MGX, Networkers, Networking Academy, Network Registrar, PIX, ProConnect, ScriptShare, SMARTnet, StackWise, The Fastest Way to Increase Your Internet Quotient, and TransPath are registered trademarks of Cisco Systems, Inc. and/or its affiliates in the United States and certain other countries.

All other trademarks mentioned in this document or Website are the property of their respective owners. The use of the word partner does not imply a partnership relationship between Cisco and any other company. (0711R)

Any Internet Protocol (IP) addresses used in this document are not intended to be actual addresses. Any examples, command display output, and figures included in the document are shown for illustrative purposes only. Any use of actual IP addresses in illustrative content is unintentional and coincidental.

© 2007 Cisco Systems, Inc. All rights reserved.



REVIEW DRAFT - CISCO CONFIDENTIAL

3G Wireless WAN Interface Cards

Revised: 6/7/07, OL-12853-01

Overview

This document describes third-generation (3G) wireless high-speed WAN interface cards (HWICs) and how to connect the 3G wireless HWICs to a cellular network, and contains the following sections:

- 3G Wireless WAN HWIC Overview, page 1
- HWIC-3G-GSM, page 2
- HWIC-3G-CDMA, page 4
- Prerequisites, page 6
- Restrictions, page 6
- Installing a SIM Card in the HWIC-3G-GSM, page 7
- 3G Wireless HWIC LEDs, page 10
- Connecting an Antenna with the 3G Wireless WAN HWIC, page 10
- Related Documentation, page 15
- Obtaining Documentation, Obtaining Support, and Security Guidelines, page 16

For an overview of Cisco interface cards used for Cisco access routers see the *Cisco Interface Cards for Cisco Access Routers* document.

3G Wireless WAN HWIC Overview

The 3G wireless HWIC is a multiband, multiservice WAN card. Its primary application is WAN connectivity as a backup datalink for critical data applications and as a primary WAN connection. It supports the Cisco 1800 series, the Cisco 2800 series and the Cisco 3800 series integrated service routers (Cisco ISRs).

The 3G wireless WAN HWIC houses one cellular modem for connection to a wireless WAN. There are two different cellular modem (wireless WAN) HWIC versions based on 3G cellular technologies:

- HWIC-3G-GSM
- HWIC-3G-CDMA

REVIEW DRAFT – CISCO CONFIDENTIAL

For regulatory information about the 3G wireless WAN HWIC and supported antennas, see the *Cisco Network Modules and Interface Cards Regulatory Compliance and Safety Information*.

HWIC-3G-GSM

The GSM version supports the following services:

- General Packet Radio Services (GPRS)
- Enhanced Data Rates for GSM Evolution (EDGE)
- Universal Mobile Telecommunication System (UMTS)
- High-Speed Downlink Packet Access (HSDPA)

It supports multiple bands on the multiple services for use in different parts of the world:

- 850/900/1800/1900 MHz for GPRS and EDGE services
- 850/1900/2100 MHz for UMTS and HSDPA services

HWIC-3G-GSM is the Cisco part number for which the interface card is configured.

Figure 121 shows the front panel view of a 3G wireless WAN HWIC.

Figure 121 HWIC-3G-GSM Front Panel

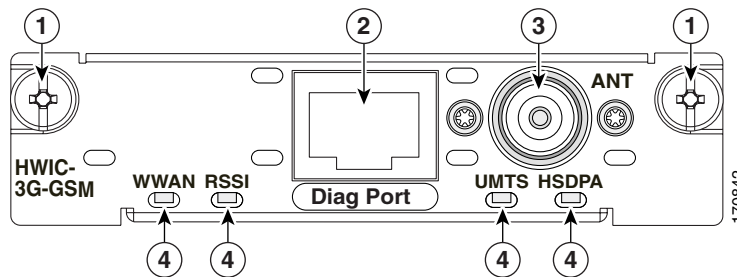

1	Mounting Screws	3	Antenna Connector
2	Diagnostic Port	4	LEDs

REVIEW DRAFT – CISCO CONFIDENTIAL

Figure 122 shows the top view of the 3G wireless WAN HWIC.

Figure 122 Top View of HWIC-3G-GSM

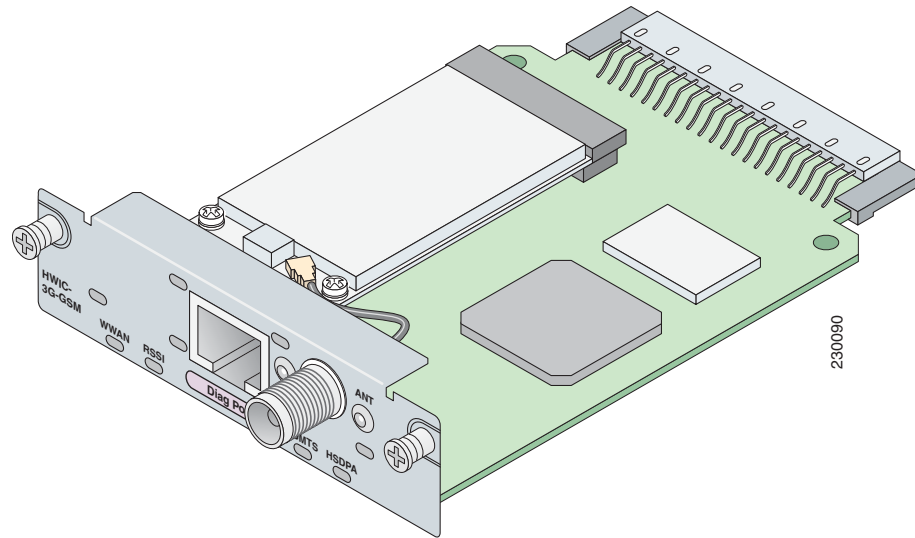
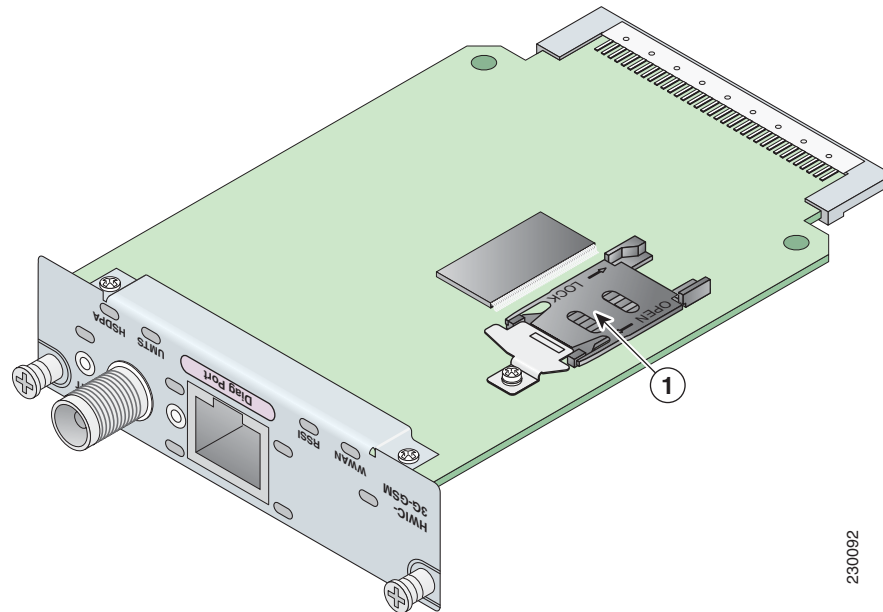

Figure 123 shows the bottom view of the 3G wireless WAN HWIC.

Figure 123 Bottom View of HWIC-3G-GSM



- 1 SIM Card Socket

REVIEW DRAFT – CISCO CONFIDENTIAL**HWIC-3G-CDMA**

The CDMA version supports multiple bands and services:

- 800/1900 MHz for 1xRTT
- 800/1900 MHz for EVDO—Release 0 and Release A

HWIC-3G-CDMA-*x* is the Cisco part number for which the interface card is configured. *x* is a variable for carrier-specific versions.

The CDMA 3G wireless HWICs support diversity mode (dual antenna mode) in the antennas. Types of antennas include swivel-mounted dipole with extended base and ceiling-mounted antennas. The diversity mode requires two antennas located together and spaced a minimum of 7.5 inches (19 cm) for better RF reception.

Figure 124 shows the front panel view of a CDMA 3G wireless WAN HWIC.

Figure 124 HWIC-3G-CDMA Front Panel

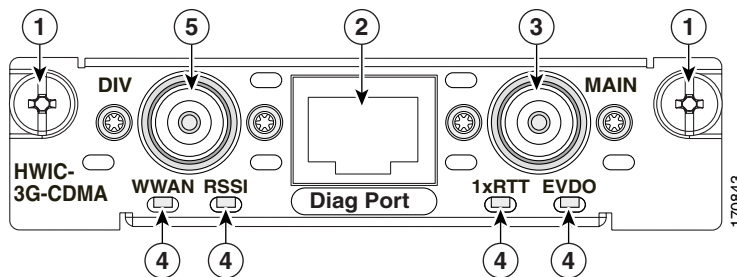

1	Mounting Screws	4	LEDs
2	Diagnostic Port	5	Diversity Antenna Connector
3	Main Antenna Connector		

REVIEW DRAFT – CISCO CONFIDENTIAL

Figure 125 shows the top view of a CDMA 3G wireless WAN HWIC.

Figure 125 **Top View of HWIC-3G-CDMA**

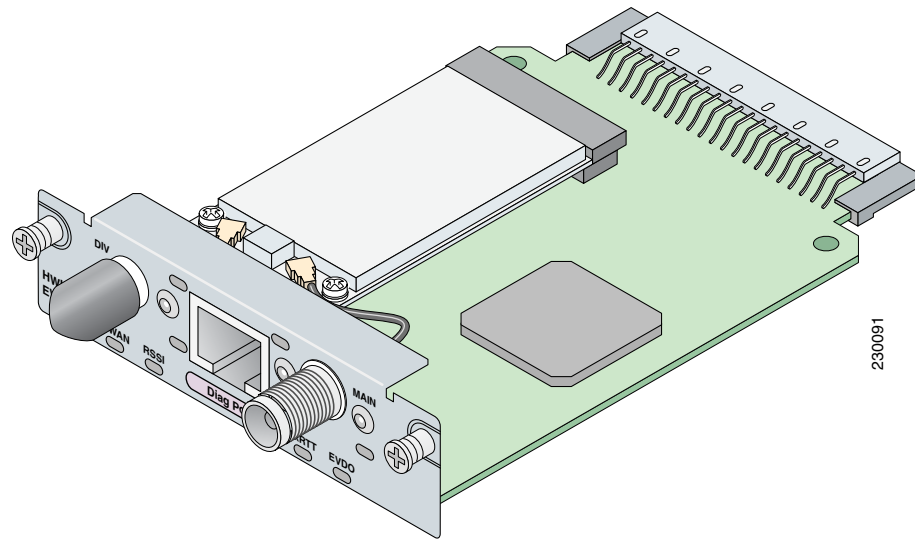
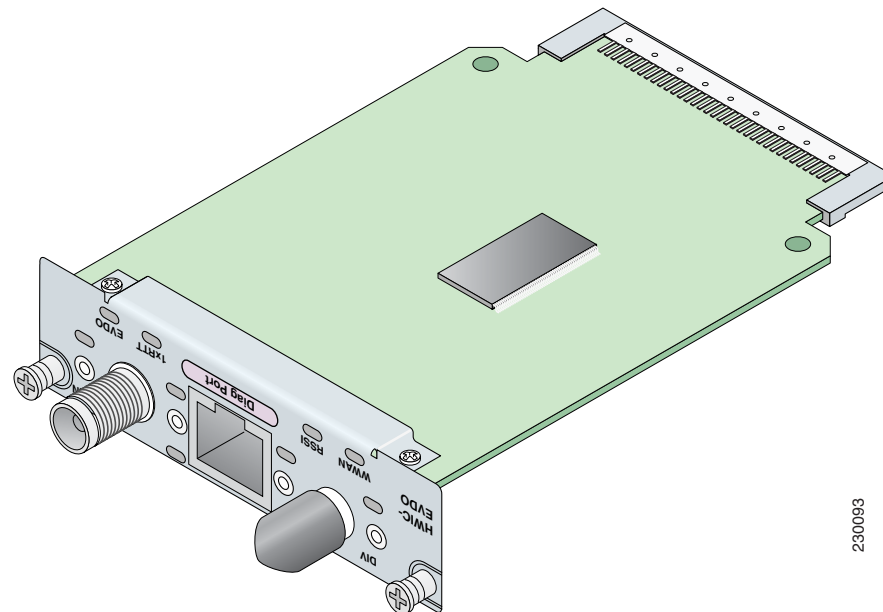

Figure 126 shows the bottom view of a CDMA 3G wireless WAN HWIC.

Figure 126 **Bottom View of HWIC-3G-CDMA**



REVIEW DRAFT – CISCO CONFIDENTIAL

Prerequisites

Before you connect, make sure you have done the following:

- If you are a Cisco HWIC-3G-GSM user, before you connect the HWIC to the network, you need to install the SIM card. See the “Installing a SIM Card in the HWIC-3G-GSM” section on page 7.
- Make sure you have subscribed to an appropriate GSM or CDMA service plan with your wireless service provider.
- Choose an antenna that best suits your needs. See the “Connecting an Antenna with the 3G Wireless WAN HWIC” section on page 10.

**Warning**

This equipment must be connected to an indoor antenna only. Statement 373

- Although the use of two antennas is not required, both antennas can be used to take advantage of diversity antenna mode for the best RF performance.
- Contact your carrier for information on network coverage, signal strength, choosing a suitable antenna, and antenna placement.

**Note**

The diagnostics port is to be used as an advanced diagnostics tool. Do not use this port for normal operations.

Restrictions

Limitations of the 3G wireless HWICs include the following:

- Only one 3G wireless HWIC is supported in the router at a time. Multiple 3G wireless HWICs on a single chassis is not a supported configuration at this time.
- The 3G wireless HWIC must be installed in an HWIC slot. To determine which slots on your platform support HWICs, see the “Platform Slot Numbering and Limitations for Cisco Interface Cards” section on page 8.

REVIEW DRAFT – CISCO CONFIDENTIAL**Installing a SIM Card in the HWIC-3G-GSM**

To install a SIM card onto the GSM HWIC, follow these steps:

- Step 1** On the bottom side of the 3G wireless HWIC, remove the bracket by unscrewing the M2.5 screw. See Figure 127 for details.

Figure 127 SIM Card installation Step 1

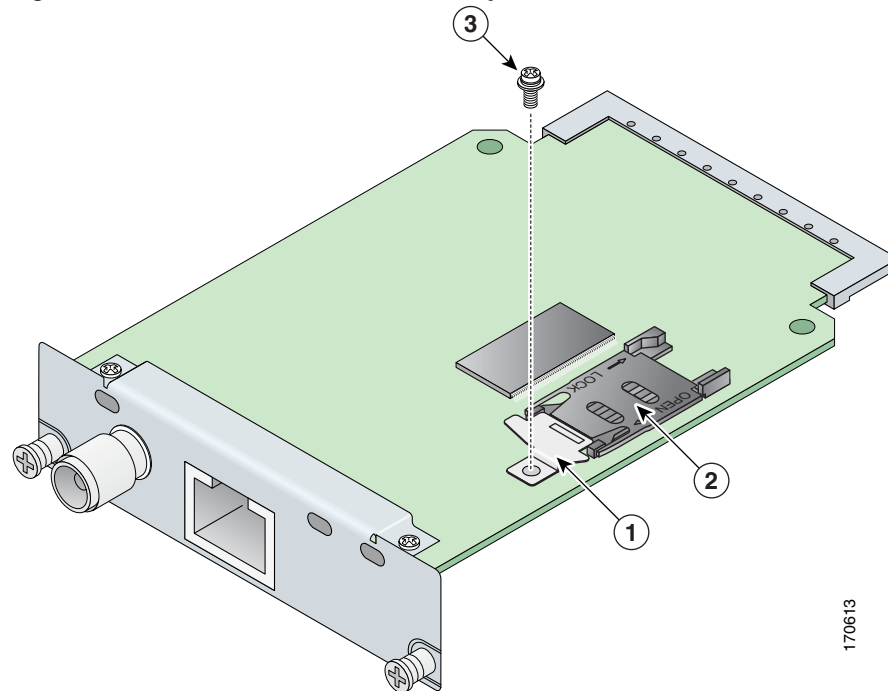

170613

1	SIM Card Bracket	3	M2.5 screw
2	SIM socket		

REVIEW DRAFT – CISCO CONFIDENTIAL

- Step 2** To open the SIM cover, slide it in the direction of the “Open” arrows. Then lift the hinged cover. See Figure 128 for details.

Figure 128 SIM Cards Installation Step 2

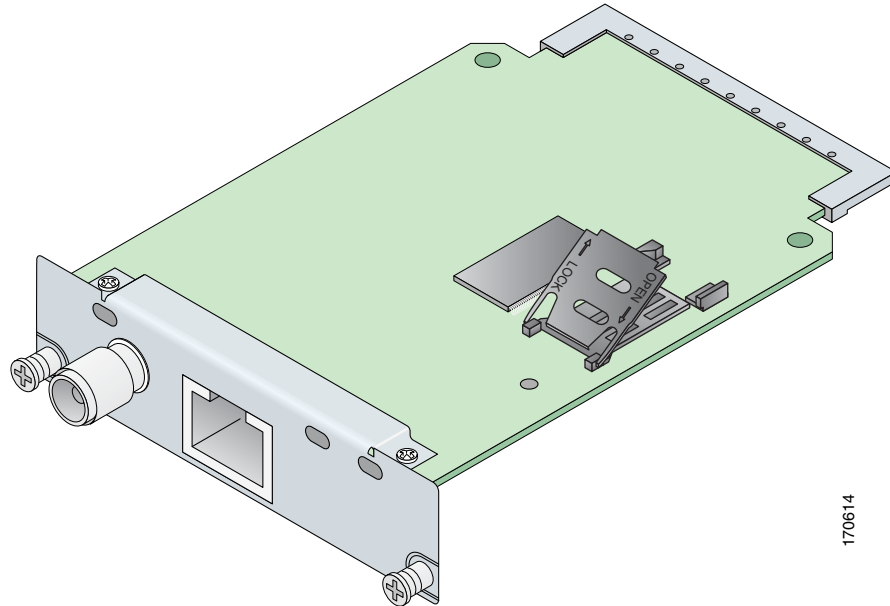

- Step 3** Slide the SIM card into the slot of the open cover. See Figure 129 for details.

**Note**

The SIM card is keyed. Make sure that the chamfer is oriented as shown in Figure 129, and the gold-plated contacts face downward to make contact with the contact pins of the SIM socket.

REVIEW DRAFT – CISCO CONFIDENTIAL

Figure 129 SIM Card Installation Step 3

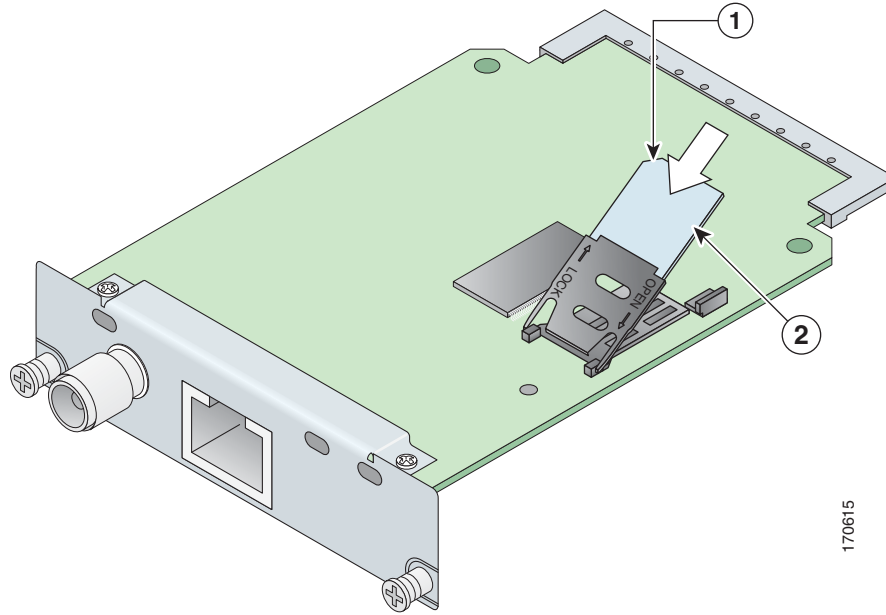

170615

1	Chamfer	2	SIM Card
----------	---------	----------	----------

Step 4 Close the cover by pushing it down and then sliding into the direction of the “Lock” arrows until it locks into place. Install the bracket back with the M2.5 screw as shown in Figure 130.

Figure 130 SIM Card Installation Step 4

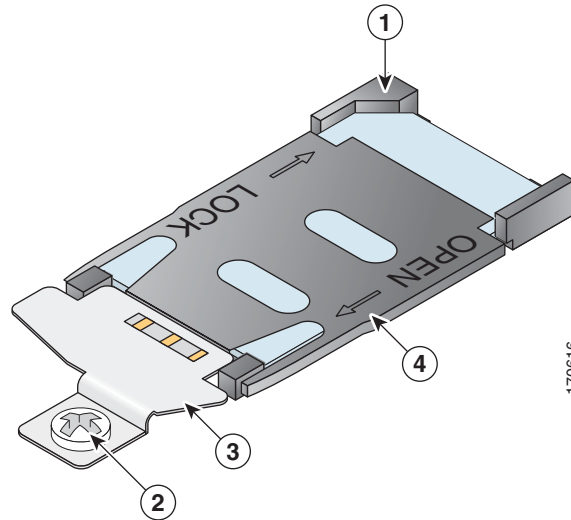

170616



1	Chamfer lined with keyed socket	3	Bracket
2	M2.5 Screw	4	SIM Card

REVIEW DRAFT – CISCO CONFIDENTIAL

3G Wireless HWIC LEDs

The 3G wireless HWIC LEDs are shown in Figure 121 and Figure 124. The functions of the LEDs are described in Table 36.

Table 36 **3G wireless HWIC LED Description**

LED	Description
Received Signal Strength Indication (RSSI) LED	Off: Low RSSI (under -100 dBm).
	Slow Green Blink: Low or medium RSSI (-99 to -90 dBm).
	Fast Green Blink: Medium RSSI (-89 to -70 dBm).
	Solid Green: High RSSI (-69 dBm or higher).
	Solid Yellow: No service or no RSSI detected.
WWAN LED (Per PCI Express Mini-card Wireless WAN Standard)	Off: HWIC in reset mode or not powered.
	Slow blink: Searching for service.
	Solid Green: Active service; no traffic detected.
	Fast Blink: Active service, and traffic detected is proportional to blink rate.
Service Type LEDs (CDMA HWIC)	1xRTT: 1xRTT is the active service.
	EVDO: 1xEVDO is the active service.
	Both Off: No service is active. Both On: Both services available.
	 Note If the RSSI LED is solid yellow, it indicates that no service and no RSSI is detected.
Service Type LEDs (GSM HWIC)	UMTS: UMTS is the active service.
	HSDPA: HSDPA is the active service.
	Both Off: Fallback service(GPRS or EDGE) is active.
	 Note If the RSSI LED is solid yellow, it indicates that no service and no RSSI is detected.

Connecting an Antenna with the 3G Wireless WAN HWIC

This section contains the following sub-sections:

- Wireless Access Devices Safety Guidelines and Warnings, page 11
- Prerequisites for Connecting Antennas, page 12
- Supported Cisco Antennas and Cables, page 13
- Connecting Swivel-Mount Dipole Antennas, page 14

REVIEW DRAFT – CISCO CONFIDENTIAL

- Faceplate-Mounted and Ceiling-Mounted Antennas and Cabling, page 15

Wireless Access Devices Safety Guidelines and Warnings

The following are guidelines for wireless access devices:

- Do not touch or move antenna(s) while the unit is transmitting or receiving.
- Do not hold any component containing a radio so that the antenna is very close to or touching any exposed parts of the body, especially the face or eyes, while transmitting.
- The use of wireless devices in hazardous locations is limited to the constraints posed by the local codes, the national codes, and the safety directors of such environments.

**Warning**

Before working on a chassis or working near power supplies, unplug the power cord on AC units; disconnect the power at the circuit breaker on DC units. Statement 12

**Warning**

When handling the HWICs and antennas, wear grounding wrist straps to avoid ESD damage to the card. Do not directly touch the backplane with your hand or any metal tool, or you could shock yourself. Statement 94

**Warning**

Do not operate your wireless network device near unshielded blasting caps or in an explosive environment unless the device has been modified to be especially qualified for such use. Statement 245B

**Warning**

In order to comply with FCC radio frequency (RF) exposure limits, antennas should be located at a minimum of 7.9 inches (20 cm) or more from the body of all persons. Statement 332

**Warning**

This equipment must be connected to an indoor antenna only. Statement 373

**Warning**

Do not work on the system or connect or disconnect cables during periods of lightning activity. Statement 1001

**Warning**

Read the installation instructions before connecting the system to the power source. Statement 1004

**Warning**

Ultimate disposal of this product should be handled according to all national laws and regulations. Statement 1040

REVIEW DRAFT – CISCO CONFIDENTIAL**Prerequisites for Connecting Antennas**

This section contains information about connecting the antennas.

**Note**

Before you connect the antennas, install the 3G wireless HWIC in the router. See Chapter , “Installing Cisco Interface Cards in Cisco Access Routers,” for more information.

In addition to antenna orientation, installation location with respect to other wireless equipment and other RF noise sources, such as telecom and datacom equipment, plays a significant role in determining overall network performance.

Because antennas transmit and receive radio signals, their performance can be adversely affected by the surrounding environment, including distance between HWIC antenna and cellular base station, physical obstructions, or radio frequency (RF) interference.

Follow these guidelines to ensure the best possible performance:

- Wherever possible, mount the 3G wireless HWIC antenna away from physical obstructions. Barriers along the line of sight between HWIC antenna and cellular base station will degrade the wireless radio signals. The 3G wireless HWICs and antennas can be installed above floor level in office environments or near the ceiling for better performance because most obstructions tend to be near floor level.
- The density of the materials used in a building’s construction determines the number of walls the signal must pass through and still maintain adequate coverage. Consider the following before choosing the location to install your antenna:
 - Paper and vinyl walls have very little effect on signal penetration.
 - Solid and precast concrete walls limit signal penetration to one or two walls without signal degradation.
 - Concrete and wood block walls limit signal penetration to three or four walls.
 - A signal can penetrate five or six walls constructed of drywall or wood.
 - A thick metal wall or a wire-mesh stucco wall causes signals to reflect back and causes poor penetration.
- Avoid mounting the antenna next to a column or vertical support that could create a shadow zone and reduce the coverage area.
- Keep the antenna away from reflective metal objects such as heating and air-conditioning ducts, large ceiling trusses, building superstructures, and major power cabling runs. If necessary, use an extension cable to relocate the antenna away from these obstructions.

**Caution**

Install the 3G wireless HWIC and any antennas away from appliances that share the same frequency bands. Microwave ovens, cordless telephones, and security monitors can temporarily interfere with wireless performance.

**Caution**

We recommend you avoid installing wireless antennas in or near rack-mounted installations that include networking equipment and computer servers whose radiated noise emissions can severely degrade radio performance.

REVIEW DRAFT – CISCO CONFIDENTIAL**Note**

If the desired installation site has a marginally acceptable level of radiated noise emissions, consider using a remotely-mounted antenna, such as a wall-mounted or ceiling-mounted antenna, for better radio performance and coverage.

Supported Cisco Antennas and Cables

Table 37 lists the Cisco antennas that are supported for use on the 3G wireless WAN HWIC

Table 37 Cisco Antennas Supported on the 3G Wireless HWIC

Cisco Part Number	Antenna Type	Maximum Gain and Frequency Range	Description
3G-ANTM1919D	Dipole Omnidirectional	0 dBi (806–960 MHz) 0 dBi (1710–2170 MHz)	This is the default antenna. Multiband faceplate mounted dipole antenna. This antenna is included with all faceplate-mounted 3G wireless WAN HWICs. For more information, see the <i>Cisco Multiband Swivel Mount Dipole Antenna (3G-ANTM1919D)</i> document.
3G-ANTM1916-CM	High-Gain Ceiling Mount Omnidirectional	1.5 dBi (806–960 MHz) 2.5 dBi (1710–2170 MHz)	Multiband ceiling-mounted omnidirectional antenna. For more information, see the <i>Cisco Multiband Omnidirectional Ceiling Mount Antenna (3G-ANTM1916-CM)</i> document.
3G-AE015-R (Antenna Extension)	Extension Base	0.8 GHz–6.0 GHz	This antenna extension is a base with a 15-foot cable included for use with dipole omnidirectional antennas. For more information, see the <i>Cisco Extended Antenna Base (3G-AE015-R)</i> document.

Table 38 lists insertion loss information for the ultra-low loss LMR 400 extension cables available from Cisco for use with the ceiling-mounted antenna. For more information about antenna cables, see the *Antenna Cabling* document.

Table 38 Cisco Extension Cables for Use with Antennas

Cisco Product Number	Cable Length	Insertion Loss	Frequency (MHz)
3G-CAB-ULL-20	20 ft (6 m)	1.50 dB max.	2100
3G-CAB-ULL-50	50 ft (15 m)	3.50 dB max.	2100

REVIEW DRAFT – CISCO CONFIDENTIAL

Figure 131 shows the various antenna options with the 3G wireless WAN HWIC.

Figure 131 **Antenna Options**

Connecting Swivel-Mount Dipole Antennas

If you are using Cisco swivel-mounted dipole antennas, follow these steps:

-
- Step 1** Attach an antenna to each TNC antenna connectors on the front of the 3G wireless HWIC and tighten it hand-tight.
- Step 2** Orient the antennas, depending on how you intend to mount the router in which the 3G wireless HWIC is installed.
- If the router is on a table or desk, orient the antennas to the left and right sides so that they are at a 90-degree angle to each other. (See Figure 131.)
 - If the router is on a vertical surface, such as a wall, orient the antennas up and at a 90-degree angle to each other.
 - If the router is on a ceiling, orient the antennas down and at a 90-degree angle to each other.
-

**Note**

Although it is not absolutely necessary, for best RF performance, do not attach the dipole antenna directly to the face-plate of the 3G wireless HWIC. Use the antenna extension cable and antenna base recommended for the product.

REVIEW DRAFT – CISCO CONFIDENTIAL

For more information about connecting the 3G-ANTM-1919D to the HWIC-3G-GSM or HWIC-3G-CDMA, see the *Cisco Multiband Swivel Mount Dipole Antenna (3G-ANTM1919D)* document.

For more information about connecting the 3G-ANTM1916-CM to the HWIC-3G-GSM or HWIC-3G-CDMA, see the *Cisco Multiband Omnidirectional Ceiling Mount Antenna (3G-ANTM1916-CM)* document.

Faceplate-Mounted and Ceiling-Mounted Antennas and Cabling

Depending on the wireless environment, wall-mounted or ceiling-mounted antennas may be preferred for optimum radio coverage. If the length of the coaxial antenna cable is insufficient to cover the distance between the 3G wireless HWIC and the location of the installed antenna, you can use ultra-low-loss TNC extension cables between the 3G wireless HWIC and the antenna cable.

RF energy is carried between the antennas and the radio equipment through a coaxial cable. An antenna cable introduces signal loss in the antenna system for both the transmitter and the receiver. Although the cable run can be 100 feet (30 m) or more from the 3G wireless HWIC to antenna locations, the longer the cable run, the greater the signal loss. To reduce signal loss, minimize the cable length and use only ultra-low-loss antenna cables to connect radio devices to antennas.

To connect faceplate-mounted or ceiling-mounted antennas, follow the installation instructions for your antenna:

- For more information about connecting the 3G-ANTM1919D to the HWIC, see the *Cisco Multiband Swivel Mount Dipole Antenna (3G-ANTM1919D)* document.
- For more information about connecting the 3G-ANT1916-CM to the HWIC, see the *Cisco Multiband Omnidirectional Ceiling Mount Antenna (3G-ANTM1916-CM)* document.
- For more information about connecting the 3G-AE015-R the HWIC, see the *Cisco Extended Antenna Base (3G-AE015-R)* document.

Related Documentation

Related documentation is available on Cisco.com or on the Product Documentation DVD. Refer to the following documents for additional information about the 3G wireless WAN interface cards.

- *Cisco Wireless ISR and HWIC Access Point Configuration Guide*
- *Cisco Multiband Swivel Mount Dipole Antenna (3G-ANTM1919D)*
- *Cisco Multiband Omnidirectional Ceiling Mount Antenna (3G-ANTM1916-CM)*
- *Cisco Extended Antenna Base (3G-AE015-R)*

REVIEW DRAFT – CISCO CONFIDENTIAL

Obtaining Documentation, Obtaining Support, and Security Guidelines

For information on obtaining documentation, obtaining support, providing documentation feedback, security guidelines, and also recommended aliases and general Cisco documents, see the monthly *What's New in Cisco Product Documentation*, which also lists all new and revised Cisco technical documentation, at:

<http://www.cisco.com/en/US/docs/general/whatsnew/whatsnew.html>

CCVP, the Cisco logo, and Welcome to the Human Network are trademarks of Cisco Systems, Inc.; Changing the Way We Work, Live, Play, and Learn is a service mark of Cisco Systems, Inc.; and Access Registrar, Aironet, Catalyst, CCDA, CCDP, CCIE, CCIP, CCNA, CCNP, CCSP, Cisco, the Cisco Certified Internetwork Expert logo, Cisco IOS, Cisco Press, Cisco Systems, Cisco Systems Capital, the Cisco Systems logo, Cisco Unity, Enterprise/Solver, EtherChannel, EtherFast, EtherSwitch, Fast Step, Follow Me Browsing, FormShare, GigaDrive, HomeLink, Internet Quotient, IOS, iPhone, IP/TV, iQ Expertise, the iQ logo, iQ Net Readiness Scorecard, iQuick Study, LightStream, Linksys, MeetingPlace, MGX, Networkers, Networking Academy, Network Registrar, PIX, ProConnect, ScriptShare, SMARTnet, StackWise, The Fastest Way to Increase Your Internet Quotient, and TransPath are registered trademarks of Cisco Systems, Inc. and/or its affiliates in the United States and certain other countries.

All other trademarks mentioned in this document or Website are the property of their respective owners. The use of the word partner does not imply a partnership relationship between Cisco and any other company. (0711R)

Any Internet Protocol (IP) addresses used in this document are not intended to be actual addresses. Any examples, command display output, and figures included in the document are shown for illustrative purposes only. Any use of actual IP addresses in illustrative content is unintentional and coincidental.

© 2007 Cisco Systems, Inc. All rights reserved.



Access Point High-Speed WAN Interface Cards

Revised: 6/7/07, OL-12854-01

Overview

This document describes access point high-speed WAN interface cards (HWICs) and how to connect access point HWICs to a network, and contains the following sections:

- Access Point High-Speed WAN Interface Cards, page 1
- Related Documentation, page 9
- Obtaining Documentation, Obtaining Support, and Security Guidelines, page 10

For an overview of Cisco interface cards used for Cisco access routers see the *Cisco Interface Cards for Cisco Access Routers* document.

Access Point High-Speed WAN Interface Cards

This section describes access point HWICs and contains the following sections:

- Access Point HWIC Limitations
- Access Point HWIC Safety Guidelines and Warnings
- Access Point HWIC LEDs
- Supported Cisco Radio Antennas
- Connecting Radio Antennas to the Access Point HWIC

The access point HWIC houses one radio (single-mode) or two radios (dual-mode) for connection to a wireless LAN. There are two access point HWICs:

- Single-mode access point HWIC with 2.4-GHz radio for 802.11b/g operations. (See Figure 132.)
The following are the Cisco part numbers and the geographic regions for which the interface cards are configured:
 - HWIC-AP-G-A—North America
 - HWIC-AP-G-E—Europe
 - HWIC-AP-G-J—Japan

Note

The wireless operations can be configured by using the Cisco Router and Security Device Manager (SDM) web-based application, or by using the Cisco IOS command-line interface (CLI). See the *Cisco Router and Security Device Manager (SDM) Quick Start Guide* or the *Cisco Access Router Wireless Configuration Guide* for more information.

- Dual-mode access point HWIC with two radios: one 2.4-GHz 802.11b/g radio and one 5-GHz 802.11a radio. (See Figure 133.) The following are the Cisco part numbers and the geographic regions for which the interface cards are configured:
 - HWIC-AP-AG-A—North America
 - HWIC-AP-AG-E—Europe

Note

Access point HWICs with the 5-GHz 802.11a radio that are used in Europe may be required to use Dynamic Frequency Selection (DFS) to detect and avoid interfering with radar signals to comply with that regulatory domain. DFS operates only on routers running Cisco IOS version 12.4(2)XA or higher.

- HWIC-AP-AG-J—Japan

Both the single-mode and dual-mode access point HWICs support diversity in the radio antennas. Types of antennas include swivel-mount dipole, wall-mount, and ceiling-mount antennas.

Note

For regulatory information about the access point HWIC and supported antennas, see the *Declarations of Conformity and Regulatory Information for Cisco Access Products with 802.11a/b/g and 802.11b/g Radios* document.

Figure 132 shows a single-mode access point HWIC, and Figure 133 shows a dual-mode access point HWIC.



Note

Although the single-mode access point HWIC has two sets of LEDs, the LEDs on the left side of the single-mode access point HWIC are nonfunctioning and do not light.

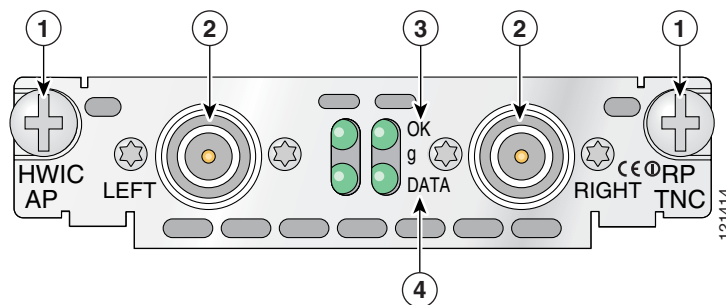
Figure 132 Single-Mode Access Point HWIC Front Panel

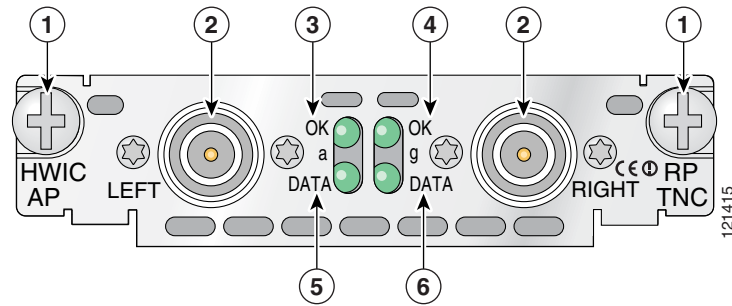

1	Mounting screws	3	OK LED for the 802.11b/g radio
2	RP-TNC connectors	4	DATA LED for the radio

Figure 133 Dual-Mode Access Point HWIC Front Panel

1	Mounting screws	4	OK LED for the 802.11b/g radio
2	RP-TNC connectors	5	DATA LED for the 802.11a radio
3	OK LED for the 802.11a radio	6	DATA LED for the 802.11b/g radio

Access Point HWIC Limitations

Limitations of the single-mode and dual-mode access point HWICs include the following:

- Only one access point HWIC is supported in the router at a time. Installation of two access point HWICs in the router is not supported.
- The access point HWIC must be installed in an HWIC slot. To determine which slots on your platform support HWICs, see the “Platform Slot Numbering and Limitations for Cisco Interface Cards” section on page 8.
- The 4.9-GHz band is not supported.
- Although the use of two antennas is not required, both antennas should be used to take advantage of diversity for the best RF performance.

Access Point HWIC Safety Guidelines and Warnings

The following are guidelines for wireless access devices:

- Do not touch or move antenna(s) while the unit is transmitting or receiving.
- Do not hold any component containing a radio so that the antenna is very close to or touching any exposed parts of the body, especially the face or eyes, while transmitting.
- The use of wireless devices in hazardous locations is limited to the constraints posed by the local codes, the national codes, and the safety directors of such environments.



Note

For regulatory information about the access point HWIC, see the *Declarations of Conformity and Regulatory Information for Cisco Access Products with 802.11a/b/g and 802.11b/g Radios* document.



Warning

Before working on a chassis or working near power supplies, unplug the power cord on AC units; disconnect the power at the circuit breaker on DC units. Statement 12

**Warning**

During this procedure, wear grounding wrist straps to avoid ESD damage to the card. Do not directly touch the backplane with your hand or any metal tool, or you could shock yourself. Statement 94

**Warning**

Do not operate your wireless network device near unshielded blasting caps or in an explosive environment unless the device has been modified to be especially qualified for such use. Statement 245B

**Warning**

In order to comply with FCC radio frequency (RF) exposure limits, antennas should be located at a minimum of 7.9 inches (20 cm) or more from the body of all persons. Statement 332

**Warning**

Do not work on the system or connect or disconnect cables during periods of lightning activity. Statement 1001

**Warning**

Read the installation instructions before connecting the system to the power source. Statement 1004

**Warning**

Ultimate disposal of this product should be handled according to all national laws and regulations. Statement 1040

Access Point HWIC LEDs

The access point HWIC LEDs are shown in Figure 132 and Figure 133. The functions of the LEDs are described in Table 39.

Table 39 **Access Point HWIC LEDs**

LED	Description
OK	Off if the access point HWIC is administratively shut down or there is no service set identifier (SSID) configured.
	Blinks if an SSID is configured but there is no client associated.
	On (solid green) if one or more clients are associated.
DATA	Off if the access point HWIC is administratively shut down or there is no SSID configured.
	Blinks if there is activity (sending or receiving packets).

Supported Cisco Radio Antennas

Table 40 lists the Cisco antennas that are supported for use on the single-mode access point HWIC.

Table 40 Cisco Antennas Supported on the Single-Mode Access Point HWIC

Cisco Part Number	Antenna Type	Maximum Gain	Description
AIR-ANT4941	Omnidirectional	2.2 dBi	This is the default antenna. Swivel-mount dipole antenna operating in the 2.4-to 2.5-GHz band. This antenna is designed for use with Cisco wireless products utilizing an RP-TNC connector. For more information, see the <i>Cisco Aironet 2.4 GHz Articulated Dipole Antenna (AIR-ANT4941)</i> document.
AIR-ANT1728	Omnidirectional	5.2 dBi	Ceiling-mount antenna operating in the 2.4- to 2.5-GHz band. This antenna has a clip that allows it to be mounted to a drop-ceiling cross member. For more information, see the <i>Cisco Aironet High-Gain Omnidirectional Ceiling Mount Antenna (AIR-ANT1728)</i> document. Note This antenna is not supported in Japan.
AIR-ANT3549	Patch	9 dBi	Wall-mount antenna operating in the 2.4- to 2.5-GHz band. Note This antenna is not supported in the United States and Canada.
AIR-ANT5959	Diversity omnidirectional	2 dBi	Ceiling-mount antenna operating in the 2.4- to 2.5-GHz band. This antenna has a clip that allows it to be mounted to a drop-ceiling cross member. For more information, see the <i>Cisco Aironet 2-dBi Diversity Omnidirectional Ceiling Mount Antenna (AIR-ANT5959)</i> document.

Table 41 lists the Cisco antennas that are supported for use on the dual-mode access point HWIC.

Table 41 Cisco Antennas Supported on the Dual-Mode Access Point HWIC

Cisco Part Number	Antenna Type	Maximum Gain	Description
AIR-ANTM2050D-R	Omnidirectional	<ul style="list-style-type: none"> 2.2 dBi in the 2.4-GHz band 5 dBi in the 5-GHz band 	This is the default antenna. Swivel-mount dipole antenna operating in the 2.4- to 2.5-GHz band. This antenna is designed for use with Cisco wireless products utilizing an RP-TNC connector. For more information, see the <i>Cisco Multiband Swivel-Mount Dipole Antenna (AIR-ANTM2050D-R)</i> document.
AIR-ANTM4050V-R	Diversity omnidirectional	<ul style="list-style-type: none"> 4 dBi in the 2.4-GHz band 5 dBi in the 5-GHz band 	Ceiling-mount antenna operating in the 2.4- to 2.5-GHz band. This antenna has a clip that allows it to be mounted to a drop-ceiling cross member. For more information, see the <i>Cisco Multiband Diversity Omnidirectional Ceiling-Mount Antenna (AIR-ANTM4050V-R)</i> document.
AIR-ANTM5560P-R	Patch	<ul style="list-style-type: none"> 5.5 dBi in the 2.4-GHz band 6 dBi in the 5-GHz band 	Wall-mount antenna operating in the 2.4- to 2.5-GHz band. For more information, see the <i>Cisco Multiband Wall-Mount Antenna (AIR-ANTM5560P-R)</i> document.

Connecting Radio Antennas to the Access Point HWIC

This section contains information about connecting the radio antennas.



Note

Before connecting the radio antennas, install the access point HWIC in the router. See *Installing Cisco Interface Cards in Cisco Access Routers* for more information.

In addition to antenna orientation, wireless access point installation location with respect to all wireless clients plays a significant role in determining overall network performance. Clients at the furthest coverage points might have 10% to 50% of the bandwidth of clients close to it. Wireless network coverage in one area or location might need to be lowered to improve the performance of other clients.

Because antennas transmit and receive radio signals, their performance can be adversely affected by the surrounding environment including distance between access point and client, physical obstructions, or radio frequency (RF) interference.

Follow these guidelines to ensure the best possible performance:

- Wherever possible, mount the access point HWIC and antenna where the wireless devices would be within sight and avoid physical obstructions. Barriers along the line of sight between client and access point will degrade the wireless radio signals. access point HWICs and antennas can be installed above floor level in office environments or near the ceiling for better performance since most obstructions tend to be near floor level.

- The density of the materials used in a building's construction determines the number of walls the signal must pass through and still maintain adequate coverage. Consider the following before choosing the location to install your antenna:
 - Paper and vinyl walls have very little effect on signal penetration.
 - Solid and precast concrete walls limit signal penetration to one or two walls without degrading coverage.
 - Concrete and wood block walls limit signal penetration to three or four walls.
 - A signal can penetrate five or six walls constructed of drywall or wood.
 - A thick metal wall or wire-mesh stucco walls causes signals to reflect back and cause poor penetration.
- Avoid mounting the antenna next to a column or vertical support that could create a shadow zone and reduce the coverage area.
- Keep the antenna away from reflective metal objects such as heating and air-conditioning ducts, large ceiling trusses, building superstructures, and major power cabling runs. If necessary, use an extension cable to relocate the antenna away from these obstructions.

**Caution**

Install the access point HWIC and any antennas away from appliances that share the same frequency bands. Microwave ovens, cordless telephones, and security monitors can temporarily interfere with wireless performance.

**Caution**

We recommend you avoid installing wireless antennas in or near rack-mounted installations that include networking equipment and computer servers whose radiated noise emissions can severely degrade radio performance.

**Note**

If the desired installation site has a marginally acceptable level of radiated noise emissions, consider using a remote-mounted antenna, such as a wall-mount or ceiling-mount antenna, for better radio performance and coverage.

Swivel-Mount Dipole Antennas

If you are using Cisco swivel-mount dipole antennas, follow these steps:

- Step 1** Attach an antenna to each of the RP-TNC antenna connectors on the front of the access point HWIC and tighten it hand-tight.
- Step 2** Orient the antennas depending on how you intend to mount the router in which the access point HWIC is installed.
 - If the router is on a table or desk, orient the antennas to the left and right sides so that they are at a 90-degree angle to each other. (See Figure 134.)
 - If the router is on a vertical surface, such as a wall, orient the antennas up and at a 90-degree angle to each other.
 - If the router is on a ceiling, orient the antennas down and at a 90-degree angle to each other.

**Note**

Although it is not absolutely necessary, for best RF performance, orient the antennas as shown in Figure 134.

Figure 134 Swivel-Mount Dipole Antenna Positions for Use with Desktop Router

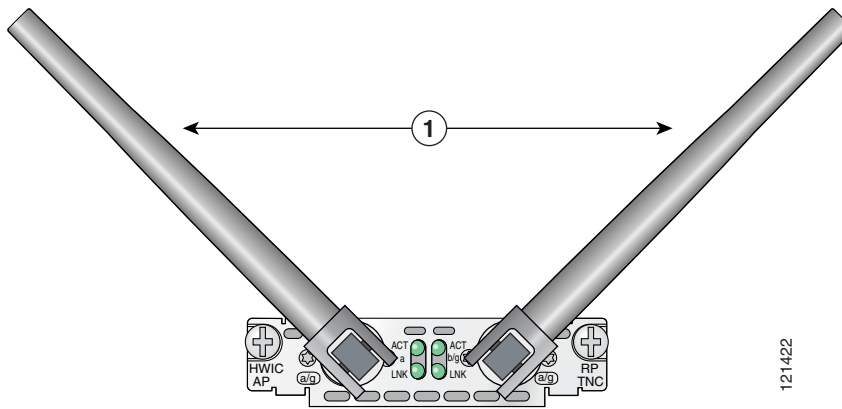

1	Swivel-mount dipole antennas		
----------	------------------------------	--	--

For more information about connecting the AIR-ANT4941 to the HWIC-AP-G, see the *Cisco Aironet 2.4-GHz Articulated Dipole Antenna (AIR-ANT4941)* document.

For more information about connecting the AIR-ANTM2050D-R to the HWIC-AP-AG, see the *Cisco Multiband Swivel-Mount Dipole Antenna (AIR-ANTM2050D-R)* document.

Wall-Mount and Ceiling-Mount Antennas and Cabling

Depending on the wireless environment, wall-mounted or ceiling-mounted antennas may be preferred for optimum radio coverage. If the length of the coaxial antenna cable is insufficient to cover the distance between the access point HWIC and the location of the installed antenna, you can use low-loss RP-TNC extension cables between the access point HWIC and the antenna cable.

RF energy is carried between the antennas and the radio equipment through a coaxial cable. An antenna cable introduces signal loss in the antenna system for both the transmitter and the receiver. Although the cable run can be 100 feet (30 m) or more from the access point HWIC to antenna locations, the longer the cable run, the greater the signal loss. To reduce signal loss, minimize the cable length and use only low-loss or ultra low-loss antenna cables to connect radio devices to antennas.

Table 42 lists transmission loss information about low-loss and ultra-low-loss extension coaxial cables available from Cisco. For more information about antenna cables, see the *Antenna Cabling* document.

Table 42 **Cisco Extension Coaxial Cables**

Cisco Product Number	Cable Length	Transmission Loss
AIR-CAB020LL-R	20 ft (6 m)	<ul style="list-style-type: none"> • 2.4-GHz: 1.3 dBi • 5-GHz: 2.5 dBi
AIR-CAB050LL-R	50 ft (15 m)	<ul style="list-style-type: none"> • 2.4-GHz: 3.3 dBi • 5-GHz: 5.75 dBi
AIR-CAB100ULL-R	100 ft (30 m)	<ul style="list-style-type: none"> • 2.4-GHz: 4.4 dBi • 5-GHz: 7.25 dBi
AIR-CAB150ULL-R	150 ft (46 m)	<ul style="list-style-type: none"> • 2.4-GHz: 6.6 dBi • 5-GHz: 11 dBi

To connect wall-mount or ceiling-mount antennas, follow the installation instructions for your antenna:

- For more information about connecting the AIR-ANT1728 to the HWIC-AP-G, see the *Cisco Aironet High-Gain Omnidirectional Ceiling Mount Antenna (AIR-ANT1728)* document.
- For more information about connecting the AIR-ANT5959 to the HWIC-AP-G, see the *Cisco Aironet 2-dBi Diversity Omnidirectional Ceiling Mount Antenna (AIR-ANT5959)* document.
- For more information about connecting the AIR-ANT4050V-R to the HWIC-AP-AG, see the *Cisco Multiband Diversity Omnidirectional Ceiling-Mount Antenna (AIR-ANTM4050V-R)* document.
- For more information about connecting the AIR-ANT5560P-R to the HWIC-AP-AG, see the *Cisco Multiband Wall-Mount Antenna (AIR-ANTM5560P-R)* document.

Related Documentation

Related documentation is available on Cisco.com or on the Product Documentation DVD. For more information, see the “Obtaining Documentation, Obtaining Support, and Security Guidelines” section on page 10.

- *Cisco Access Router Wireless Configuration Guide*
- *Declarations of Conformity and Regulatory Information for Cisco Access Products with 802.11a/b/g and 802.11b/g Radios*
- *Cisco Aironet 2.4 Ghz Articulated Dipole Antenna (AIR-ANT4941)*
- *Cisco Aironet High Gain Omnidirectional Ceiling Mount Antenna (AIR-ANT1728)*
- *Cisco Aironet 2 dBi Diversity Omnidirectional Ceiling Mount Antenna (AIR-ANT5959)*
- *Cisco Multiband Swivel-Mount Dipole Antenna (AIR-ANTM2050D-R)*
- *Cisco Multiband Diversity Omnidirectional Ceiling-Mount Antenna (AIR-ANTM4050V-R)*
- *Cisco Multiband Wall-Mount Antenna (AIR-ANTM5560P-R)*
- *Antenna Cabling*

Obtaining Documentation, Obtaining Support, and Security Guidelines

For information on obtaining documentation, obtaining support, providing documentation feedback, security guidelines, and also recommended aliases and general Cisco documents, see the monthly *What's New in Cisco Product Documentation*, which also lists all new and revised Cisco technical documentation, at:

<http://www.cisco.com/en/US/docs/general/whatsnew/whatsnew.html>

CCVP, the Cisco logo, and Welcome to the Human Network are trademarks of Cisco Systems, Inc.; Changing the Way We Work, Live, Play, and Learn is a service mark of Cisco Systems, Inc.; and Access Registrar, Aironet, Catalyst, CCDA, CCDP, CCIE, CCIP, CCNA, CCNP, CCSP, Cisco, the Cisco Certified Internetwork Expert logo, Cisco IOS, Cisco Press, Cisco Systems, Cisco Systems Capital, the Cisco Systems logo, Cisco Unity, Enterprise/Solver, EtherChannel, EtherFast, EtherSwitch, Fast Step, Follow Me Browsing, FormShare, GigaDrive, HomeLink, Internet Quotient, IOS, iPhone, IP/TV, iQ Expertise, the iQ logo, iQ Net Readiness Scorecard, iQuick Study, LightStream, Linksys, MeetingPlace, MGX, Networkers, Networking Academy, Network Registrar, PIX, ProConnect, ScriptShare, SMARTnet, StackWise, The Fastest Way to Increase Your Internet Quotient, and TransPath are registered trademarks of Cisco Systems, Inc. and/or its affiliates in the United States and certain other countries.

All other trademarks mentioned in this document or Website are the property of their respective owners. The use of the word partner does not imply a partnership relationship between Cisco and any other company. (0711R)

Any Internet Protocol (IP) addresses used in this document are not intended to be actual addresses. Any examples, command display output, and figures included in the document are shown for illustrative purposes only. Any use of actual IP addresses in illustrative content is unintentional and coincidental.

© 2007 Cisco Systems, Inc. All rights reserved.



Cisco Cable Modem High-Speed WAN Interface Cards

Revised: 6/7/07, OL-12855-01

Overview

This document describes Cisco cable modem high-speed WAN interface cards (HWICs) and how to connect Cisco cable modem HWICs to the network and contains the following sections:

- Cisco Cable Modem HWICs, page 1
- Accessibility, page 4
- Platform Support for Cisco Cable Modem HWICs, page 5
- Connecting the Cisco Cable Modem HWIC, page 6
- Obtaining Documentation, Obtaining Support, and Security Guidelines, page 7

For an overview of Cisco interface cards used for Cisco access routers see the *Cisco Interface Cards for Cisco Access Routers* document.

Cisco Cable Modem HWICs

This section describes the features of the Cisco cable modem HWICs and contains the following sections:

- Cisco Cable Modem HWIC (HWIC-CABLE-D-2), page 2
- Cisco Cable Modem HWIC (HWIC-CABLE-E/J-2), page 3
- Port Numbering, page 3
- LEDs, page 4

The Cisco cable modem HWICs allow the router to communicate over a cable high-speed data (HSD) network for office-to-Internet connectivity or for branch-to-branch connectivity. Supported on a wide range of platforms, the Cisco cable modem HWIC is suitable for deployments ranging from small office/home office (SOHO) to small and medium business (SMB) to enterprise branch offices. When the Cisco cable modem HWIC is combined with the powerful Cisco IOS software and Cisco access routers,

an unparalleled range of services becomes possible, all within a single, easily manageable platform. This combination allows a provider or business to minimize operational expenses while maximizing the potential return on invested capital.

The Cisco cable modem HWICs are designed to be fully compliant with DOCSIS 2.0 standards in the United States, Europe, and Japan. Cisco cable modem HWICs provide secure, high-speed connections over cable modem hybrid fiber-coaxial (HFC) cable network.

**Note**

To see the DOCSIS 2.0 U.S. requirements and specifications, see the ComLabs website at <http://www.cablemodem.com/specifications/specifications20.html>

To see Euro DOCSIS 2.0 requirements, see the tComLabs website at <http://www.excentis.com>

The following modules are available:

- 1-port DOCSIS 2.0 Cable Modem HWIC (HWIC-CABLE-D-2)
- 1-port Euro/J-DOCSIS 2.0 Cable Modem HWIC (HWIC-CABLE-E/J-2)

**Note**

Online insertion and removal (OIR) is not supported on the Cisco cable modem HWICs.

**Note**

Up to four Cisco cable modem HWICs can be inserted in the chassis, depending on the availability of chassis slots.

Cisco Cable Modem HWIC (HWIC-CABLE-D-2)

Figure 135 shows the faceplate of the Cisco cable modem HWIC, United States version (HWIC-CABLE-D-2).

Figure 135 Cisco Cable Modem HWIC (HWIC-CABLE-D-2) Faceplate

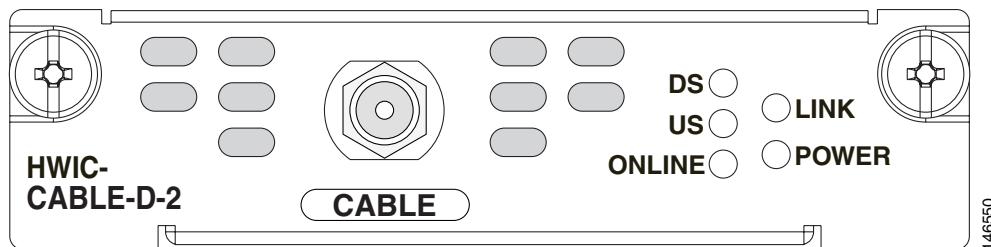

Cisco Cable Modem HWIC (HWIC-CABLE-E/J-2)

Figure 136 shows the faceplate of the Cisco cable modem HWIC, European and Japanese version (HWIC-CABLE-E/J-2).

Figure 136 Cisco Cable Modem HWIC (HWIC-CABLE-E/J-2) Faceplate

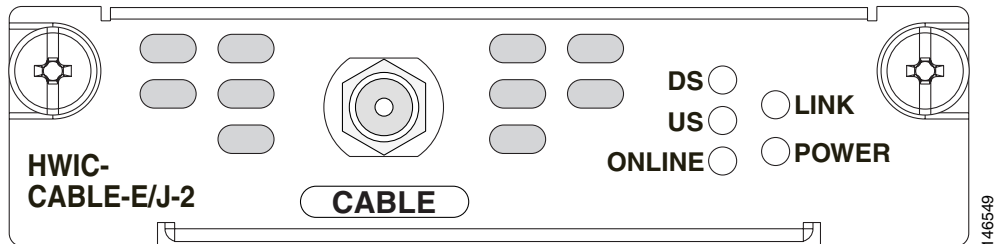

Port Numbering

Table 43 shows the different interface port types on the Cisco routers. For information about port numbering on interface cards in specific routers, see the *Cisco Interface Cards Installation Guide*.



Note

For specific information regarding port numbering for the routers that support Cisco cable modem HWICs, see the hardware installation documentation for your router at <http://www.cisco.com/>.

Table 43 Port Numbering on the Cisco Routers

Cisco Router	Interface Numbering
1841, 2800, and 3800 ISRs	x/y/z
IAD2431, 3725, 3745	x/y
815 ISR	x



Note

The slot number for all WIC interfaces on Cisco ISRs is always 0. (The W0 and W1 slot designations are for physical slot identification only.) Interfaces in the WICs are numbered from right to left, starting with 0/0 for each interface type, regardless of which physical slot the WICs are installed in.



Note

The slot for WICs on the Cisco 2430 IADs is numbered slot 0. WIC interfaces are numbered by interface with this slot number and an interface number, starting with 0 and continuing from right to left.

LEDs

The Cisco cable modem HWIC LEDs show green, orange, and off states for system and port status. Table 44 describes the Cisco cable modem HWIC LEDs and their meanings when the Cisco cable modem HWIC is going through the registration process.

Table 44 Cisco Cable Modem HWIC LED Meanings

LED	Meaning
DS	The DS (downstream) LED lights up and flashes when the cable modem scans for a DOCSIS channel and tries to lock on to a downstream signal. The LED stays solid when it has locked on to the DS DOCSIS channel. Note The DS LED blinks before the US (upstream) LED blinks.
US	The US (upstream) LED lights up and flashes when the cable modem scans for a DOCSIS channel and tries to lock on an upstream signal. The LED stays solid when it has locked on to the US DOCSIS channel.
ONLINE	The Online LED flashes when the cable modem is establishing a connection to the router. It stays solid when the cable modem is synchronized with the router.
LINK	The LED shows that a link is active when a CPE device is connected and the cable modem is not bridging data. The LINK LED pulses when the cable modem is bridging data in the cable modem operational state. Note The LINK LED does not pulse for data traffic that originates or terminates at the cable modem.
POWER	The Power LED lights up when the cable modem is powered on. It stays solid after the power-on self-test (POST). If the LED lights up red, the self-test has failed.

For more information about DOCSIS 2.0 compliant LED functionality, see the CableLabs website at <http://www.cablelabs.com>

Accessibility

These HWICs can be configured using the Cisco command-line interface (CLI). The CLI conforms to Section 508 of the Rehabilitation Act because it is text based and because it relies on a keyboard for navigation. All functions of the router can be configured and monitored through the CLI.

For a complete list of guidelines and Cisco products adherence to accessibility, see Cisco Accessibility Products at the following URL:

<http://www.cisco.com/web/about/responsibility/accessibility/products>

Platform Support for Cisco Cable Modem HWICs

The Cisco Data-Over-Cable Service Interface Specification (DOCSIS) cable modem HWICs are supported in the following Cisco routers: Cisco IAD2431 Integrated Access Devices; Cisco 3725, and Cisco 3745 routers; and Cisco 1800 (modular), Cisco 2800, and Cisco 3800 Integrated Services Routers (ISRs).



Note

The Cisco 815 ISR for Broadband Cable does not support WIC or HWIC modules, however, the underlying cable modem technology is identical to that of the cable modem HWIC.

Table 45 shows the Cisco router platforms that support the Cisco cable modem HWICs.

Table 45 Cisco Router Support for WICs and HWICs

Cisco Router	WIC	HWIC
815 ¹	Yes	No
Note The performance of the 815 matches the performance of the WIC mode. The cable modem in the 815 is a fixed configuration and is not field replaceable.		
1800	No	Yes
IAD2431 ¹	Yes	No
2800 series	No	Yes
3700 series ¹	Yes	No
3800 series	No	Yes

1. When the cable modem HWIC is placed in these routers, the HWIC operates only in WAN interface card (WIC) mode, providing total throughput on the cable modem HWIC of 16 MB (8 MB upstream and 8 MB downstream).



Note

For specific information about WIC/HWIC support for the routers that support the Cisco cable modem HWICs, see the hardware installation documentation for your router at www.cisco.com.

Finding Support Information for Platforms and Cisco IOS Software Images

Use Cisco Feature Navigator to find information about platform support and Cisco IOS software image support. Access Cisco Feature Navigator at <http://www.cisco.com/go/fn>. You must have an account on Cisco.com. If you do not have an account or have forgotten your username or password, click **Cancel** at the login dialog box and follow the instructions that appear.

Connecting the Cisco Cable Modem HWIC

To connect the Cisco cable modem HWIC to the router, follow these steps:

- Step 1** Verify that the router is powered off.
- Step 2** Insert the Cisco cable modem HWIC in the HWIC slot of the Cisco router.



Note For specific information regarding WIC/HWIC support for the routers that support Cisco cable modem HWICs, see the hardware installation documentation for your router at www.cisco.com.

- Step 3** Locate the RF coaxial cable coming from the coaxial cable CATV wall outlet.
- Step 4** Install a cable splitter/directional coupler, if needed, to separate signals for TV and computer usage. If necessary, also install a high-pass filter to prevent interference between the TV and computer signals.
- Step 5** Connect the RF coaxial cable to the Cisco cable modem HWIC F-connector. Hand-tighten the connector, making sure that it is finger tight; then give it a 1/6-turn with a wrench. See Figure 137

Figure 137 Connecting the CATV Coaxial Cable to the Cisco Cable Modem HWIC

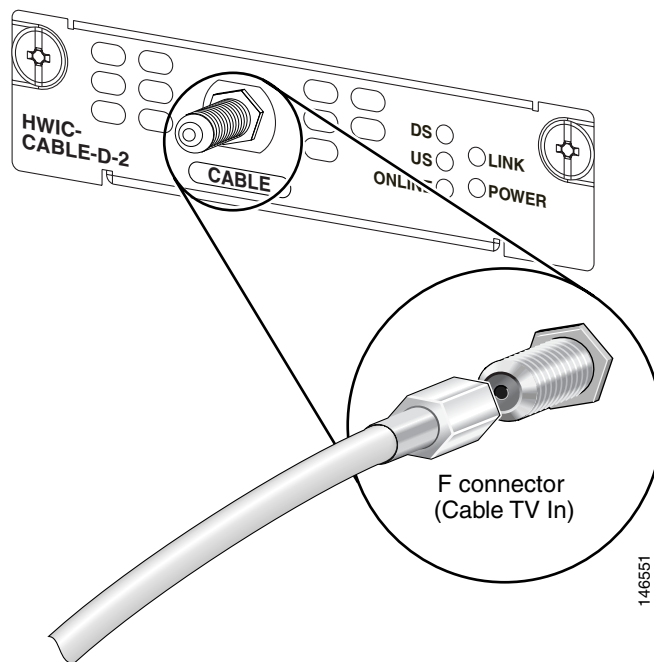

To cable source

- Step 6** Power on the router.

Obtaining Documentation, Obtaining Support, and Security Guidelines

For information on obtaining documentation, obtaining support, providing documentation feedback, security guidelines, and also recommended aliases and general Cisco documents, see the monthly *What's New in Cisco Product Documentation*, which also lists all new and revised Cisco technical documentation, at:

<http://www.cisco.com/en/US/docs/general/whatsnew/whatsnew.html>

CCVP, the Cisco logo, and Welcome to the Human Network are trademarks of Cisco Systems, Inc.; Changing the Way We Work, Live, Play, and Learn is a service mark of Cisco Systems, Inc.; and Access Registrar, Aironet, Catalyst, CCDA, CCDP, CCIE, CCIP, CCNA, CCNP, CCSP, Cisco, the Cisco Certified Internetwork Expert logo, Cisco IOS, Cisco Press, Cisco Systems, Cisco Systems Capital, the Cisco Systems logo, Cisco Unity, Enterprise/Solver, EtherChannel, EtherFast, EtherSwitch, Fast Step, Follow Me Browsing, FormShare, GigaDrive, HomeLink, Internet Quotient, IOS, iPhone, IP/TV, iQ Expertise, the iQ logo, iQ Net Readiness Scorecard, iQuick Study, LightStream, Linksys, MeetingPlace, MGX, Networkers, Networking Academy, Network Registrar, PIX, ProConnect, ScriptShare, SMARTnet, StackWise, The Fastest Way to Increase Your Internet Quotient, and TransPath are registered trademarks of Cisco Systems, Inc. and/or its affiliates in the United States and certain other countries.

All other trademarks mentioned in this document or Website are the property of their respective owners. The use of the word partner does not imply a partnership relationship between Cisco and any other company. (0711R)

Any Internet Protocol (IP) addresses used in this document are not intended to be actual addresses. Any examples, command display output, and figures included in the document are shown for illustrative purposes only. Any use of actual IP addresses in illustrative content is unintentional and coincidental.

© 2007 Cisco Systems, Inc. All rights reserved.



T1/E1 High-Speed WAN Interface Cards

Revised: 11/26/07

Overview

This chapter describes how to connect Cisco T1/E1 high-speed WAN interface cards (HWICs) to a network. It contains the following sections:

- Cisco T1/E1 HWICs, page 9
- Safety Warnings for Cisco T1/E1 HWICs, page 10
- Cisco T1/E1 HWIC LEDs, page 10
- Connecting a T1/E1 HWIC to a Network, page 12

Cisco T1/E1 HWICs

T1/E1 HWICs provide T1 and E1 support to Cisco 2800 series and Cisco 3800 series integrated services routers. T1 support has integrated CSU/DSU capability.

The following T1/E1 HWICs are available:

- 1-port channelized
- 2-port channelized
- 4-port clear channel

Supported platforms are:

- Cisco 2811
- Cisco 2821
- Cisco 2851
- Cisco 3825
- Cisco 3845

Safety Warnings for Cisco T1/E1 HWICs

The following safety warnings apply to installation procedures involving Cisco T1/E1 HWICs. Translations of these warnings are available in the *Cisco Network Modules and Interface Cards Regulatory Compliance and Safety Information* document, which is available online.



Warning

To avoid electric shock, do not connect safety extra-low voltage (SELV) circuits to telephone-network voltage (TNV) circuits. LAN ports contain SELV circuits, and WAN ports contain TNV circuits. Some LAN and WAN ports both use RJ-45 connectors. Use caution when connecting cables. Statement 1021



Warning

Hazardous network voltages are present in WAN ports regardless of whether power to the unit is OFF or ON. To avoid electric shock, use caution when working near WAN ports. When detaching cables, detach the end away from the unit first. Statement 1026

Cisco T1/E1 HWIC LEDs

T1/E1 HWICs have 2 LEDs for each port that indicate the functionality of the T1 or E1 connection. Figure 0-138, Figure 0-139, and Figure 0-140 show the front panels and LEDs on the 1-port, 2-port, and 4-port HWICs, respectively. The LEDs are described in Table 0-46.

Figure 0-138 1-Port T1/E1 HWIC Front Panel

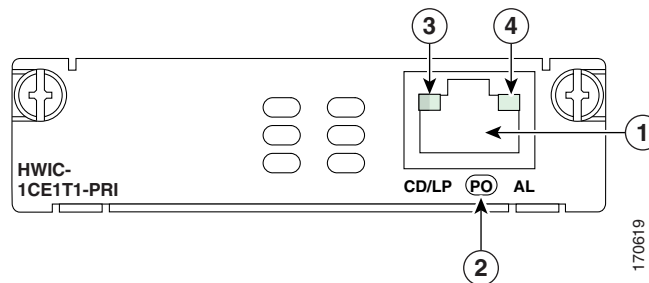

1	RJ-48C connector	2	Port number
3	CD/LP LED (bicolor LED)	4	AL LED

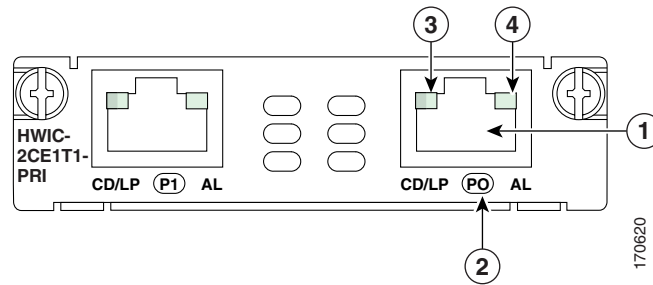
Figure 0-139 2-Port T1/E1 HWIC Front Panel

1	RJ-48C connector	2	Port number
3	CD/LP LED (bicolor LED)	4	AL LED

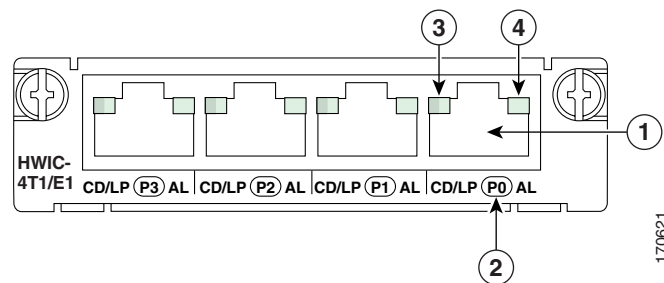
Figure 0-140 4-Port T1/E1 HWIC Front Panel

1	RJ-48C connector	2	Port number
3	CD/LP LED (bicolor LED)	4	AL LED

CD/LP LEDs are bicolor LEDs with both green and yellow emitters.

Table 0-46 T1/E1 HWIC LEDs

LED	Color	Description
CD/LP	Green/Yellow	Off: No carrier detected Green on (CD): Carrier detected Yellow on (LP): Port in loopback mode
AL	Yellow	Off: No alarms On: Port in alarm mode

Connecting a T1/E1 HWIC to a Network

Use straight-through RJ-48C-to-RJ-48C cables to connect T1/E1 ports to RJ-48C jacks. See the *Cisco Modular Access Router Cable Specifications* for pinouts.

To connect a T1/E1 port to the network, complete the following steps:

-
- Step 1** Connect one end of the cable to a T1/E1 port on the card.
 - Step 2** Connect the other end to the RJ-48C jack at your site, as shown in Figure 0-141.

Figure 0-141 Connecting a T1/E1 HWIC to an RJ-48C Jack

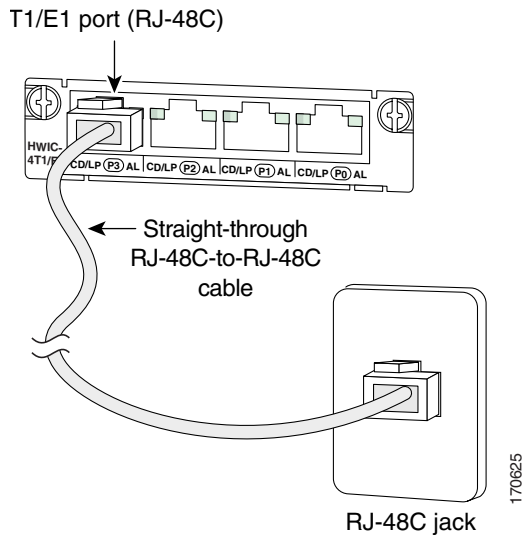

Additional References

For additional information, see the following documents and resources.

Related Topic	Document Title
Regulatory compliance and safety information	<i>Cisco Network Modules and Interface Cards Regulatory Compliance and Safety Information</i>
Cisco IOS software website and reference documentation	<i>Cisco IOS Software</i> http://www.cisco.com/en/US/products/sw/iosswrel/tsd_products_support_category_home.html
Technical documentation, including feedback and assistance	<i>What's New in Cisco Product Documentation</i> (including monthly listings of new and revised documents) at http://www.cisco.com/univercd/cc/td/doc/abtunicd/136957.htm

Obtaining Documentation, Obtaining Support, and Security Guidelines

For information on obtaining documentation, obtaining support, providing documentation feedback, security guidelines, and also recommended aliases and general Cisco documents, see the monthly *What's New in Cisco Product Documentation*, which also lists all new and revised Cisco technical documentation, at:

<http://www.cisco.com/en/US/docs/general/whatsnew/whatsnew.html>

CCVP, the Cisco logo, and Welcome to the Human Network are trademarks of Cisco Systems, Inc.; Changing the Way We Work, Live, Play, and Learn is a service mark of Cisco Systems, Inc.; and Access Registrar, Aironet, Catalyst, CCDA, CCDP, CCIE, CCIP, CCNA, CCNP, CCSP, Cisco, the Cisco Certified Internetwork Expert logo, Cisco IOS, Cisco Press, Cisco Systems, Cisco Systems Capital, the Cisco Systems logo, Cisco Unity, Enterprise/Solver, EtherChannel, EtherFast, EtherSwitch, Fast Step, Follow Me Browsing, FormShare, GigaDrive, HomeLink, Internet Quotient, IOS, iPhone, IP/TV, iQ Expertise, the iQ logo, iQ Net Readiness Scorecard, iQuick Study, LightStream, Linksys, MeetingPlace, MGX, Networkers, Networking Academy, Network Registrar, PIX, ProConnect, ScriptShare, SMARTnet, StackWise, The Fastest Way to Increase Your Internet Quotient, and TransPath are registered trademarks of Cisco Systems, Inc. and/or its affiliates in the United States and certain other countries.

All other trademarks mentioned in this document or Website are the property of their respective owners. The use of the word partner does not imply a partnership relationship between Cisco and any other company. (0711R)

Any Internet Protocol (IP) addresses used in this document are not intended to be actual addresses. Any examples, command display output, and figures included in the document are shown for illustrative purposes only. Any use of actual IP addresses in illustrative content is unintentional and coincidental.

© 2007 Cisco Systems, Inc. All rights reserved.

