



Cisco AccessPath-LS3 Integrated Access System Hardware Installation and Configuration

This document provides instructions for installing the Cisco AccessPath-LS3 Integrated Access System. The system consists of individual components and a set of cables. The instructions are for the integrated system, for additional information about the individual system components, see the documents listed in the “Related and Referenced Documents” section.

This document contains the following sections:

- Related and Referenced Documents, page 1
- Cisco AccessPath-LS3 Integrated Access System Product Overview, page 2
- Preparing for Installation, page 7
- Installing the AccessPath-LS3 Components, page 15
- Federal Communications Commission (FCC) Statement, page 23
- Cisco Connection Online, page 24

Related and Referenced Documents



Timesaver Make sure that you have access to the following documents. These documents are available in print, on CD-ROM, and on the World Wide Web. If you need further assistance, see the section, “Cisco Connection Online.”

Table 1 Related and Referenced Documents

Cisco Product	Document Title
Cisco AccessPath-LS3 Integrated Access System ¹	• <i>Cisco AccessPath-LS3 Integrated Access System Software Configuration</i>
	• <i>Regulatory Compliance and Safety Information for the Cisco AccessPath-LS3 Integrated Access System</i>
	• <i>Cisco AccessPath Manager 1.1 CD-ROM Booklet</i>

Corporate Headquarters
Cisco Systems, Inc.
170 West Tasman Drive
San Jose, CA 95134-1706
USA

Copyright © 1997
Cisco Systems, Inc.
All rights reserved.

Table 1 **Related and Referenced Documents (Continued)**

Cisco Product	Document Title
Access Server Shelves ^{1, 2}	<ul style="list-style-type: none">• <i>Cisco AS5300 Universal Access Server Software Configuration Guide</i>• <i>Cisco AS5300 Universal Access Server Hardware Installation Guide</i>
Console Router Shelf ^{1, 2}	<ul style="list-style-type: none">• <i>Cisco 3640 Router Installation and Configuration Guide</i>
Switch Shelf ^{1, 2}	<ul style="list-style-type: none">• <i>FastHub 216T Installation and Configuration Guide</i>
Cisco IOS Software ²	<ul style="list-style-type: none">• <i>Configuration Fundamentals Configuration Guide</i> <p>In addition, refer to the applicable configuration guide, command reference, and associated publications (e.g., feature guides, release notes, configuration notes, updates).</p>
Cisco Marketing Tools	<ul style="list-style-type: none">• <i>Cisco Information Packet</i>• <i>Cisco Product Catalog</i>

1. See also any applicable configuration notes, updates, and release notes.

2. These documents are not shipped in printed format with the Cisco AccessPath-LS3 Integrated Access System. They are, however, available on the Cisco Connection Documentation CD-ROM, the World Wide Web, or you can order printed manuals (see the section "Cisco Connection Online" for ordering information).

Cisco AccessPath-LS3 Integrated Access System Product Overview

The Cisco AccessPath-LS3 Integrated Access System is a scalable, high-density dial system designed to terminate a number of mixed digital and analog calls. The AccessPath-LS3 system provides dial access for service providers or an Enterprise deploying small to medium-scale hybrid access ports at a central or distributed site. It supports remote node or remote local-area network (LAN) applications using either asynchronous modem or Integrated Services Digital Network (ISDN) technology and includes the latest access server, switching, and high-end routing features available with Cisco IOS software.

The AccessPath-LS3 system integrates access servers and a high-end router that can be mounted in a single Electronic Industries Association (EIA)-standard rack cabinet. It can terminate either analog modem or digital ISDN for all of the incoming lines. Processing tasks—such as answering and terminating calls—are divided among several CPUs, increasing overall system call processing and throughput performance.

The Cisco AccessPath-LS3 Integrated Access System provides scalable dial-port counts and high-performance backbone routing in a distributed system architecture designed for the reliability and serviceability demanded by point-of-presence (POP) administrators who want to minimize downtime and service costs. Figure 1 shows the AccessPath-LS3 system with four access server shelves.

Figure 1 AccessPath-LS3 Configured with Four Access Server Shelves

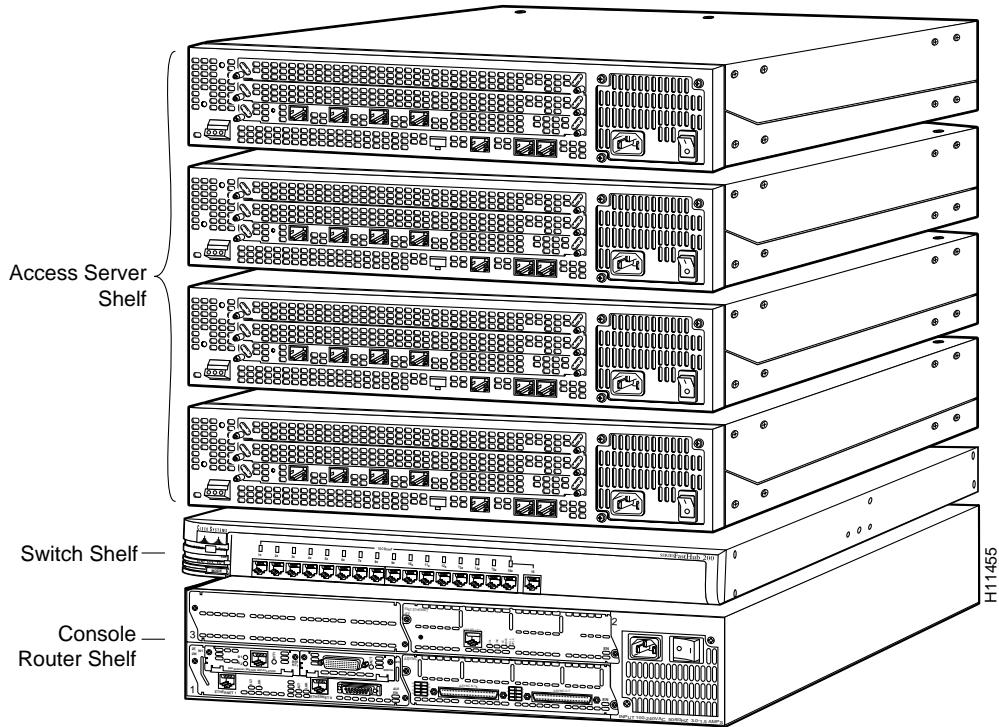
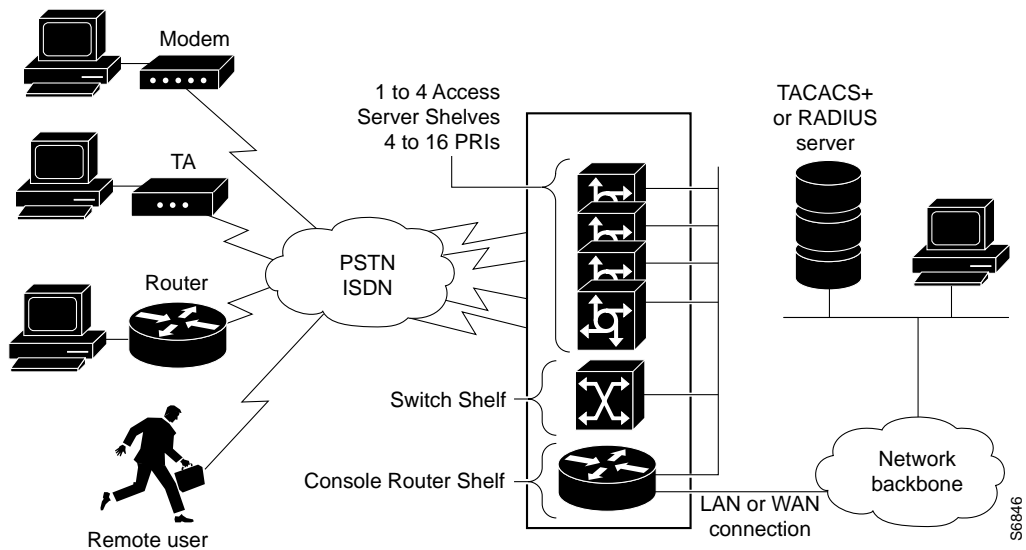

Figure 2 illustrates a typical AccessPath-LS3 stack environment.

Figure 2 AccessPath-LS3 Stack Environment



Introduction to the Cisco AccessPath-LS3 System Features

T1 or E1 lines, supporting either ISDN Primary Rate Interface (PRI) or channel-associated signaling (CAS), feed into the AccessPath-LS3 system's Access Server Shelves. Each Access Server Shelf has four lines. With a maximum configuration of four Access Server Shelves, the AccessPath-LS3 system can accommodate up to 16 T1 or E1 connections.

For example, an Access Server Shelf has four lines. In a T1 Primary Rate Interface (PRI) configuration, each of these lines can handle 23 calls (23B+D). The maximum configuration of four Access Server Shelves provides a maximum capacity of 368 ISDN 1B+D BRI calls. The calls are terminated, aggregated, and multiplexed in the Access Server Shelf, then sent over a 100BaseT Fast Ethernet connection to the Console Router Shelf.

Figure 3 illustrates call pathways through the AccessPath-LS3 system.

Figure 3 Call Pathways Through the AccessPath-LS3 System

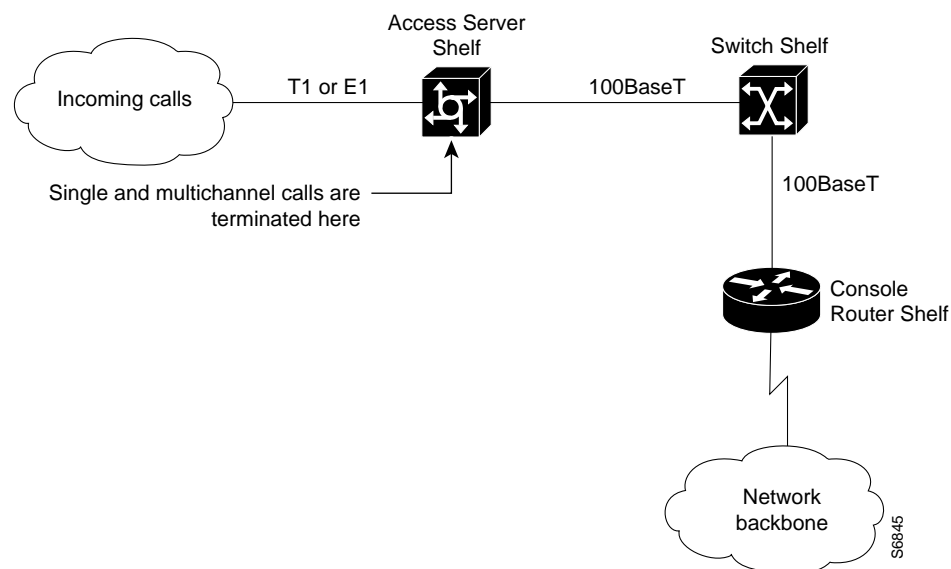

The Cisco AccessPath-LS3 Integrated Access System supports the following features:

- 100 Mbits/sec data backplane.
- Out-of-band device management using optional dialup or local terminal access.
- Cisco level 2 forwarding (L2F).
- Multichassis multilink PPP (MMP).
- Full Cisco IOS IP+ functionality (Cisco IOS Release 11.2(10) or later).
- T1/E1 and Ethernet backhaul interface support (10 Mbs or 100 Mbs).
- Automatic sensing of both analog modem and digital ISDN calls across the entire rotary, regardless of size.
- From 4 to 16 T1 Primary Rate Interface (PRI) lines with integrated CSUs terminated in a single AccessPath-LS3 system. This allows up to 368 simultaneous ISDN 1B+D BRI calls to be terminated in a single T1-configured AccessPath-LS3 system.

- Full management of all components including access servers and their modems and routers using the Simple Network Management Protocol (SNMP) management information bases (MIBs) with RMON on a 100 MB backplane or the AccessPath Manager software when the Console Router Shelf is configured with an optional 16-port asynchronous module.
- Full management of all components via a single management interface when using the AccessPath Manager software when the Console Router Shelf is configured with an optional 16-port asynchronous module. Parameters and statistics gathered across all the dial interfaces of the Cisco AccessPath-LS3 Integrated Access System are in one place.

Physical Specifications

The AccessPath-LS3 system consists of the following components that can be mounted in your own rack system:

- 1 to 4 Access Server Shelves (Cisco AS5300)
- 1 Console Router Shelf (Cisco 3640)
- 1 Switch Shelf (FastHub 216T)

Access Server Shelves

Each Access Server Shelf consists of the Cisco AS5300 universal access server, a versatile data communications platform that provides the functions of an access server, router, and digital modems in a single modular chassis. The access server is intended for Internet service providers (ISPs), telecommunications carriers, and other service providers that offer managed Internet connections, and also medium- to large-sized sites that provide both digital and analog access to users on an enterprise network. By terminating both analog and digital calls on the same chassis simultaneously, the access server provides you with a clear, simple, and easy migration path from today's analog dial access services to tomorrow's digital dial access services.

The access server consists of the following components:

- One 19-in. modular chassis with a high-speed backplane and three slots for a variety of feature cards
- Quad T1/Primary Rate Interface (PRI) or quad E1/PRI feature cards
- MICA carrier cards or Microcom carrier cards with modems
- Two Ethernet LAN (RJ-45) ports: 10BaseT and 10BaseT/100BaseT selectable
- One console port for local administrative access
- One auxiliary port for remote administrative access
- An integral AC power supply

Console Router Shelf

The features of the Console Router Shelf (Cisco 3640) include:

- High-performance, 100-MHz Reduced Instruction Set Computer (RISC) processor
- Four slots for port modules
- Optional 16-port asynchronous module with 2 octal cables
- Two slots for Personal Computer Memory Card International Association (PCMCIA) cards

- Flash memory capability
- Support for Cisco Redundant Power System (RPS)
- Four slots for dynamic random-access memory (DRAM), user-configurable as shared memory or main (processor) memory
- Support for connection to an optional external redundant power supply
- High-speed console and auxiliary ports (up to 115.2 kbps)
- Hardware thermal alarm to warn of excessively high operating temperature
- Can be installed in a 19-, 23-, or 24-inch rack, on a wall, or on a desk

The chassis includes four slots in which you can install modules. You can install any module into any available slot in the chassis. The slots are numbered from 0 to 3, as follows:

- Slot 0 is at the bottom right (as viewed from the rear of the chassis), near the power supply.
- Slot 1 is at the bottom left.
- Slot 2 is at the top right, above slot 0.
- Slot 3 is at the top left, above slot 1.

Switch Shelf

The Switch Shelf (FastHub 216T) is a managed 16-port 100BaseT Class II repeater for workgroups and server farms. It is a member of an extended network system of stackable, modular LAN and WAN products that increase LAN performance, connect remote offices and users, and provide secure access.

The Switch Shelf has 16 fixed 100BaseTX ports (with an alternative uplink port for connecting to other 100BaseTX hubs).

Table 2 summarizes the features of the Switch Shelf.

Table 2 **Switch Shelf Feature Summary**

Feature	Description
Compatibility	IEEE 802.3u Class II repeater compliant. Compatible with the 100BaseT standard for interoperability with other 100BaseT products.
Performance	100-Mbps peak and aggregate throughput.
Manageability	Network management for port configuration and status. Supports Simple Network Management Protocol (SNMP), Telnet, terminal-based out-of-band management, and Remote Monitoring (RMON) for management and troubleshooting. Manageable by CiscoWorks and other SNMP-compatible management systems on a per port and per unit basis. Each port has a multifunction LED that shows link integrity, receive activity, and port enabled or disabled status. Bandwidth utilization for the Switch Shelf is also shown through the port LEDs. A group collision LED shows collisions for all ports on the Switch Shelf.
Redundancy	Supports connection to the optional Cisco Redundant Power System (RPS).

Note Network management is built into the main board of the FastHub 216T.

Preparing for Installation

Before installing your Cisco AccessPath-LS3 Integrated Access System, you should consider the power and cabling requirements that must be in place at your installation site, the equipment you will need to install the system, and the environmental conditions your installation site must meet to maintain normal operation. This section guides you through the process of preparing for your Cisco AccessPath-LS3 Integrated Access System installation.

Safety Recommendations

The following statements are general safety guidelines for use when working with the Cisco AccessPath-LS3 Integrated Access System.

- The installation of your Cisco AccessPath-LS3 Integrated Access System should be in compliance with national and local electrical codes. In the United States, National Fire Protection Association (NFPA) 70, United States National Electrical Code. In Canada, Canadian Electrical Code, part I, CC22.1. In other countries, International Electrotechnical Commission (IEC) 364, part 1 through part 7.
- Review the safety warnings listed in the publication *Regulatory Compliance and Safety Information for the Cisco AccessPath-LS3 Integrated Access System* before installing, configuring, troubleshooting, or maintaining the AccessPath-LS3 system.
- Read the installation instructions before you connect the system to its power source.
- Never attempt to lift an object that might be too heavy for one person to lift alone.
- Always turn all power supplies off (O) and unplug all power cables for an AccessPath-LS3 system shelf before opening it.
- Keep the area clear and dust free during and after installation.
- Keep tools and chassis components away from walk areas.
- Do not wear loose clothing, jewelry (including rings and chains), or other items that could get caught in the chassis. Fasten your tie or scarf and roll up your sleeves.
- The Cisco AccessPath-LS3 Integrated Access System operates safely when it is used in accordance with its marked electrical ratings and product usage instructions.
- This product is intended for installation in a restricted access area. A restricted access area is where access can only be gained by service personnel through the use of a special tool, or lock and key, or other means of security, and is controlled by the authority responsible for the location.
- Secure all power cabling when installing these components to avoid disturbing field-wiring connections.
- This equipment is intended to be grounded. Ensure that each component is connected to earth ground during normal use.
- Network hazardous voltages are present in the T1 PRI cable. If you detach the cable, detach the end away from the access server first to avoid possible electric shock. Network hazardous voltages are also present in the area of the T1 PRI (RJ-48C) ports, regardless of whether power is off or on.
- Do not work on the system or connect or disconnect cables during periods of lightning activity.
- Do not touch the power supply when the power cord is connected. For systems with a power switch, line voltages are present within the power supply even when the power switch is off and the power cord is connected. For systems without a power switch, line voltages are present within the power supply when the power cord is connected.

- To prevent bodily injury when mounting or servicing these components in a rack, you must take special precautions to ensure that the system remains stable. The following guidelines are provided to ensure your safety:
 - This unit should be mounted at the bottom of the rack if it is the only unit in the rack.
 - When mounting this unit in a partially filled rack, load the rack from the bottom to the top with the heaviest component at the bottom of the rack.
 - If the rack is provided with stabilizing devices, install the stabilizers before mounting or servicing the unit in the rack.
- The ports labeled “Ethernet,” “10BaseT,” “Token Ring,” “Console,” and “AUX” are safety extra-low voltage (SELV) circuits. SELV circuits should only be connected to other SELV circuits. Because the BRI circuits are treated like telephone-network voltage, avoid connecting the SELV circuit to the telephone network voltage (TNV) circuits.
- Only trained and qualified personnel should be allowed to install or replace this equipment.
- Before working on equipment that is connected to power lines, remove jewelry (including rings, necklaces, and watches). Metal objects will heat up when connected to power and ground and can cause serious burns or weld the metal object to the terminals.

Warning Statements



Warning Means danger. You are in a situation that could cause bodily injury. Before you work on any equipment, be aware of the hazards involved with electrical circuitry and be familiar with standard practices for preventing accidents. To see translations of the warnings that appear in this publication, refer to the *Regulatory Compliance and Safety Information* document that accompanied this device.

Waarschuwing Dit waarschuwingssymbool betekent gevaar. U verkeert in een situatie die lichamelijk letsel kan veroorzaken. Voordat u aan enige apparatuur gaat werken, dient u zich bewust te zijn van de bij elektrische schakelingen betrokken risico's en dient u op de hoogte te zijn van standaard maatregelen om ongelukken te voorkomen. Voor vertalingen van de waarschuwingen die in deze publicatie verschijnen, kunt u het document *Regulatory Compliance and Safety Information* (Informatie over naleving van veiligheids- en andere voorschriften) raadplegen dat bij dit toestel is ingesloten.

Varoitus Tämä varoitusmerkki merkitsee vaaraa. Olet tilanteessa, joka voi johtaa ruumiinvammaan. Ennen kuin työskentelet minkään laitteiston parissa, ota selvää sähkökytkentöihin liittyvistä vaaroista ja tavanomaisista onnettomuuksien ehkäisykeinoista. Tässä julkaisussa esiintyvien varoitusten käännökset löydät laitteen mukana olevasta *Regulatory Compliance and Safety Information* -kirjasesta (määräysten noudattaminen ja tietoa turvallisuudesta).

Attention Ce symbole d'avertissement indique un danger. Vous vous trouvez dans une situation pouvant causer des blessures ou des dommages corporels. Avant de travailler sur un équipement, soyez conscient des dangers posés par les circuits électriques et familiarisez-vous avec les procédures couramment utilisées pour éviter les accidents. Pour prendre connaissance des traductions d'avertissements figurant dans cette publication, consultez le document *Regulatory Compliance and Safety Information* (Conformité aux règlements et consignes de sécurité) qui accompagne cet appareil.

Warnung Dieses Warnsymbol bedeutet Gefahr. Sie befinden sich in einer Situation, die zu einer Körperverletzung führen könnte. Bevor Sie mit der Arbeit an irgendeinem Gerät beginnen, seien Sie sich der mit elektrischen Stromkreisen verbundenen Gefahren und der Standardpraktiken zur

Vermeidung von Unfällen bewußt. Übersetzungen der in dieser Veröffentlichung enthaltenen Warnhinweise finden Sie im Dokument *Regulatory Compliance and Safety Information* (Informationen zu behördlichen Vorschriften und Sicherheit), das zusammen mit diesem Gerät geliefert wurde.

Avvertenza Questo simbolo di avvertenza indica un pericolo. La situazione potrebbe causare infortuni alle persone. Prima di lavorare su qualsiasi apparecchiatura, occorre conoscere i pericoli relativi ai circuiti elettrici ed essere al corrente delle pratiche standard per la prevenzione di incidenti. La traduzione delle avvertenze riportate in questa pubblicazione si trova nel documento *Regulatory Compliance and Safety Information* (Conformità alle norme e informazioni sulla sicurezza) che accompagna questo dispositivo.

Advarsel Dette varselsymbolet betyr fare. Du befinner deg i en situasjon som kan føre til personskade. Før du utfører arbeid på utstyr, må du være oppmerksom på de faremomentene som elektriske kretser innebærer, samt gjøre deg kjent med vanlig praksis når det gjelder å unngå ulykker. Hvis du vil se oversettelser av de advarslene som finnes i denne publikasjonen, kan du se i dokumentet *Regulatory Compliance and Safety Information* (Overholdelse av forskrifter og sikkerhetsinformasjon) som ble levert med denne enheten.

Aviso Este símbolo de aviso indica perigo. Encontra-se numa situação que lhe poderá causar danos físicos. Antes de começar a trabalhar com qualquer equipamento, familiarize-se com os perigos relacionados com circuitos eléctricos, e com quaisquer práticas comuns que possam prevenir possíveis acidentes. Para ver as traduções dos avisos que constam desta publicação, consulte o documento *Regulatory Compliance and Safety Information* (Informação de Segurança e Disposições Reguladoras) que acompanha este dispositivo.

¡Advertencia! Este símbolo de aviso significa peligro. Existe riesgo para su integridad física. Antes de manipular cualquier equipo, considerar los riesgos que entraña la corriente eléctrica y familiarizarse con los procedimientos estándar de prevención de accidentes. Para ver una traducción de las advertencias que aparecen en esta publicación, consultar el documento titulado *Regulatory Compliance and Safety Information* (Información sobre seguridad y conformidad con las disposiciones reglamentarias) que se acompaña con este dispositivo.

Warning! Denna varningssymbol signalerar fara. Du befinner dig i en situation som kan leda till personskada. Innan du utför arbete på någon utrustning måste du vara medveten om farorna med elkretsar och känna till vanligt förfarande för att förebygga skador. Se förklaringar av de varningar som förekommer i denna publikation i dokumentet *Regulatory Compliance and Safety Information* (Efterrettelse av föreskrifter och säkerhetsinformation), vilket medföljer denna anordning.

Safety with Electricity

Follow these guidelines when working on equipment powered by electricity:



Warning Before working on equipment that is connected to power lines, remove jewelry (including rings, necklaces, and watches). Metal objects will heat up when connected to power and ground and can cause serious burns or weld the metal object to the terminals.

- Locate the emergency power-OFF switch in the room in which you are working. Then, if an electrical accident occurs, you can quickly turn OFF the power.

- Disconnect all power before doing the following:

- Installing or removing a chassis
- Working near power supplies



Warning Before working on a chassis or working near power supplies, unplug the power cord on AC units; disconnect the power at the circuit breaker on DC units.



Warning Do not touch the power supply when the power cord is connected. For systems with a power switch, line voltages are present within the power supply even when the power switch is off and the power cord is connected. For systems without a power switch, line voltages are present within the power supply when the power cord is connected.

- For systems without a power switch, line voltages are present within the power supply when the power cord is connected.



Warning This equipment is intended to be grounded. Ensure that the host is connected to earth ground during normal use.



Warning When installing the unit, the ground connection must always be made first and disconnected last.

- Do not work alone if hazardous conditions exist.
- Never assume that power is disconnected from a circuit. Always check.



Warning Read the installation instructions before you connect the system to its power source.



Warning To avoid electric shock, do not connect safety extra-low voltage (SELV) circuits to telephone-network voltage (TNV) circuits. LAN ports contain SELV circuits, and WAN ports contain TNV circuits. Some LAN and WAN ports both use RJ-45 connectors. Use caution when connecting cables.



Warning Hazardous network voltages are present in WAN ports regardless of whether power to the router is OFF or ON. To avoid electric shock, use caution when working near WAN ports. When detaching cables, detach the end away from the router first.

- Look carefully for possible hazards in your work area, such as moist floors, ungrounded power extension cables, frayed power cords, and missing safety grounds.
- If an electrical accident occurs, proceed as follows:
 - Use caution; do not become a victim yourself.
 - Turn OFF power to the device.
 - If possible, send another person to get medical aid. Otherwise, assess the victim's condition and then call for help.

- Determine if the person needs rescue breathing or external cardiac compressions; then take appropriate action.

In addition, use the following guidelines when working with any equipment that is disconnected from a power source, but still connected to telephone wiring or other network cabling:

- Never install telephone wiring during a lightning storm.
- Never install telephone jacks in wet locations unless the jack is specifically designed for it.
- Never touch uninsulated telephone wires or terminals unless the telephone line is disconnected at the network interface.
- Use caution when installing or modifying telephone lines.



Warning Only trained and qualified personnel should be allowed to install or replace this equipment.

Preventing Electrostatic Discharge Damage

Electrostatic discharge (ESD) can damage equipment and impair electrical circuitry. It can occur if electronic printed circuit cards are improperly handled and can cause complete or intermittent failures. Always follow ESD prevention procedures when removing and replacing modules:

- Ensure that the router chassis is electrically connected to earth ground.
- Wear an ESD-preventive wrist strap, ensuring that it makes good skin contact. Connect the clip to an unpainted surface of the chassis frame to channel unwanted ESD voltages safely to ground. To guard against ESD damage and shocks, the wrist strap and cord must operate effectively.
- If no wrist strap is available, ground yourself by touching a metal part of the chassis.



Caution For the safety of your equipment, periodically check the resistance value of the antistatic strap. It should be from 1 to 10 megohm (Mohm).

Power Supply Considerations

Check the power at your site to ensure that you are receiving “clean” power (free of spikes and noise). Install a power conditioner if necessary.



Warning The device is designed to work with TN power systems.



Warning Do not work on the system or connect or disconnect cables during periods of lightning activity.



Warning This unit has more than one power cord. To reduce the risk of electric shock, disconnect the three to five power supply cords before servicing the unit.

Note Each AccessPath-LS3 component should be connected to its own circuit to ensure sufficient operational power.

The AC power supply on each component has the following characteristics:

- Autoranging, 100 to 240 VAC, 2.0 to 7.0A, 50 to 60 Hz
- 6-ft (1.8-m) electrical power cord

Preventive Site Configuration

The following precautions will help you plan an acceptable operating environment for your AccessPath-LS3 system components and will help you avoid environmentally caused equipment failures:

- Remember that electrical equipment generates heat. Ambient air temperature may not cool equipment to acceptable operating temperatures without adequate circulation. Ensure that the room where your equipment operates has adequate circulation.
- Always follow the ESD prevention procedures in the section “Preventing Electrostatic Discharge Damage” earlier in this document to avoid damage to equipment. Damage from static discharge can cause immediate or intermittent equipment failure.
- Ensure that the chassis cover and module rear panels are secure. All empty module slots and WAN interface card slots must have filler panels installed. The chassis is designed to allow cooling air to flow within it, through specially designed cooling slots. A chassis with uncovered openings will create air leaks, which may interrupt and reduce the airflow across internal components.

Site Environment

Table 3 lists the operating and nonoperating environmental site requirements. The following ranges are those within which the Cisco AccessPath-LS3 Integrated Access System will continue to operate; however, a measurement that is approaching the minimum or maximum of a range indicates a potential problem. You can maintain normal operation by anticipating and correcting environmental anomalies before they approach a maximum operating range.

- Operating temperature range: 32 to 104 F (0 to 40 C).
- Operating humidity range: 10 to 90%, noncondensing.
- Airflow: Cooling air is drawn in through air intake vents on the right side and back of the chassis (when viewing the AccessPath-LS3 system from the front) and is exhausted through the left side and front of the chassis. Keep the AccessPath-LS3 system clear of obstructions and away from the exhaust of other equipment.

Table 3 Specifications for Operating and Nonoperating Environments

Specification	Minimum	Maximum
Temperature, ambient operating	32 F (0 C)	104 F (40 C)
Temperature, ambient nonoperating and storage	-4 F (-20 C)	149 F (65 C)
Humidity, ambient (noncondensing) operating	10%	90%
Humidity, ambient (noncondensing) nonoperating and storage	5%	95%
Altitude, operating and nonoperating	Sea level (0 ft. (0 m))	10,000 ft (3050 m)
Vibration, operating	5 to 200 Hz, 0.5 g (1 oct/min)	—
Vibration, nonoperating	5 to 200 Hz, 1 g (1 oct/min) 200 to 500 Hz, 2 g (1 oct/min)	—



Warning This unit is intended for installation in restricted access areas. A restricted access area is where access can only be gained by service personnel through the use of a special tool, lock and key, or other means of security, and is controlled by the authority responsible for the location.

Equipment Racks

You can mount the AccessPath-LS3 components in a 19-, 23-, or 24-inch equipment rack. The following information will help you plan your equipment rack configuration:

- Enclosed racks must have adequate ventilation. Ensure that the rack is not congested, because each unit generates heat. An enclosed rack should have louvered sides and a fan to provide cooling air. Heat generated by equipment near the bottom of the rack can be drawn upward into the intake ports of the equipment above.
- When mounting a chassis in an open rack, ensure that the rack frame does not block the intake or exhaust ports.
- If the chassis is installed on slides, check the position of the chassis when it is seated into the rack.
- Baffles can isolate exhaust air from intake air, which also helps to draw cooling air through the chassis. The best placement of the baffles depends on the airflow patterns in the rack, which can be found by experimenting with different configurations.
- When equipment installed in a rack (particularly in an enclosed rack) fails, try operating the equipment by itself, if possible. Power off other equipment in the rack (and in adjacent racks) to allow the unit under test a maximum of cooling air and clean power.



Warning To prevent bodily injury when mounting or servicing this unit in a rack, you must take special precautions to ensure that the system remains stable. The following guidelines are provided to ensure your safety:

- This unit should be mounted at the bottom of the rack if it is the only unit in the rack.
- When mounting this unit in a partially filled rack, load the rack from the bottom to the top with the heaviest component at the bottom of the rack.
- If the rack is provided with stabilizing devices, install the stabilizers before mounting or servicing the unit in the rack.

Tools for Installation

Each of the AccessPath-LS3 components must be unpacked and mounted in a rack that you supply. Therefore, you may need some or all of the following to complete the installation:

- ESD-preventive wrist straps for each person
- Number 2 Phillips screwdriver
- 3/16-inch flat-blade screwdriver
- Tape measure (optional)
- Level (optional)

In addition, you might need the following external equipment:

- To connect a serial port to a T1 network, you need a T1 channel service unit/data service unit (CSU/DSU) that converts the High-Level Data Link Control (HDLC) synchronous serial data stream into a T1 data stream with the correct framing and ones density. (Some telephone systems require a minimum number of 1 bits per time unit in a data stream, called ones density.) Several T1 CSU/DSU devices are available as additional equipment, and most provide either a V.35, EIA/TIA-449, or EIA-530 electrical interface.
- To connect an Ethernet port to your local network, you need an RJ-45 to RJ-45 cable.



Warning Ultimate disposal of this product should be handled according to all national laws and regulations.

Installing the AccessPath-LS3 Components

Before you can install the AccessPath-LS3 components you must unpack each box. Verify that all of the components listed on the packing slip that came with your order are present.

Inspecting the Equipment

Do not unpack the equipment until you are ready to install it. If the final installation site will not be ready for some time, keep the components in the shipping containers to prevent accidental damage. When you are ready to install the system, proceed with the unpacking.

The routers, cables, publications, and any optional equipment you ordered may be shipped in more than one container.

When you unpack the containers, check the packing list to ensure that you received all the following items:

- 1 Console Router Shelf (Cisco 3640 may contain an optional 16 port asynchronous module and 2 octal cables)
- 1 to 4 Access Server Shelves (Cisco AS5300) (depending on how many you ordered)
- 1 Switch Shelf (FastHub 216T)
- Up to six 6-foot (1.8-meter) power cords, one for each component
- Rubber feet for desktop mounting
- Rack-mount brackets for all components
- Console and auxiliary cabling kit (one RJ-45 rollover cable, one RJ-45-to-DB-9 terminal adapter, one RJ-45-to-DB-25 modem adapter, and one RJ-45-to-DB-25 terminal adapter) for each component
- Optional equipment (such as network connection cables, additional port modules, or additional rack-mount brackets)
- Packet of labels for cables
- 5 Ethernet RJ-45 to RJ-45 straight-through cables (6-foot length (1.8-meter))
- This publication, the *Cisco AccessPath-LS3 Integrated Access System Software Configuration* document, the *Cisco AccessPath-LS3 Integrated Access System Regulatory Compliance and Safety Information* document, the CD-ROM with AccessPath-LS3 sample configurations, the documentation CD-ROM, and optional companion publications as specified in your order
- Information packet publication

Inspect all items for shipping damage. If anything appears to be damaged, or if you encounter problems installing or configuring your components, contact customer service. Warranty, service, and support information is in the information packet that shipped with your equipment.

Labeling the Cables

The Cisco AccessPath-LS3 Integrated Access System comes with five RJ-45 to RJ-45 straight-through Ethernet cables, two octal cables (optional with 16-port asynchronous module), and a package of labels. A label should be affixed to each end of each of the enclosed cables.

The 28 labels are marked as follows:

- 1 each AS01-FE0, AS02-FE0, AS03-FE0, AS04-FE0
- 1 CRS01-FE2/0
- 1 each FHUB-ETH01, FHUB-ETH02, FHUB-ETH03, FHUB-ETH04
- 1 FHUB-ETH16
- 1 each ASYNC 0-7, ASYNC 8-15
- 1 each AS01-CON, AS02-CON, AS03-CON, AS04-CON
- 1 FHUB-CON
- 11 labels marked SPARE

To affix the labels to an AccessPath-LS3 with 4 Access Server Shelves, follow these steps:

- Step 1** On the first RJ-45 to RJ-45 cable, place the AS01-FE0 label on one end and the FHUB-ETH01 label on the other end. (See Figure 4.)
- Step 2** On the second RJ-45 to RJ-45 cable, place the AS02-FE0 label on one end and the FHUB-ETH02 label on the other end.
- Step 3** Repeat Step 2 on the next two RJ-45 to RJ-45 cables.
- Step 4** On the last cable, place the CRS01-FE2/0 label on one end and the FHUB-ETH16 label on the other end.

Figure 4 RJ-45 to RJ-45 Cables with Labels

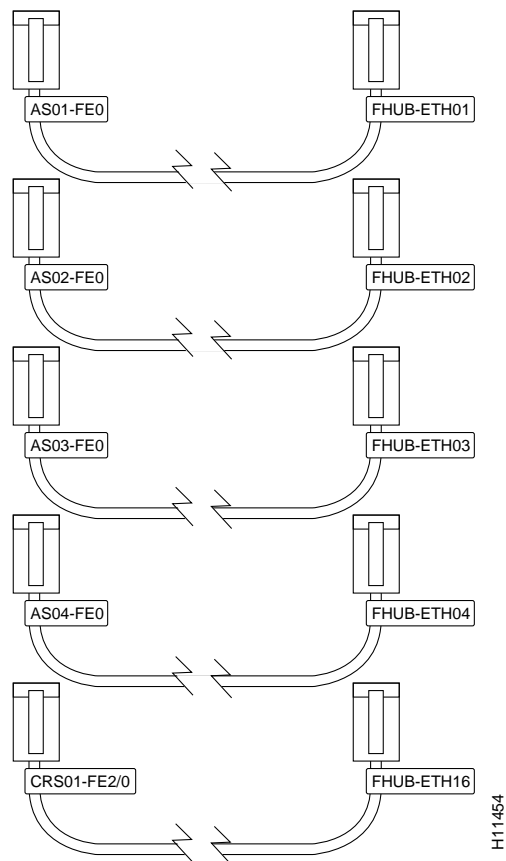

H11454

Step 5 Set the RJ-45 to RJ-45 cables aside.

Note If you have the optional 16-port asynchronous module installed in the Console Router Shelf, continue with the next steps. If not, proceed to the next section “Rack-Mounting the Components.”

Step 6 On one octal cable, place the ASYNC 0-7 label on the end of the cable with the 68-pin connector.

Step 7 On the other octal cable, place the ASYNC 8-15 label on the end of the cable with the 68-pin connector.

Step 8 Place one of the following labels on the other end of each octal cable as shown in Table 4 and Figure 5:

Table 4 Octal Cable Labelling

Cable Number	Label
01	AS01-CON
02	AS02-CON
03	AS03-CON
04	AS04-CON
05-10	SPARE
11 (third cable in the second set)	FHUB-CON
12-16	SPARE

Figure 5 Octal Cable with Labels

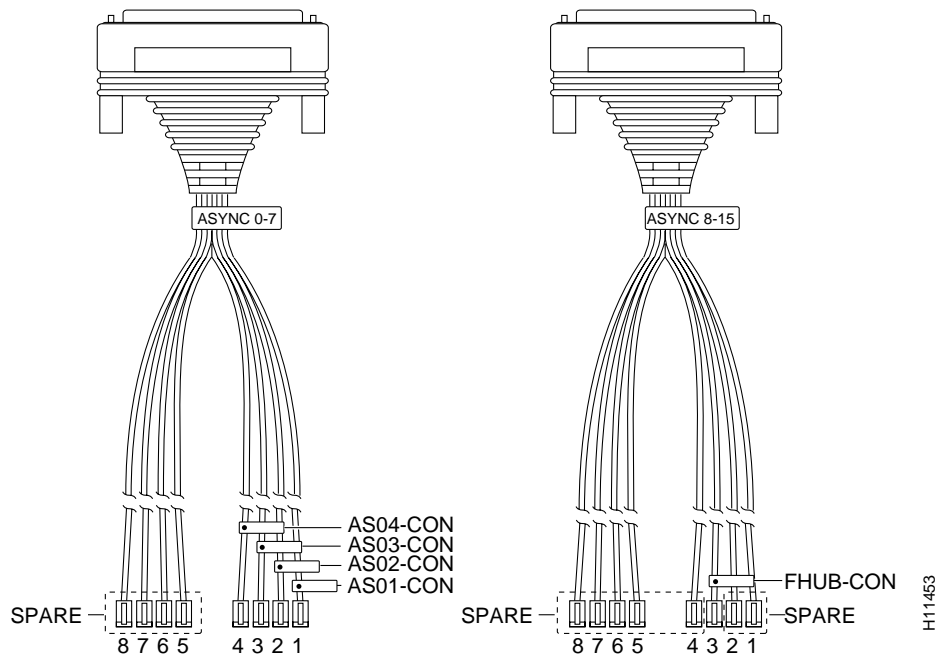

Rack-Mounting the Components

If you are planning to rack-mount the AccessPath-LS3 components, do so before making network and power connections. If you need to install modules or WAN interface cards, you can do so either before or after rack-mounting the components. Ideally, you would install modules or WAN interface cards when you have the best access to the router's rear panel.

Note You need a Number 2 Phillips screwdriver to mount the chassis in a rack.

Each component is shipped with one set of brackets. Brackets for 19-inch racks are shipped unless the 23- or 24-inch brackets are specified at the time of the order.

After the brackets are fastened to each chassis, you can rack-mount them. Using your own screws, attach each chassis to the rack as shown in Figure 6. Mount each chassis in the rack in the order shown in Figure 1.

Figure 6 Attaching the Access Server Chassis to the 19-Inch Rack—Rear Panel Forward

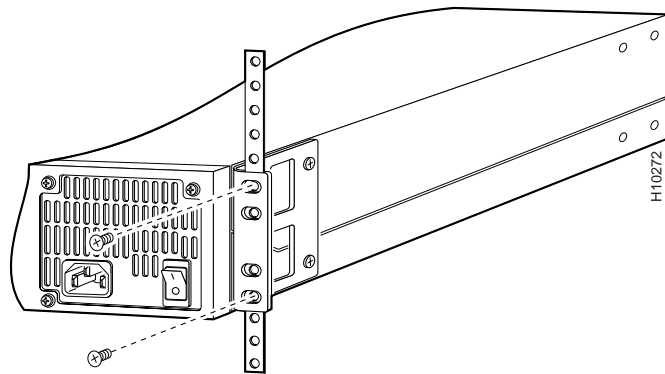

Note: The second bracket attaches to the rack at the other side of the chassis. The brackets can also be installed with the front panel forward.

Attaching the Interdevice Cables

You must connect three different types of cables in order to complete the assembly of the AccessPath-LS3 system, as follows:

- The Fast Ethernet port on each Access Server Shelf and the Console Router Shelf must be connected to the Switch Shelf using RJ-45 to RJ-45 straight-through cables.
- The console port on each Access Server Shelf and Switch Shelf must be connected to the Console Router Shelf using the included octal cables (optional).
- After the internal cabling is completed, a terminal must be connected to the console port on the Console Router Shelf to complete the software configuration of your AccessPath-LS3 system.

Note If you do not have the optional 16-port asynchronous module installed in the Console Router Shelf, you must connect the console to each component to complete the software configuration.

Connecting the Ethernet Ports on the Access Server Shelves

To connect the Access Server Shelves to the network, follow these steps:

- Step 1** Each of the Access Server Shelves is connected to an Ethernet network by connecting the 100BaseT port to the corresponding port on the Switch Shelf. Connect each of the Access Server Shelves to the specified port on the Switch Shelf using the appropriate RJ-45 cable (see Figure 7).

Figure 7 Connecting Each Access Server to the Switch Shelf

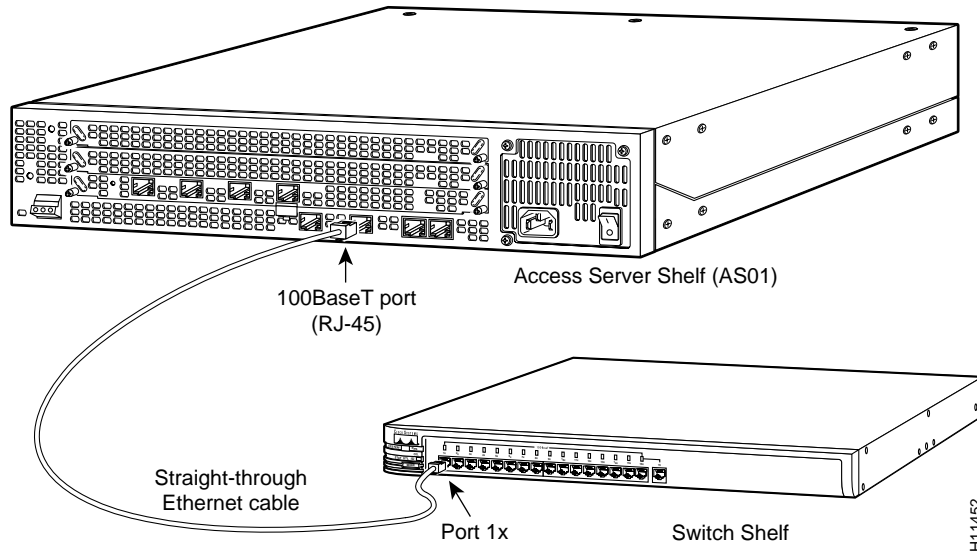

For example, connect the cable end labeled AS03-FE0 to the 100BaseT Ethernet port on the AS03 Access Server Shelf. Connect the other end of the cable, labeled FHUB-ETH03, to the 3x port on the Switch Shelf. Repeat this procedure until each of the access servers is connected to a port on the Switch Shelf.

- Step 2** Connect the cable labeled CRS01-FE2/0 to the Fast Ethernet port in slot 2 of the Console Router Shelf. Connect the other end of this cable, labeled FHUB-ETH16, to port 16x of the Switch Shelf, not port 16 (see Figure 8).

Figure 8 Connecting the Console Router Shelf to a 100BaseT Port on the Switch Shelf

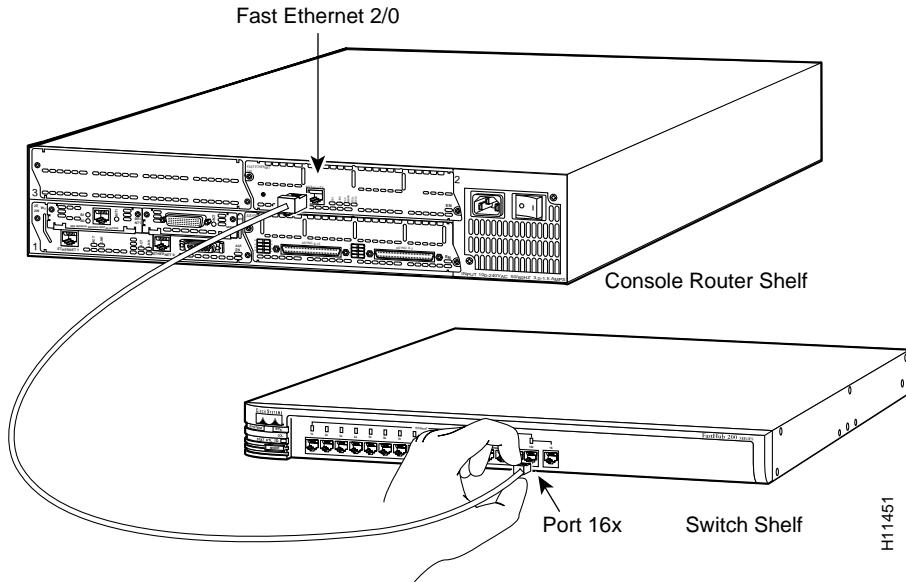

Caution You will disable both ports if you connect to both the uplink port (port 16) and port 16x.

Connecting the Console Ports to the Console Router Shelf (Optional)

If you have the optional 16-port asynchronous module installed in the Console Router Shelf, the console port on each of the Access Server Shelves and the Switch Shelf is connected to the Console Router Shelf using the labeled octal cable. This configuration allows you to access the console port on each AccessPath-LS3 component by connecting to one of the asynchronous ports on the Console Router Shelf (Cisco 3640).

Connect the labeled 68-pin side of each octal cable to the appropriate port on the Console Router Shelf. For example, the cable marked ASYNC 0-7 should be connected to the port marked 0-7 on the Console Router Shelf. Connect the other end of each octal cable as follows:

- Step 1** Connect the RJ-45 connector on the octal cable marked AS01-CON to the console port on AS01. (See Figure 9).

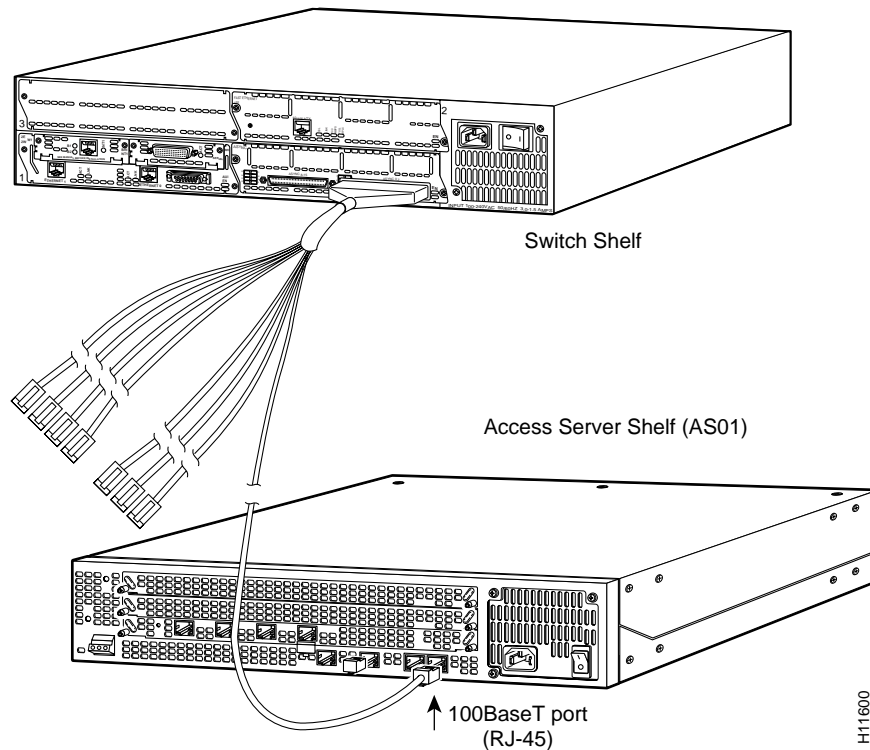
Figure 9 Connecting the Console Router Shelf to Each Access Server Shelf Console

- Step 2** Repeat Step 1 until each of the Access Server Shelf console port is connected to the Console Router Shelf.
- Step 3** Connect the RJ-45 connector on the octal cable marked FHUB-CON to the console port on the Switch Shelf (FastHub 216T).
- Step 4** Secure the cable connectors marked SPARE.

Connecting to the Console Port on the Console Router Shelf

Take the following steps to connect a local terminal (an ASCII terminal or a PC running terminal emulation software) to the console port on the Console Router Shelf (Cisco 3640):

- Step 1** Connect the terminal using one of the thin, flat, RJ-45-to-RJ-45 rollover cables (which look like telephone cables) and an RJ-45-to-DB-9 or RJ-45-to-DB-25 adapter (labeled “TERMINAL”) included with each of the components (see Figure 10).
- Step 2** Configure your terminal or PC terminal emulation software for 9600 baud, 8 data bits, no parity, and 1 stop bit.

Figure 10 Connecting the Console

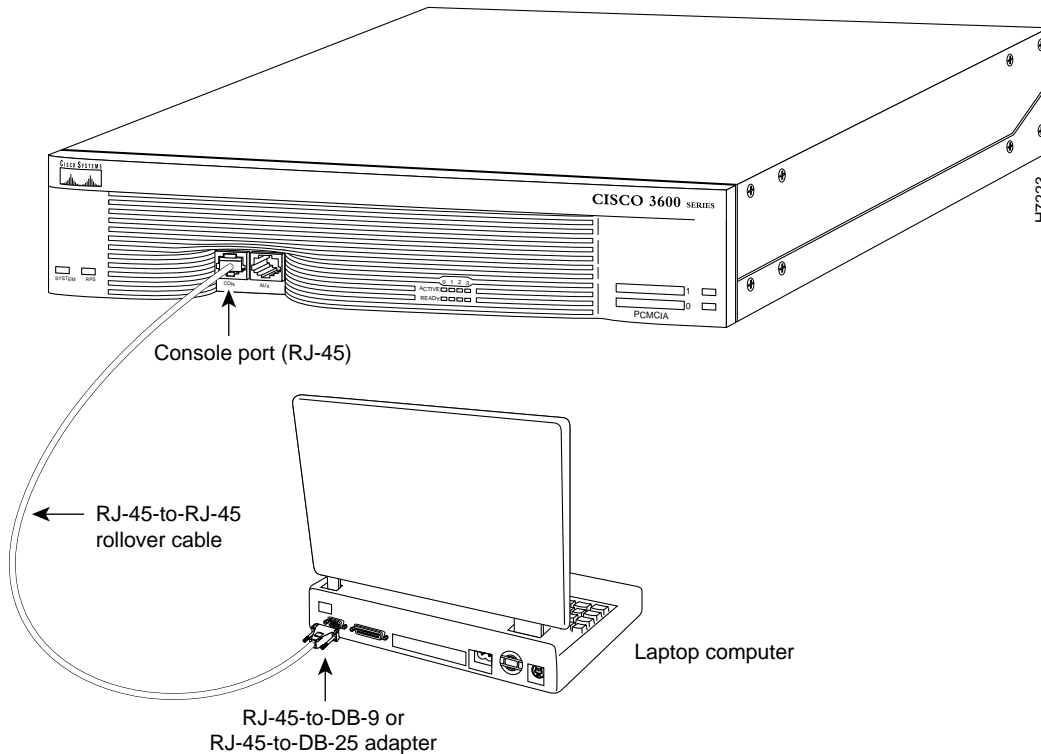

Step 3 Perform the same procedure on each of the AccessPath-LS3 components to complete the software configuration.

Attaching the Power Cables and Powering on the Components

To connect the power cords and power on each of the AccessPath-LS3 components, take these steps:

Step 1 Plug the power cord for each shelf into a 3-terminal, single-phase power source that provides power within the acceptable range (110 to 240 VAC, 50 to 60 Hz).



Warning This product relies on the building's installation for short-circuit (overcurrent) protection. Ensure that a fuse or circuit breaker no larger than 120 VAC, 15A U.S. (240 VAC, 10A international) is used on the phase conductors (all current-carrying conductors).

Step 2 Power ON the shelves. The LEDs labeled SYSTEM on the front or back panel should go on. The internal power supply fan should power on.



Warning Secure all power cabling when installing this unit to avoid disturbing field-wiring connections.

Connect to the Network Backbone

The Ethernet and Fast Ethernet interfaces on the Console Router Shelf are used to connect the Cisco AccessPath-LS3 Integrated Access System to a LAN. The synchronous serial and ISDN BRI interfaces on the Console Router Shelf are used to connect the AccessPath-LS3 system to a WAN.

The cables required to connect the router to a network are not provided with the router. However, cables and transceivers can be ordered from Cisco. For ordering information, see the section, “Cisco Connection Online” at the end of this document.

Refer to the *Cisco 3640 Router Installation and Configuration Guide* for detailed instructions on making connections to your LAN or WAN.

This completes the hardware installation. Refer to the *Cisco AccessPath-LS3 Integrated Access System Software Configuration* document for instructions on bringing the Cisco AccessPath-LS3 Integrated Access System online.

Federal Communications Commission (FCC) Statement

This equipment has been tested and found to comply with the limits for a Class B digital device, pursuant to Part 15 of the FCC Rules. These limits are designed to provide reasonable protection against harmful interference in a residential installation. This equipment generates, uses, and can radiate radio frequency energy and, if not installed and used in accordance with the instructions, may cause harmful interference to radio communications. However, there is no guarantee that interference will not occur in a particular installation. If this equipment does cause harmful interference to radio or television reception, which can be determined by turning the equipment off and on, the user is encouraged to try to correct the interference by one or more of the following measures:

- Reorient or relocate the receiving antenna.
- Increase the separation between the equipment and receiver.
- Connect the equipment into an outlet on a circuit different from that to which the receiver is connected.
- Consult the dealer or an experienced radio/TV technician for help.

Industry Canada Class B Emission Compliance Statement

This Class B digital apparatus meets the requirements of the Canadian Interference-Causing Equipment Regulations.

Avis De Conformite Aux Normes D'industrie Canada

Cet appareil numerique de la classe B respecte toutes les exigences du Reglement sur le materiel brouilleur du Canada.

European Union (EU) Statement

This product is in conformity with the protection requirements of EU Council Directive 89/336/EEC on the approximation of the laws of the Member States relating to electromagnetic compatibility. This company cannot accept responsibility for any failure to satisfy the protection requirements resulting from a non-recommended modification of the product, including the fitting of non-Cisco option cards.

This product has been tested and found to comply with the limits for Class B Information Technology Equipment according to CISPR 22 /European Standard EN 55022. The limits for Class B equipment were derived for typical residential environments to provide reasonable protection against interference with licensed communication devices.

Japanese Voluntary Control Council for Interference (VCCI) Statement

This is a Class B product based on the standard of the Voluntary Control Council for Interference from Information Technology Equipment (VCCI). If this is used near a radio or television receiver in a domestic environment, it may cause radio interference. Install and use the equipment according to the instruction manual.

Cisco Connection Online

Cisco Connection Online (CCO) is Cisco Systems' primary, real-time support channel. Maintenance customers and partners can self-register on CCO to obtain additional information and services.

Available 24 hours a day, 7 days a week, CCO provides a wealth of standard and value-added services to Cisco's customers and business partners. CCO services include product information, product documentation, software updates, release notes, technical tips, the Bug Navigator, configuration notes, brochures, descriptions of service offerings, and download access to public and authorized files.

CCO serves a wide variety of users through two interfaces that are updated and enhanced simultaneously: a character-based version and a multimedia version that resides on the World Wide Web (WWW). The character-based CCO supports Zmodem, Kermit, Xmodem, FTP, and Internet e-mail, and it is excellent for quick access to information over lower bandwidths. The WWW version of CCO provides richly formatted documents with photographs, figures, graphics, and video, as well as hyperlinks to related information.

You can access CCO in the following ways:

- WWW: <http://www.cisco.com>
- WWW: <http://www-europe.cisco.com>
- WWW: <http://www-china.cisco.com>
- Telnet: cco.cisco.com
- Modem: From North America, 408 526-8070; from Europe, 33 1 64 46 40 82. Use the following terminal settings: VT100 emulation; databits: 8; parity: none; stop bits: 1; and connection rates up to 28.8 kbps.

For a copy of CCO's Frequently Asked Questions (FAQ), contact cco-help@cisco.com. For additional information, contact cco-team@cisco.com.

Note If you are a network administrator and need personal technical assistance with a Cisco product that is under warranty or covered by a maintenance contract, contact Cisco's Technical Assistance Center (TAC) at 800 553-2447, 408 526-7209, or tac@cisco.com. To obtain general information about Cisco Systems, Cisco products, or upgrades, contact 800 553-6387, 408 526-7208, or cs-rep@cisco.com

This document is to be used in conjunction with the related and referenced documents identified in Table 1.

AccessPath, AtmDirector, Cache Director System, CD-PAC, Centri, Centri Bronze, Centri Gold, Centri Security Manager, Centri Silver, the Cisco Capital logo, Cisco IOS, the Cisco IOS logo, *CiscoLink*, the Cisco Powered Network logo, the Cisco Press logo, ClickStart, ControlStream, Fast Step, FragmentFree, IGX, JumpStart, Kernel Proxy, LAN²LAN Enterprise, LAN²LAN Remote Office, MICA, Natural Network Viewer, NetBeyond, Netsys Technologies, *Packet*, PIX, Point and Click Internetworking, Policy Builder, RouteStream, Secure Script, SMARTnet, StrataSphere, StrataSphere BILLder, StrataSphere Connection Manager, StrataSphere Modeler, StrataSphere Optimizer, Stratum, StreamView, SwitchProbe, *The Cell*, TokenSwitch, TrafficDirector, VirtualStream, VlanDirector, Workgroup Director, Workgroup Stack, and XCI are trademarks; The Network Works. No Excuses. is a service mark; and BPX, Catalyst, Cisco, Cisco Systems, the Cisco Systems logo, EtherChannel, FastHub, FastPacket, ForeSight, IPX, LightStream, OptiClass, Phase/IP, StrataCom, and StrataView Plus are registered trademarks of Cisco Systems, Inc. in the U.S. and certain other countries. All other trademarks mentioned in this document are the property of their respective owners.

Copyright © 1997, Cisco Systems, Inc.
All rights reserved. Printed in USA.
9711R