

Cisco VCO/4K ISDN Supplement

January 2004

Corporate Headquarters

Cisco Systems, Inc.
170 West Tasman Drive
San Jose, CA 95134-1706
USA
<http://www.cisco.com>
Tel: 408 526-4000
800 553-NETS (6387)
Fax: 408 526-4100

Text Part Number: OL-5466-01

THE SPECIFICATIONS AND INFORMATION REGARDING THE PRODUCTS IN THIS MANUAL ARE SUBJECT TO CHANGE WITHOUT NOTICE. ALL STATEMENTS, INFORMATION, AND RECOMMENDATIONS IN THIS MANUAL ARE BELIEVED TO BE ACCURATE BUT ARE PRESENTED WITHOUT WARRANTY OF ANY KIND, EXPRESS OR IMPLIED. USERS MUST TAKE FULL RESPONSIBILITY FOR THEIR APPLICATION OF ANY PRODUCTS.

THE SOFTWARE LICENSE AND LIMITED WARRANTY FOR THE ACCOMPANYING PRODUCT ARE SET FORTH IN THE INFORMATION PACKET THAT SHIPPED WITH THE PRODUCT AND ARE INCORPORATED HEREIN BY THIS REFERENCE. IF YOU ARE UNABLE TO LOCATE THE SOFTWARE LICENSE OR LIMITED WARRANTY, CONTACT YOUR CISCO REPRESENTATIVE FOR A COPY.

The Cisco implementation of TCP header compression is an adaptation of a program developed by the University of California, Berkeley (UCB) as part of UCB's public domain version of the UNIX operating system. All rights reserved. Copyright © 1981, Regents of the University of California.

NOTWITHSTANDING ANY OTHER WARRANTY HEREIN, ALL DOCUMENT FILES AND SOFTWARE OF THESE SUPPLIERS ARE PROVIDED "AS IS" WITH ALL FAULTS. CISCO AND THE ABOVE-NAMED SUPPLIERS DISCLAIM ALL WARRANTIES, EXPRESSED OR IMPLIED, INCLUDING, WITHOUT LIMITATION, THOSE OF MERCHANTABILITY, FITNESS FOR A PARTICULAR PURPOSE AND NONINFRINGEMENT OR ARISING FROM A COURSE OF DEALING, USAGE, OR TRADE PRACTICE.

IN NO EVENT SHALL CISCO OR ITS SUPPLIERS BE LIABLE FOR ANY INDIRECT, SPECIAL, CONSEQUENTIAL, OR INCIDENTAL DAMAGES, INCLUDING, WITHOUT LIMITATION, LOST PROFITS OR LOSS OR DAMAGE TO DATA ARISING OUT OF THE USE OR INABILITY TO USE THIS MANUAL, EVEN IF CISCO OR ITS SUPPLIERS HAVE BEEN ADVISED OF THE POSSIBILITY OF SUCH DAMAGES.

CCIP, CCSP, the Cisco Arrow logo, the Cisco *Powered* Network mark, Cisco Unity, Follow Me Browsing, FormShare, and StackWise are trademarks of Cisco Systems, Inc.; Changing the Way We Work, Live, Play, and Learn, and iQuick Study are service marks of Cisco Systems, Inc.; and Aironet, ASIST, BPX, Catalyst, CCDA, CCDP, CCIE, CCNA, CCNP, Cisco, the Cisco Certified Internetwork Expert logo, Cisco IOS, the Cisco IOS logo, Cisco Press, Cisco Systems, Cisco Systems Capital, the Cisco Systems logo, Empowering the Internet Generation, Enterprise/Solver, EtherChannel, EtherSwitch, Fast Step, GigaStack, Internet Quotient, IOS, IP/TV, iQ Expertise, the iQ logo, iQ Net Readiness Scorecard, LightStream, MGX, MICA, the Networkers logo, Networking Academy, Network Registrar, *Packet*, PIX, Post-Routing, Pre-Routing, RateMUX, Registrar, ScriptShare, SlideCast, SMARTnet, StrataView Plus, Stratm, SwitchProbe, TeleRouter, The Fastest Way to Increase Your Internet Quotient, TransPath, and VCO are registered trademarks of Cisco Systems, Inc. and/or its affiliates in the United States and certain other countries.

All other trademarks mentioned in this document or Website are the property of their respective owners. The use of the word partner does not imply a partnership relationship between Cisco and any other company. (0401R)

Cisco VCO/4K ISDN Supplement
Copyright © 2004, Cisco Systems, Inc.
All rights reserved.

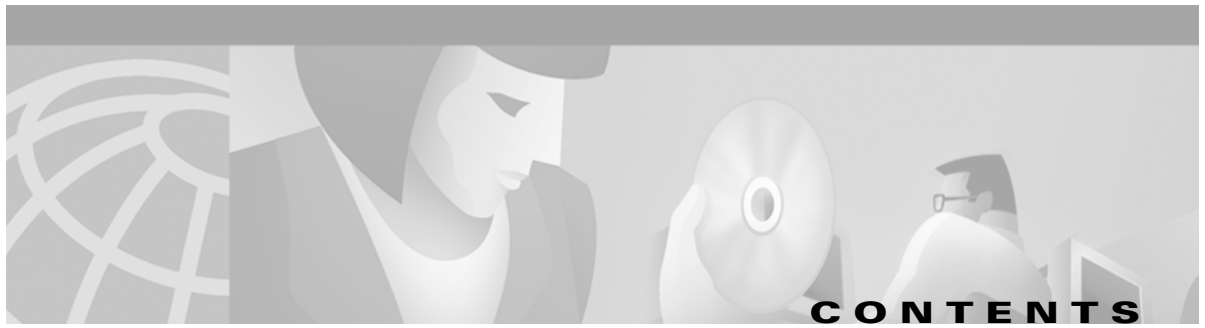

Preface ix

- Objective ix
- Audience ix
- Document Organization ix
- Document Conventions x
- Related Documentation x
- Obtaining Documentation xi
 - Cisco.com xi
 - Ordering Documentation xi
- Documentation Feedback xi
- Obtaining Technical Assistance xii
 - Cisco TAC Website xii
 - Opening a TAC Case xii
 - TAC Case Priority Definitions xii
- Obtaining Additional Publications and Information xiii

CHAPTER 1

Introduction 1-1

- ISDN Primary Rate Interface Package 1-1
 - ISDN PRI Package and ISDN PRI NFAS Package Contents 1-2
- ISDN Non-Facility Associated Signaling (NFAS) Option 1-2
- System Requirements 1-3
 - Hardware Requirements 1-3
 - Software Requirements 1-3
- ISDN PRI and ISDN NFAS Installation 1-3
 - Preinstallation Procedures for Nonredundant VCO Systems 1-4
 - Preinstallation Procedures for Redundant VCO Systems 1-5
 - ISDN PRI and/or ISDN NFAS Installation Instructions for Nonredundant and Redundant VCO Systems 1-6
 - Redundant System Installation and Redundancy Verification 1-9
 - Performing a Database Backup 1-10
 - Software and Hardware Configuration and Installation Instructions 1-11
- ISDN Functional Considerations 1-11
 - Command and Report Processing 1-11
 - Interworking 1-12

- D-Channel Message Handling 1-12
- Primary Rate Interface Synchronization and Timing 1-12
- Primary Rate Interface Diagnostics Mode 1-12
- NFAS Processing 1-12
- ISDN Reference Material 1-13

CHAPTER 2

System Administration Support 2-1

- Card Maintenance Support 2-2
- Interface Controller Card ISDN Span Configuration 2-2
 - ICC ISDN Span Configuration Screen Field Definitions 2-4
 - Field Selections for ICC T1 Span Types 2-10
 - Field Selections for ICC E1 Span Types 2-11
 - Changing ICC ISDN Span Configuration Screen Field Parameters 2-12
 - Accessing Other Menus and Screens 2-14
- System Host Configuration 2-14
 - Configuring the Host Setup Timer 2-14
- System Feature Configuration 2-15
- Inpulse and Outpulse Rule Support 2-16
 - ISDN Associated Impulse and Outpulse Rule Tokens 2-16
 - GLARE [xx] 2-17
 - ISDN RX [xx] 2-17
 - ISDN SUP [xx] 2-17
 - ISDN TX [xx] 2-17
 - NOHOST [xx] 2-18
- ISDN Receive and Transmit Message Templates Summary 2-18
 - ISDN Message Template Summary Screen Field Definitions 2-19
 - Accessing Other Menus and Screens from the ISDN Message Template Summary Screen 2-20
- ISDN Message Templates 2-20
 - ISDN Message Templates Screen Field Definitions 2-21
 - Action Tokens 2-23
 - Adding an ISDN Message Template 2-29
 - Deleting an ISDN Message Template 2-30
 - Adding an Action Token to an ISDN Message Template 2-31
 - Deleting an Action Token from an ISDN Message Template 2-31
 - Accessing Other Menus and Screens from the ISDN Message Templates Screen 2-32
- ISDN Supervision Templates 2-32
 - ISDN Supervision Templates Screen Field Definitions 2-33
 - Condition Tokens 2-34
 - Adding an ISDN Supervision Template 2-36

Deleting an ISDN Supervision Template	2-36
Adding a Condition Token to an ISDN Supervision Template	2-37
Deleting a Condition Token from an ISDN Supervision Template	2-37
Accessing Other Menus and Screens from the ISDN Supervision Template Screen	2-38
Display Card Data	2-38
Port Display	2-39
Port Display Screen Field Definitions—ISDN Specific	2-39
Card Alarm State Messages	2-41

CHAPTER 3**ISDN Processing Overview 3-1**

D-channel Message Processing	3-2
ISDN D-channel Call Clearing Messages	3-4
DISCONNECT	3-4
DISCONNECT Message and Timers T305 and T306	3-5
RELEASE	3-5
RELEASE COMPLETE	3-6
RESTART	3-6
RESTART ACKNOWLEDGE	3-6
ISDN D-channel Call Establishment Messages	3-7
ALERTING	3-7
CALL PROCEEDING	3-7
CONNECT	3-7
CONNECT ACKNOWLEDGE	3-7
PROGRESS	3-7
SETUP	3-7
ISDN D-channel Call Information Phase Message	3-8
User Information	3-8
ISDN D-channel Maintenance Messages	3-8
SERVICE	3-8
SERVICE ACKNOWLEDGE	3-9
ISDN D-channel Miscellaneous Messages	3-9
CONGESTION CONTROL	3-9
FACILITY	3-9
FACILITY ACKNOWLEDGE	3-9
FACILITY REJECT	3-9
NOTIFY	3-9
REGISTER	3-10
STATUS	3-10
STATUS ENQUIRY	3-10

- Information Element Construction 3-10
- ISDN Inpulse Rule Processing 3-11
 - Inpulse Rule Tokens and ISDN Support 3-11
 - ISDN D-channel SETUP Message Processing 3-12
 - ISDN D-channel SETUP Message Processing with a Default Inpulse Rule Defined 3-12
 - ISDN D-channel SETUP Message Processing with No Default Inpulse Rule Defined 3-13
- ISDN Outpulse Rule Processing 3-13
 - Outpulse Rule Tokens and ISDN Support 3-13
 - ISDN Glare Condition Processing 3-14
 - Glare Condition Processing with a Default Inpulse Rule Defined 3-14
 - Glare Condition Processing with No Default Inpulse Rule Defined 3-14
- ISDN PRI Implementation Strategies and Considerations 3-15
 - Use ISDN Message Templates to Specify Information Elements 3-15
 - Use ISDN Message Templates to Process Channel ID Information Elements 3-15
 - Use the REP EACH Token in Inpulse Rules 3-15
 - Specify Call ID Only If No B-channel Has Been Assigned to the Call 3-15

CHAPTER 4

Call Examples 4-1

- Example 1—Response to Incoming SETUP Message 4-5
- Example 2—Selective Reporting of Information Elements and Digit Storage 4-6
- Example 3—Channel ID Processing, Selective IE Storage, and D-Channel Message Construction 4-8
- Example 4—Change of State Reporting Before End of Rule 4-11
- Example 5—Change of State Reporting with End of Rule Reporting Suppressed 4-13
- Example 6—Processing of ISDN Port Control (\$49) Command 4-15
- Example 7—Stable Call Established Via Host Command and Template Processing 4-18
- Example 8—Automatic Call Disconnect 4-22
- Example 9—Manual Call Disconnect 4-25

CHAPTER 5

Non-Facility Associated Signaling (NFAS) 5-1

- NFAS Overview 5-1
 - NFAS Channel Grouping 5-2
 - D-Channel Redundancy 5-2
- NFAS System Administration 5-3
 - NFAS Group Summary Screen 5-3
 - NFAS Group Summary Screen Field Definitions 5-4
 - Changing NFAS Group Summary Screen Field Parameters 5-4
 - Accessing Other Menus and Screens from the NFAS Group Summary Screen 5-5
 - NFAS Configuration Screen 5-5

NFAS Group Configuration Rules	5-6
NFAS Configuration Screen Field Definitions	5-6
Specifying RLS Addresses	5-9
Adding Interfaces to an NFAS Group	5-9
Deleting Interfaces from an NFAS Group	5-10
Changing D-Channel States	5-11
Accessing Other Menus and Screens from the NFAS Configuration Screen	5-11
Additional NFAS System Administration Support	5-11
Card Summary Screen	5-12
Card Maintenance Screen	5-12
ICC ISDN Span Configuration Screen	5-12
ICC Programmable Trunk Configuration Screen	5-13
ICC Programmable Trunk Configuration Screen Field Definitions—NFAS Specific	5-13
NFAS Implementation Strategies and Considerations	5-14
General Sequence for Defining NFAS Resources in the System Database	5-14
Provisioning Primary and Backup D-Channels	5-14
Backup D-channel Configuration	5-14
ICC T1 Channel Usage	5-15
Host Commands During D-Channel Switchover	5-15

APPENDIX A **Valid Information Elements for I FLD and D FLD Action Tokens** A-1

APPENDIX B **Cause Information Elements** B-1

APPENDIX C **D-Channel Backup Processing** C-1

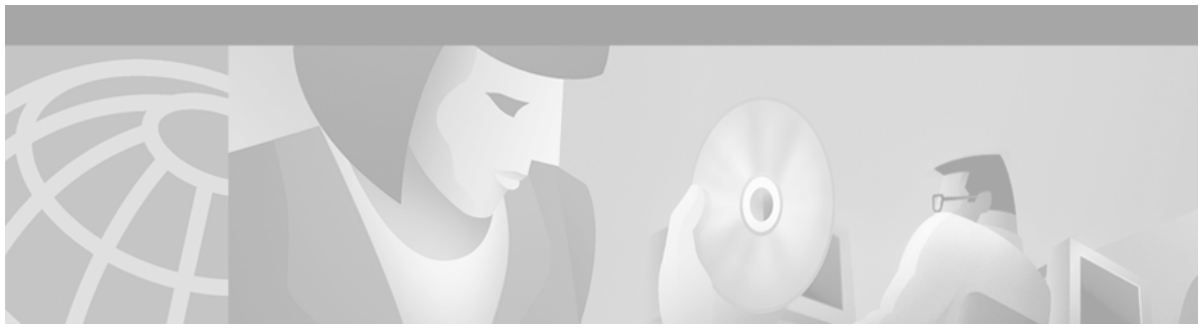

Preface

Objective

The *Cisco VCO/4K ISDN Supplement* provides detailed information on using the Interface Controller Card (ICC) with the Integrated Services Digital Network Primary Rate Interface (ISDN PRI) package and the Non-Facility Associated Signaling (NFAS) option. It emphasizes additional functionality for ISDN PRI and NFAS support.

Use this supplement with the VCO/4K technical documentation set. If a topic is discussed in both the VCO/4K technical documentation set and this supplement, refer to this supplement.

Audience

This guide is intended for all personnel with system administrator privileges and responsible for configuring and maintaining ISDN services. You should be familiar with the components of the switch as well as the system administrator master console. The master console is your access to the system administration functions.

When navigating the system administration menus and screens, you will be directed to use certain command actions such as keyboard entries. These command actions are frequently used throughout this manual. Refer to the *Cisco VCO/4K System Administrator's Guide* for more information.

Certain on-screen commands are available throughout the system administration software. These commands appear in the lower right corner of the screen, and provide visual instruction or direction.

Document Organization

This document is organized as follows:

- Chapter 1, “Introduction,” contains information on your ISDN package contents, the system requirements for using ISDN, and installation instructions.
- Chapter 2, “System Administration Support,” contains detailed information on the system administration utilities.
- Chapter 3, “ISDN Processing Overview,” contains the ISDN processing overview. Readers who are unfamiliar with ISDN protocols may want to begin using this document by reviewing this chapter.

- Chapter 4, “Call Examples,” contains call flow examples. The ISDN processing and call flow example information is appropriate both as a general overview of ISDN support and as detailed application related information.
- Chapter 5, “Non-Facility Associated Signaling (NFAS),” describes the NFAS option, used in North American (T1) applications.
- Appendix A, “Valid Information Elements for I FLD and D FLD Action Tokens,” describes the structure of ISDN information elements (IEs) that are used with I FLD and D FLD action tokens.
- Appendix B, “Cause Information Elements,” lists cause information element (IE) values used by the system.
- Appendix C, “D-Channel Backup Processing,” provides graphic representations of the state transitions occurring on the primary and backup D-channel during channel initialization and switchover.

Document Conventions

This document uses the following conventions:



Note

Means *reader take note*. Notes contain helpful suggestions or references to material not covered in the manual.



Caution

Means *reader be careful*. In this situation, you might do something that could result in equipment damage or loss of data.



Warning

Means *danger*. You are in a situation that could cause bodily injury. Before you work on any equipment, you must be aware of the hazards involved with electrical circuitry and be familiar with standard practices for preventing accidents. To see translated versions of the warning, refer to the *Regulatory Compliance and Safety* document that accompanied the device.

Related Documentation

You may want to refer to the following documents that apply to your Cisco VCO/4K configuration:

- *Cisco VCO/4K System Software Version 5.n(n) Release Notes*
- *Cisco VCO/4K System Administrator's Guide*
- *Cisco VCO/4K System Messages*
- *Cisco VCO/4K Card Technical Descriptions*
- Product supplements for optional software, including:
 - *Cisco VCO/4K Standard Programming Reference*
 - *Cisco VCO/4K Extended Programming Reference*

Obtaining Documentation

Cisco documentation and additional literature are available on Cisco.com. Cisco also provides several ways to obtain technical assistance and other technical resources. These sections explain how to obtain technical information from Cisco Systems.

Cisco.com

You can access the most current Cisco documentation on the World Wide Web at this URL:

<http://www.cisco.com/univercd/home/home.htm>

You can access the Cisco website at this URL:

<http://www.cisco.com>

International Cisco websites can be accessed from this URL:

http://www.cisco.com/public/countries_languages.shtml

Ordering Documentation

You can find instructions for ordering documentation at this URL:

http://www.cisco.com/univercd/cc/td/doc/es_inpck/pdi.htm

You can order Cisco documentation in these ways:

- Registered Cisco.com users (Cisco direct customers) can order Cisco product documentation from the Ordering tool:
<http://www.cisco.com/en/US/partner/ordering/index.shtml>
- Nonregistered Cisco.com users can order documentation through a local account representative by calling Cisco Systems Corporate Headquarters (California, USA) at 408 526-7208 or, elsewhere in North America, by calling 800 553-NETS (6387).

Documentation Feedback

You can submit e-mail comments about technical documentation to bug-doc@cisco.com.

You can submit comments by using the response card (if present) behind the front cover of your document or by writing to the following address:

Cisco Systems
Attn: Customer Document Ordering
170 West Tasman Drive
San Jose, CA 95134-9883

We appreciate your comments.

Obtaining Technical Assistance

For all customers, partners, resellers, and distributors who hold valid Cisco service contracts, the Cisco Technical Assistance Center (TAC) provides 24-hour-a-day, award-winning technical support services, online and over the phone. Cisco.com features the Cisco TAC website as an online starting point for technical assistance. If you do not hold a valid Cisco service contract, please contact your reseller.

Cisco TAC Website

The Cisco TAC website provides online documents and tools for troubleshooting and resolving technical issues with Cisco products and technologies. The Cisco TAC website is available 24 hours a day, 365 days a year. The Cisco TAC website is located at this URL:

<http://www.cisco.com/tac>

Accessing all the tools on the Cisco TAC website requires a Cisco.com user ID and password. If you have a valid service contract but do not have a login ID or password, register at this URL:

<http://tools.cisco.com/RPF/register/register.do>

Opening a TAC Case

Using the online TAC Case Open Tool is the fastest way to open P3 and P4 cases. (P3 and P4 cases are those in which your network is minimally impaired or for which you require product information.) After you describe your situation, the TAC Case Open Tool automatically recommends resources for an immediate solution. If your issue is not resolved using the recommended resources, your case will be assigned to a Cisco TAC engineer. The online TAC Case Open Tool is located at this URL:

<http://www.cisco.com/tac/caseopen>

For P1 or P2 cases (P1 and P2 cases are those in which your production network is down or severely degraded) or if you do not have Internet access, contact Cisco TAC by telephone. Cisco TAC engineers are assigned immediately to P1 and P2 cases to help keep your business operations running smoothly.

To open a case by telephone, use one of the following numbers:

Asia-Pacific: +61 2 8446 7411 (Australia: 1 800 805 227)

EMEA: +32 2 704 55 55

USA: 1 800 553-2447

For a complete listing of Cisco TAC contacts, go to this URL:

<http://www.cisco.com/warp/public/687/Directory/DirTAC.shtml>

TAC Case Priority Definitions

To ensure that all cases are reported in a standard format, Cisco has established case priority definitions.

Priority 1 (P1)—Your network is “down” or there is a critical impact to your business operations. You and Cisco will commit all necessary resources around the clock to resolve the situation.

Priority 2 (P2)—Operation of an existing network is severely degraded, or significant aspects of your business operation are negatively affected by inadequate performance of Cisco products. You and Cisco will commit full-time resources during normal business hours to resolve the situation.

Priority 3 (P3)—Operational performance of your network is impaired, but most business operations remain functional. You and Cisco will commit resources during normal business hours to restore service to satisfactory levels.

Priority 4 (P4)—You require information or assistance with Cisco product capabilities, installation, or configuration. There is little or no effect on your business operations.

Obtaining Additional Publications and Information

Information about Cisco products, technologies, and network solutions is available from various online and printed sources.

- Cisco Marketplace provides a variety of Cisco books, reference guides, and logo merchandise. Go to this URL to visit the company store:
<http://www.cisco.com/go/marketplace/>
- The *Cisco Product Catalog* describes the networking products offered by Cisco Systems, as well as ordering and customer support services. Access the Cisco Product Catalog at this URL:
<http://cisco.com/univercd/cc/td/doc/pcat/>
- *Cisco Press* publishes a wide range of general networking, training and certification titles. Both new and experienced users will benefit from these publications. For current Cisco Press titles and other information, go to Cisco Press online at this URL:
<http://www.ciscopress.com>
- *Packet* magazine is the Cisco quarterly publication that provides the latest networking trends, technology breakthroughs, and Cisco products and solutions to help industry professionals get the most from their networking investment. Included are networking deployment and troubleshooting tips, configuration examples, customer case studies, tutorials and training, certification information, and links to numerous in-depth online resources. You can access Packet magazine at this URL:
<http://www.cisco.com/packet>
- *iQ Magazine* is the Cisco bimonthly publication that delivers the latest information about Internet business strategies for executives. You can access iQ Magazine at this URL:
<http://www.cisco.com/go/iqmagazine>
- *Internet Protocol Journal* is a quarterly journal published by Cisco Systems for engineering professionals involved in designing, developing, and operating public and private internets and intranets. You can access the Internet Protocol Journal at this URL:
<http://www.cisco.com/ipj>
- Training—Cisco offers world-class networking training. Current offerings in network training are listed at this URL:
<http://www.cisco.com/en/US/learning/index.html>



Introduction

ISDN Primary Rate Interface Package

The ISDN PRI package provides call processing and administrative support for ISDN PRI services. ITU Q.921/931 access to T1 ISDN switch types (4ESS, 5ESS, NI-2, NTI, NTT) and E1 ISDN switch types (EURO, QSIG, TS014) can be configured for each Interface Controller Card (ICC) Primary Rate Interface (PRI) ISDN span in the system.

ICC cards are available in three configurations supporting four, eight, or sixteen PRI ISDN spans, depending upon the I/O module with which they are used.

Four, eight, and sixteen span I/O modules each consist of four groups of spans. Each span is defined as an RLS—rack, level, slot—address. The format of the RLS address is x x x-x-x, where the first x represents the rack, the second x represents the level, and the last three represent the slot. A four span I/O module, referred to as a 4x I/O module, has one span in each of the four groups, an 8x I/O module has two spans in each group, and a 16x I/O module has four spans in each group. Table 1-1 is a representation of what the RLS addresses of 4x, 8x, and 16x ICC PRI ISDN I/O module spans would be, if the ICC card and I/O module are located in slot 15 of a VCO system chassis.

Table 1-1 Rack, Level, and Slot Addresses of 4x, 8x, and 16x I/O Module Spans

I/O Module	RLS Addresses			
	Group 1	Group 2	Group 3	Group 4
4 span	1 1 15-1-1	1 1 15-2-1	1 1 15-3-1	1 1 15-4-1
8 span	1 1 15-1-1	1 1 15-2-1	1 1 15-3-1	1 1 15-4-1
	1 1 15-1-2	1 1 15-2-2	1 1 15-3-2	1 1 15-4-2
16 span	1 1 15-1-1	1 1 15-2-1	1 1 15-3-1	1 1 15-4-1
	1 1 15-1-2	1 1 15-2-2	1 1 15-3-2	1 1 15-4-2
	1 1 15-1-3	1 1 15-2-3	1 1 15-3-3	1 1 15-4-3
	1 1 15-1-4	1 1 15-2-4	1 1 15-3-4	1 1 15-4-4

Each T1 ICC PRI ISDN span provides 23 bearer channels (B-channels) and a single data channel (D-channel) for transmission of ISDN control messages (23 B+D). For T1 ISDN switch types, users may select D3/D4 format, or extended super frame (ESF) format on a per span basis, with bipolar 8-zeros signaling (B8ZS) bit encoding. The D-channel is not inverted.

Each E1 ICC PRI ISDN span provides 30 B-channels and a single D-channel for transmission of ISDN control messages (30 B+D). For E1 ISDN switch types, users may select CRC4 format, or non-CRC4 format on a per span basis, with high-density bipolar 3-zeros signaling (HDB3) bit encoding. The D-channel is not inverted.

ICC PRI ISDN span operation supports the Physical, Data Link, and Network Layers (1, 2, and 3) of the Open Systems Interconnection (OSI) model to provide interface with ISDN D-channel protocols. The ICC application software, stored on the system hard disk, is downloaded to the ICC PRI ISDN span by the generic software only when a new version is available; otherwise, the application is stored in flash memory on the ICC card. This application on the ICC interacts with the call processing functions running on the system controller.

Full system administration support is provided to allow ICC PRI ISDN span configuration, alarm detection and processing, and span maintenance functions. Enhancements to system call processing allow ISDN features and capabilities to be added to an application with no effect on existing applications. Use the ISDN message templates and rule processing to enhance programmable reporting of ISDN events and facilitate construction of outgoing D-channel messages. Use the ISDN supervision templates to control outgoing ISDN calls. These features support not only pure ISDN calls, but also calls which use a mixture of ISDN and non-ISDN resources. These mixed resource cases, called interworking scenarios, allow the system to act as a gateway between the ISDN and traditional services networks.

Every attempt has been made to provide full ISDN PRI support for T1 switch types (4ESS, 5ESS, NI-2, NTI, NTT) and E1 switch types (EURO, QSIG, TS014). Contact the Cisco Systems TAC if your application encounters any compatibility problems.

ISDN PRI Package and ISDN PRI NFAS Package Contents

The ISDN PRI package consists of the following components:

- *Cisco VCO/4K ISDN Supplement*
- ISDN PRI V5.1 FSR00 PUN24, or higher software on a 3.5-inch diskette
- Optional software diskettes

The ISDN PRI NFAS package consists of the following components:

- *Cisco VCO/4K ISDN Supplement*
- ISDN PRI V5.1 FSR00 PUN24, or higher software on a 3.5-inch diskette
- ISDN NFAS V5.1 FSR00 PUN24, or higher software on a 3.5-inch diskette
- Optional software diskettes

Verify the contents of the package. If any of the components listed above are missing, contact the Cisco Systems TAC.

ISDN Non-Facility Associated Signaling (NFAS) Option

The ISDN NFAS option supports AT&T 4ESS, AT&T 5ESS, NI-2, and NTI (DMS-100/250) switches and allows a single D-channel to control up to 20 interfaces.

Assign the ICC PRI ISDN spans to NFAS groups through the system administration screens. Each NFAS group consists of an interface containing the primary D-channel and up to 19 additional interfaces—ICC T1 spans configured for clear channel signaling. You can configure up to 37 NFAS groups, each with a separate primary D-channel. An optional backup D-channel can also be configured for each group.

The NFAS option details are contained in Chapter 5, “Non-Facility Associated Signaling (NFAS).”

System Requirements

This section provides system requirements for running the ISDN PRI package. These requirements are categorized by hardware and software. Contact the Cisco Systems Customer Response Center for any site-specific concerns.

Hardware Requirements

The ISDN PRI package Version 5.1 or higher requires a VCO/4K system equipped with ICC card(s) and their corresponding I/O modules. Refer to the “Software and Hardware Configuration and Installation Instructions” section on page 1-11 for hardware configuration requirements and installation instructions.

Software Requirements

The ISDN PRI package Version 5.1 or higher requires system software V5.1 FSR00 PUN24, or higher. Refer to the “Software and Hardware Configuration and Installation Instructions” section on page 1-11 for software configuration requirements and instructions.

ISDN PRI and ISDN NFAS Installation

This section details the procedure for installing ISDN PRI and ISDN NFAS. You should have a working knowledge of system operation, and the VCO system should be running system V5.1 FSR00 PUN24, or higher.

**Note**

If you are not installing either, or both, the ISDN PRI and the NFAS diskettes as part of a system software installation or upgrade, follow the installation instructions below; otherwise, refer to the *Cisco VCO/4K System Software Release Notes* for installation instructions.

The software needed to run ISDN PRI on your system is included as part of the system software. However, you need the two Optional Software diskettes, which contain an installation utility, to enable ISDN PRI on your system. This utility consists of an installation program and a set of DOS-like disk utilities that perform operations such as database backup during the installation. Read and understand all the material contained in this section before proceeding with the installation.

The system must be off line before you can perform the installation procedure. Estimated time for the completion of the software installation is 10 minutes (20 minutes for a redundant system).

Use the following tools during your installation:

- One wrist strap, worn during installation procedures and when handling system components
- One 3.5-inch diskette for the database backup procedure, described in the “Performing a Database Backup” section on page 1-10

In addition, you must use a local console session to accomplish the installation. For VCO/4K and VCO/20 systems, connect a dumb terminal, a PC with dumb terminal emulation, or a terminal server to the Port 1/Console port which is located on the back end of the Storage/Control I/O module. For VCO/80 systems, connect a dumb terminal, a PC with dumb terminal emulation, or a terminal server to the Serial Port 1 Console port on the CPU-TM module.

Refer to the following manuals during installation:

- *Cisco VCO/4K Software Installation Guide*
- *Cisco VCO/4K Maintenance Manual*
- *Cisco VCO/4K System Administrator's Guide*

The ISDN NFAS option is enabled by installing both the ISDN PRI diskette and the ISDN NFAS diskette. Now you can perform the preinstallation procedures for your nonredundant, or redundant, VCO system. Refer to the following sections for your system's configuration.

Preinstallation Procedures for Nonredundant VCO Systems

Ensure that your nonredundant system meets the following configuration guidelines before you can successfully install the ISDN PRI and/or ISDN NFAS software applications.



Note

The system must be fully powered up.

- Step 1** Position the Select toggle switch on the Alarm Arbiter Card (AAC) to the A setting. Verify that the A Active LED is lit (green) and the B Active LED is not lit.
- Step 2** Log in to the active (ACT) side of the system, and ensure that the Redundant System feature flag, found in the System Features screen, is set to N; if not, set the feature flag to N to disable this feature.
- Step 3** Set the local console to 9600 kbps, if it is not set already. The local console must be set to 9600 kbps for you to see all CPU reboot messages during the installation. To set the console:
- Log in to the system and access the System Configuration Menu screen.
 - Select **A**, Peripheral Configuration, and set the local TTY baud rate to 9600.
 - Change the console to 9600 kbps.



Note

Perform this procedure on both the A-side and the B-side.

You have completed the preinstallation procedures for nonredundant systems. Now you can install the ISDN PRI and/or ISDN NFAS diskettes on your VCO system. Refer to the “ISDN PRI and/or ISDN NFAS Installation Instructions for Nonredundant and Redundant VCO Systems” section on page 1-6 for installation instructions.

Preinstallation Procedures for Redundant VCO Systems

Ensure that your redundant system meets the following configuration guidelines before you can successfully install the ISDN PRI and/or ISDN NFAS software applications.



Note The system must be fully powered up.

- Step 1** Position the Select toggle switch on the Alarm Arbiter Card (AAC) to the AUTO setting.
- Step 2** Log in to the active (ACT) side of the system, and ensure that the Redundant System feature flag, found in the System Features screen, is set to Y; if not, set the feature flag to Y to enable this feature.
- Step 3** Set the local console to 9600 kbps, if it is not set already. The local console must be set to 9600 kbps for you to see all CPU reboot messages during the installation.



Note Perform this on both the A-side and the B-side.

To set the console:

- a. Log in to the system and access the System Configuration Menu screen.
 - b. Select **A**, Peripheral Configuration, and set the local TTY baud rate to 9600.
 - c. Change the console to 9600 kbps.
- Step 4** Make the A-side active. If the state of the system is A-SBY/B-ACT, log in to the B-side and execute the Switch ACT System to SBY command (selection E) of the Maintenance Menu screen. Otherwise, proceed to the Step 5.



Note The state of the system is displayed at the bottom of the console screen.

- Step 5** Position the Select toggle switch on the AAC to the A setting.
- Step 6** Verify that the system console indicates the A-ACT/B-SBY state, which can take up to 60 seconds for the system to update.
- Step 7** Verify that the A Active LED is lit (green) and the B Active LED is not lit, on the AAC.
- Step 8** Verify that there are no alarms marked as fatal or critical by accessing the System Alarms Display screen and inspecting the log file.



Note All fatal and critical alarms must be resolved before attempting this software installation. In addition, any alarm (fatal, critical, major, or minor) which contains the phrase Update Channel or the term UPD, must be resolved.

- Step 9** Verify a received “FRMxxx ALM080: Update Channel Failure” alarm message in the log file. The B-side must be taken off line before the software installation can begin. This action generates an “FRMxxxALM080: Update Channel Failure” alarm message. This message is verified in one of two ways, depending upon which system you are using:
- For a VCO/4K or VCO/20 system, verify that the “FRMxxx ALM080: Update Channel Failure” alarm message was received by unseating the B-side Combined Controller Card, logging in to the A-side, and verifying that the message was received.



Note Leave the Combined Controller unseated until instructed otherwise.

- For a VCO/80 system, verify that the “FRMxxx ALM080: Update Channel Failure” alarm message was received by pressing the B-side VME power module off, logging in to the A-side, and verifying that the message was received.



Note Leave the B-side VME power module powered off until instructed otherwise.

The “FRMxxx ALM080: Update Channel Failure” alarm message clears after the installation is completed on the B-side.

Step 10 Log out of the A-side.

You have completed the preinstallation procedures for redundant systems. Now you can install the ISDN PRI and/or ISDN NFAS diskettes on your VCO system.

ISDN PRI and/or ISDN NFAS Installation Instructions for Nonredundant and Redundant VCO Systems

Complete the following steps to install the ISDN PRI package and/or ISDN NFAS package on your VCO system:

- Step 1** Insert the ISDN PRI diskette into the A-side floppy disk drive.
- Step 2** Press the A RESET push button on the AAC. The A-side boots from the boot code present on the ISDN PRI diskette. The system controller (CPU) outputs a series of boot messages, and then the Installation Utilities screen appears (see Figure 1-1).
- Step 3** Perform a database backup. Refer to the “Performing a Database Backup” section on page 1-10 for database backup instructions.
- Step 4** Type **1** and press **Return**, in the Installation Utilities screen. The following message appears:

```
Do You Wish To Back-Up The System Data Base? (Y/N) _
```

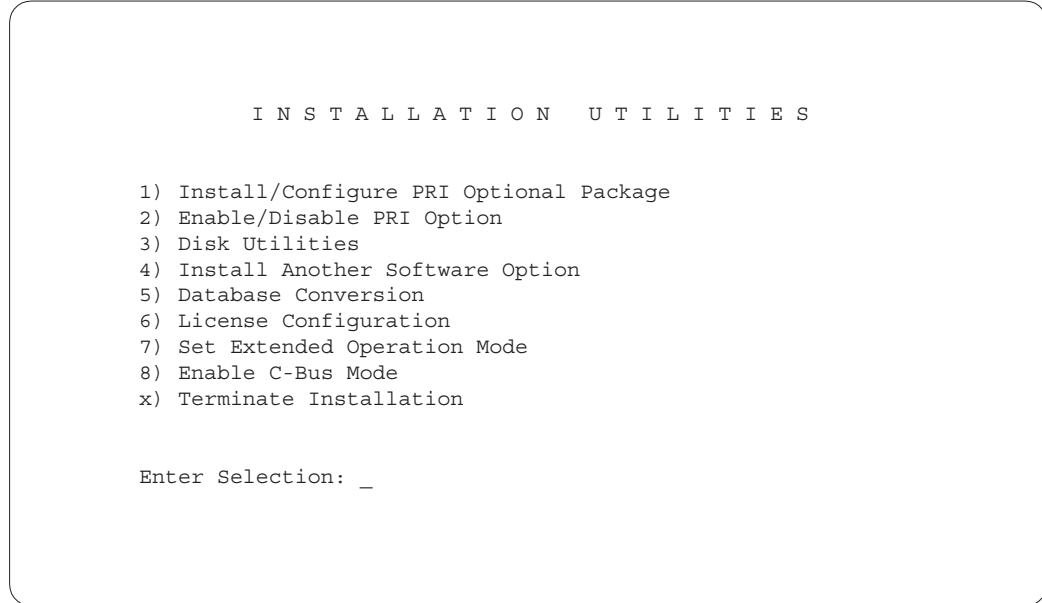
Figure 1-1 ISDN Primary Rate Interface Installation Utilities Screen

50648

Step 5 Type **N** and press **Return**. The following messages are displayed:

```

Copying A:/BOOT/PRI.DWN...
1 file[s] copied
Copying A:/BOOT/PRIN.DWN...
1 file[s] copied
ISDN-PRI Option Enabled

```

The Installation Utilities screen appears (see Figure 1-1).

Step 6 Type **4** and press **Return**, if you are installing the ISDN NFAS package; otherwise, proceed to Step 11 to terminate the installation procedure. The following messages are displayed:

```

Install Another Install Disk
Press Return to Continue

```

Step 7 Insert the ISDN NFAS diskette and press **Return**. The Installation Utilities screen is displayed (see Figure 1-2).

Step 8 Type **1** and press **Return**. The screen clears and the following message is displayed:

```

Do You Wish To Back-Up The System Data Base? (Y/N) _

```

Figure 1-2 Non-Facility Associated Signaling Installation Utilities Screen

```

                                I N S T A L L A T I O N   U T I L I T I E S

1) Install/Configure NFAS Optional Package
2) Enable/Disable NFAS Option
3) Disk Utilities
4) Install Another Software Option
5) Database Conversion
6) License Configuration
7) Set Extended Operation Mode
8) Enable C-Bus Mode
x) Terminate Installation

Enter Selection: __

```

50649

Step 9 Type **N** and press **Return**. The following messages are displayed, and then the Installation Utilities screen display appears (see Figure 1-2):

```

Copying A:/BOOT/NFAS.EXE...
1 file[s] copied
Copying A:/BOOT/PRIN.DWN...
1 file[s] copied
Copying A:/BOOT/PRI.DWN...
1 file[s] copied
NFAS Option Enabled

```

Step 10 Remove the diskette.

Step 11 Type **x** and press **Return** to terminate the installation. The following message is displayed:

```

Terminate Installation Utility? (Y/N) _

```

Step 12 Type **Y** and press **Return**. The following messages are displayed:

```

Remove Installation Diskette NOW!
Suspending Installation Process...
Rebooting.....
Reset System NOW!

```



Note You may see the “Reset System NOW!” message. If you see the message, press the A RESET push button on the AAC. If you do not see the message, do not press the RESET button—the system reboots automatically in this case.

Step 13 Proceed to Step 14 if you are installing the software on the A-side of a redundant system.

Proceed to “Software and Hardware Configuration and Installation Instructions” section on page 1-11 if you are installing the software on the A-side of a nonredundant system, or if you are installing the software on the B-side of a redundant system. Your installation is complete; do not proceed further in these instructions.

Step 14 Move the console to the B-side.



Note When installing the software on the B-side, you must leave the Select toggle switch on the Alarm Arbiter Card (AAC) at the A setting.

Step 15 Insert the ISDN PRI diskette in the B-side floppy disk drive.

Step 16 Configure your system's hardware. Your configuration procedure is dependent upon which system you are using.

- For VCO/4K and VCO/20 systems, insert the B-side Combined Controller card. The card reboots automatically from the code present on the ISDN PRI diskette.
- For VCO/80 systems, press on the B-side VME power module. The B-side reboots automatically from the code present on the ISDN PRI diskette.

The Installation Utilities screen is displayed. Proceed to step 4 of these instructions and complete the installation.

You have completed the ISDN PRI and ISDN NFAS installation procedures for your system. The system finishes rebooting and the login screen is displayed.

Redundant System Installation and Redundancy Verification

For redundant systems, verify that file synchronization has occurred. Perform the following steps:

- Step 1** Access the log file and verify that the RED32:ACT FILE SYNC COMPLETED message is present from the active side.
- Step 2** Access the log file and verify that the RED20:ACT FILE SYNC COMPLETED message is present from the standby side.
- Step 3** Access the System Alarms Display screen and verify that there are no alarms containing the phrase Update Channel, or the term UPD.
- Step 4** Position the Select toggle switch on the AAC card to the AUTO setting.

Now you can configure the software and install the hardware for the ICC PRI ISDN spans. Refer to "Software and Hardware Configuration and Installation Instructions" section on page 1-11 for further information and instructions.

Performing a Database Backup

To perform a database backup with the Disk Utilities screen, complete the following steps.



Note

Before making the backup, prepare a DOS-formatted 3.5-inch high-density diskette on which you have created a DBASE directory. You can create the directory with the standard DOS utility MKDIR.

- Step 1** Access the Installation Utilities screen.
- Step 2** Insert a formatted high-density diskette into the floppy drive.
- Step 3** Type **3** and press **Return**. The Disk Utilities Menu screen is displayed (see Figure 1-3).

Figure 1-3 Disk Utilities Menu Screen

```

          D I S K   U T I L I T I E S   M E N U

A) Show Directory           M) Compress File
B) Copy Files              N) Uncompress File
C) Delete Files           O) Split File
D) Rename Files           P) Join Files
E) Database Store         Q) Tone Files Installation/Removal
F) Database Retrieve
G) Display File
H) Show Free Space On Disk
I) Format Disk
J) Create Directory
K) Delete Directory
L) Rename Directory

Enter Selection: _

```

48369

- Step 4** Type **2** and press **Return**. The following message appears:
Enter file to be copied:
- Step 5** Type **c:/dbase/*.tbl** and press **Return**. The following message appears:
Enter target file:
- Step 6** Type **a:/dbase** and press **Return**. The following message appears:
Copying files...

When all files are copied, the Disk Utilities Menu screen is displayed (see Figure 1-3).

- Step 7** Verify that the database was backed up onto the floppy disk as follows:
 - a. Type **1**.
 - b. Type **a:/dbase** and press **Return**.

Step 8 Type **15** and press **Return** to exit the Disk Utilities Menu screen and return to the Installation Utilities screen.

Step 9 Remove the backup diskette.



Note For redundant systems, you do not need to back up the database on the B-side. Backing up the database on the A-side is sufficient.

The database backup procedure is now complete. Continue with the installation procedures described in the preceding sections.

Software and Hardware Configuration and Installation Instructions

The software and hardware associated with the ICC PRI ISDN package must be configured and installed according to the following steps:

- Step 1** Log in to the system and add the ICC PRI ISDN span(s) to the system database. Refer to the *Cisco VCO/4K System Administrator's Guide* for instructions.
- Step 2** Configure the ICC PRI ISDN span(s) in the database. Refer to Chapter 2, "System Administration Support," for instructions.
- Step 3** Insert the ICC I/O module into the appropriate slot at the rear of the VCO system chassis.
- Step 4** Insert the ICC card into the corresponding slot at the front of the VCO system chassis.

You must perform two further configuration issues to enable ISDN call processing on your system.

- Additional database entry for inpulse and outpulse rules, ISDN message templates, and ISDN supervision templates is required. Refer to the other chapters in this document for information.
- All ICC PRI ISDN spans must be brought into service—status changed to active—using the Card Maintenance screen. Refer to the *Cisco VCO/4K System Administrator's Guide* for instructions.

Contact the Cisco Systems TAC if you encounter any difficulties during the installation process.

ISDN Functional Considerations

Cisco Systems has identified and evaluated functional considerations in the ISDN PRI and ISDN NFAS software packages. This section provides explanations and, where applicable, workarounds for functional considerations in the areas that follow. These considerations are in addition to the known functional constraints, which are contained in the *Cisco VCO/4K System Software Release Notes*.

Command and Report Processing

The use of the Null Output Rule in the ISDN Port Control (\$49) command (null outpulse rule 0) is not supported for ISDN channels.

Interworking

For interworking scenarios in which the incoming port is an ISDN B-channel and the outgoing is another type of interface, the condition token ANSBK (answerback) cannot be used in conjunction with the TIME event to satisfy the supervision template. In this case, the incoming B-channel remains in CP_WANS state when the event occurs. The call does not go stable; no information is transferred to the SBY controller (if the system is equipped with redundant system controllers).

D-Channel Message Handling

The following functional considerations have been identified in D-channel message handling:

- **PROGRESS Messages with Invalid Information Element Content**—When the system receives an ISDN D-channel call establishment PROGRESS message with invalid IE content, it clears the call. In this case, the system should ignore the message according to standard ISDN call models. Processing of correct PROGRESS messages works properly.
- **180 Byte Length Limit**—The VCO system limits the length of transmitted D-channel messages to 180 bytes. Messages which exceed this length are truncated.

Primary Rate Interface Synchronization and Timing

The following functional considerations have been identified in PRI synchronization and timing:

- **SLIP Conditions in Channel Service Unit (CSU) Connections**—SLIPs can occur if the ICC PRI ISDN span is connected to a CSU and the current timing source is Internal or Incoming.
- **PRI Synchronization Loss Problem**—It is possible to lose synchronization without the detection of carrier loss or an out of frame (OOF) condition. When synchronization is lost, the appropriate log file messages are generated to provide the address of the ICC PRI ISDN span.
- **ICC PRI ISDN Span as Incoming Timing Source**—Following system power up or reset, ICC PRI ISDN spans that do not have a functional D-channel cannot be used as the primary incoming timing source (the system uses the secondary source or reverts to its internal clock). This condition only occurs immediately following power up or reset. During system operation, if an ICC PRI ISDN span is designated as the incoming master timing source, the system syncs to the incoming stream regardless of the state of the D-channel on the span.

Primary Rate Interface Diagnostics Mode

All PRI diagnostic mode utilities are performed via the Card Maintenance screen, and performed to the ICC card. Refer to the *Cisco VCO/4K System Administrator's Guide* for further information.

NFAS Processing

Switch Types Supporting NFAS Operation—The four Switch Type settings on the ICC ISDN Span Configuration screen which are supported in NFAS are

- ICC-T1 PRI/4ESS
- ICC-T1 PRI/5ESS

- ICC-T1 PRI/NI-2
- ICC-T1 PRI/NTI

All other switch types (ICC-T1 PRI/NTT, ICC-E1 PRI/NET5 (EURO), ICC-E1 PRI/QSIG, and ICC-E1 PRI/TS014) are not supported with NFAS operations. Verify that all ICC PRI ISDN spans placed in NFAS groups are configured for appropriate connections.

ISDN Reference Material

This document describes and defines the ISDN configuration implemented for your system. For general ISDN information and details on ISDN message and information element structure, refer to the International Telecommunications Union's document *ITU-T Q.931*. Implementation of ISDN protocols on the ICC was based on information contained in the following documents.

Refer to the following documents for further information on the National ISDN-2 (NI-2) protocol:

- Bellcore. *1996 Version of National ISDN Primary Rate Interface Customer Premises Equipment Generic Guidelines*; Piscataway, New Jersey, SR-3338.
- Bellcore. *1999 Version of National ISDN Primary Rate Interface (PRI) Customer Premises Equipment Generic Guidelines (SR-4619)*.

Refer to the following documents for further information on the AT&T #4 Electronic Switching System, and AT&T #5 Electronic Switching System (4ESS and 5ESS) protocols:

- AT&T Bell Laboratories. *AT&T Integrated Services Digital Network (ISDN) Primary Rate Interface Specification*. Holmdel, New Jersey: AT&T Bell Laboratories, July 1989. *Technical Reference 41449*, Issue 2.0.
- AT&T Bell Laboratories. *AT&T Network Integrated Services Digital Network (ISDN) Primary Rate Interface and Special Application Specification; User-Network Interface Description*. Holmdel, New Jersey: AT&T Bell Laboratories, August 1996. *Technical Reference 41459*.
- AT&T Bell Laboratories. *5ESS Switch ISDN Primary Rate Interface Specification 5E6 Software Release; AT&T 235-900-322*. AT&T Document Development Organization, September 1990.

Refer to the following document for further information on the Northern Telecom, Inc., (NTI) protocol:

- Northern Telecom. *ISDN Primary Rate User-Network Interface Specification*. Research Triangle Park, North Carolina: Northern Telecom, Inc., December 1989. *NIS A211-1* Version 2.

Refer to the following document for further information on the Nippon Telegraph and Telephone Corporation (NTT) protocol:

- Nippon Telegraph and Telephone Corporation. *INS-Net Interface and Services*. March 1993.

Refer to the following documents for further information on the European Telecommunications Standard network-userside-interface, EURO, protocol:

- European Telecommunications Standard. *Integrated Services Digital Network (ISDN)*. France: European Telecommunications Standards Institute, September, 1992. *ETS 300 156*.
- European Telecommunications Standard. *Integrated Services Digital Network (ISDN)*. France: European Telecommunications Standards Institute, August, 1990. *ETS 300 102-1*.
- European Telecommunications Standard. *Integrated Services Digital Network (ISDN)*. France: European Telecommunications Standards Institute, December, 1990. *ETS 300 102-2*.
- European Telecommunications Standard. *Integrated Services Digital Network (ISDN)*. France: European Telecommunications Standards Institute, September, 1991. *ETS 300 125*.

Refer to the following documents for further information on the Private Integrated Signaling System No. 1 (PSS1) Q-reference Point Signaling (QSIG) protocol:

- Private Integrated Services Network (PISN). *Circuit Mode Bearer Services – Inter-Exchange Signaling Procedures and Protocol: ECMA – 143*; third edition; June 1997.
- *European Telecommunications Standard – ETS 300 172*; third edition; November 1995.
- *European Telecommunications Standard – ETS 300 172*; second edition; January 1994.
- *European Telecommunications Standard – ETS 300 172*; December 1992.

Refer to the following document for further information on the Australia Communications Authority (ACA) Technical Standard 014 (TS 014) protocol:

- Australia Communications Authority. *General Requirements for Customer Equipment Connected to an ISDN Primary Rate Interface. ACA TS 014 - 1997*; third edition.



System Administration Support

The configuration of the Interface Controller Card (ICC) Primary Rate Interface (PRI) ISDN span is accomplished with most system administration utilities. Use the Card Maintenance screen to add ICC ISDN spans to the system database and place them in service (IS) and out of service (OOS). Place all PRI B-channels into resource groups the same way you would other system network interface ports.



Note

PRI D-channels cannot be added to a resource group.

System administration utilities specific to ISDN PRI support include the ICC ISDN Span Configuration screen, ISDN Message Template Summary screen, ISDN Message Template screen, and the ISDN Supervision Templates screen.

This chapter highlights system administration support for the ISDN PRI package, concentrating on the following areas:

- Adding ICC ISDN spans into the system database
 - Card Maintenance screen
 - ICC ISDN Span Configuration screen
 - Specific ICC ISDN Span Configuration screen ICC ISDN T1 and E1 field selections
- Configuring the Host Setup Timer
- Configuring ISDN feature flags
- Defining ICC ISDN span processing on the system
 - Inpulse and outpulse rule support
 - ISDN Message Template Summary screen
 - ISDN Message Templates screen
 - ISDN Supervision Templates screen
- Performing diagnostics and maintenance
 - Card Display screen
 - Port Display screen
 - Card and system alarms and their associated messages

Chapter 5, “Non-Facility Associated Signaling (NFAS),” describes the additional system administration functions provided to support ISDN Non-Facility Associated Signaling (NFAS). Use the information in Chapter 5 in conjunction with the *Cisco VCO/4K System Administrator's Guide*.

Card Maintenance Support

ICC ISDN spans are fully supported by the system administration Card Maintenance screen. Refer to the *Cisco VCO/4K System Administrator's Guide* for detailed information on this screen. Additional information specific to ICC ISDN span support is provided in this section.

When you add an ICC T1 ISDN span to the database via the Card Maintenance screen, the system controller assigns the first available contiguous block of 24 port addresses to the span. The first 23 port addresses are assigned to the B-channels, and the twenty-fourth address is reserved for the D-channel.

When you add an ICC E1 ISDN span to the database via the Card Maintenance screen, the system controller assigns the first available contiguous block of 32 port addresses to the span as follows:

- Port 1 is the synchronization channel and cannot be assigned to a port group.
- Port 17 is reserved for the D-channel and cannot be assigned to a port group.
- Ports 2 through 16 and ports 18 through 32 are assigned to the B-channels.

The initial status of the span (either T1 or E1) is OOS. Use the **C** command (change status) to place the span in active mode. When the card comes into service, it transitions to the maintenance mode. The span remains in maintenance mode until the ICC ISDN application is downloaded, all signal alarms are cleared, and the D-channel link is established.

The span status mode reflects the state of the ICC ISDN span D-channel. All span status modes are supported for the ICC ISDN span except for the standby mode and the camped on mode. Diagnostic mode places the span into local loopback. An additional diagnostic mode, remote (**R**), has been added so you can place the span into remote loopback.

Use the card maintenance **P** command to deactivate/activate each B-channel on the span. Deactivating a B-channel places the port into a near-end OOS state. ISDN states can be viewed with the system administration Port Display screen.

When a span is manually placed into maintenance mode, the idle B-channels are placed into maintenance near-end state. Active calls are not affected. The associated B-channels of released calls are placed into the near-end maintenance mode.

The system supports autonomous channel maintenance processing through the use of the SERVICE and SERVICE ACKNOWLEDGE D-channel messages. In user mode (applicable to ICC-T1 PRI/4ESS, ICC-T1 PRI/5ESS, ICC-T1 PRI/NI-2, ICC-T1 PRI/NTI, ICC-T1 PRI/NTT, ICC-E1 PRI/NET5 (EURO), and ICC -E1 PRI/TS014 spans), when the D-channel is running and all signal alarms have cleared, B-channels assume the far-end OOS state until the network brings them into active service. In user-symmetrical mode (applicable to ICC-T1 PRI/4ESS, ICC-T1 PRI/5ESS, ICC-T1 PRI/NI-2, and ICC-T1 PRI/NTI), B-channels are automatically brought into active service.

Interface Controller Card ISDN Span Configuration

Use the ICC ISDN Span Configuration screen to define the operating characteristics of an ICC ISDN span, and to assign port names to the B-channels associated with that span. Refer to the *Cisco VCO/4K System Administrator's Guide* for more information.

To access the ICC ISDN Span Configuration screen from the Card Summary screen, follow these steps:

-
- Step 1** Use the **Prev Field** or **Next Field** key to position the cursor in the DISP CARD field corresponding to the ICC ISDN span for which you want to display configuration information.

Step 2 Type any character and press **Enter**.



Note

The status field of the ICC ISDN Span Configuration screen must indicate that the ICC ISDN span is in the OOS state before you can configure its operating characteristics.

There are two different ICC ISDN Span Configuration screens—only one of which will be displayed on your monitor. One screen is associated with ICC T1 spans, the other is associated with ICC E1 spans.

The ICC ISDN Span Configuration screen associated with ICC T1 spans is shown in Figure 2-1. T1 ISDN types include 4ESS, ESS, NI-2, NTI, and NTT.

Figure 2-1 ICC ISDN Span Configuration Screen for ICC T1 Spans

```

      I C C  I S D N  S P A N  C O N F I G U R A T I O N

SPAN LOCATION: R,L,S 1 1 15-1-1      TYPE  : ICC-T1 PRI/NI2
                                      STATUS: Out of Service

ACCESS TYPE: USER      TRX CLOCK: SCLK  CA IP RULE: 0  SLIP MAINT LIMIT: 255
SWITCH TYPE: NI2       REF CLOCK: LOOP  NCA IP RULE: 0  OOF MAINT LIMIT: 17
SPAN LENGTH: 0-133    SPAN TYPE:  ESF   A/Mu LAW:   Mu

      PORT      NAME      GROUP      GRP NAME      COS
      ---      -
      1          -          -          -             2
      2          -          -          -             2
      3          -          -          -             2
      4          -          -          -             2
      5          -          -          -             2
      6          -          -          -             2
      7          -          -          -             2
      8          -          -          -             2
  
```

50588

The ICC ISDN Span Configuration screen associated with ICC E1 spans is shown in Figure 2-2. The E1 ISDN types include NET5 (EURO), QSIG, and TS014.



Note

Figure 2-2 represents the screen for E1 ISDN types EURO and QSIG; E1 ISDN type TS014 is represented by the same screen, but excludes the OVERLAP field. The per-span overlap feature is not available for TS014 span types.

Figure 2-2 ICC ISDN Span Configuration Screen for ICC E1 Spans

```

      I C C I S D N S P A N C O N F I G U R A T I O N

SPAN LOCATION: R,L,S 1 1 15-1-1      TYPE  : ICC-E1 PRI/NET5
                                      STATUS: Out of Service

ACCESS TYPE: USER      TRX CLOCK: SCLK  CA IP RULE: 3  SLIP MAINT LIMIT: 255
SWITCH TYPE: NET5_UK  REF CLOCK: LOOP  NCA IP RULE: 0  OOF MAINT LIMIT: 17
SPAN LENGTH: 533-655  CRC4      : ON    A/Mu LAW:  A  OVERLAP: FORWARD

      PORT      NAME      GROUP      GRP NAME      COS
      ----      -
      1          -          -          -          2
      2          -          -          -          2
      3          -          -          -          2
      4          -          -          -          2
      5          -          -          -          2
      6          -          -          -          2
      7          -          -          -          2
      8          -          -          -          2

```

50588

The ICC ISDN Span Configuration screen for T1 types can consist of up to three screens, each containing information on a maximum of eight ports. Ports corresponding to the 23 B-channels are displayed in ascending order.

The ICC ISDN Span Configuration screen for E1 types can consist of up to four screens, each containing a maximum of eight ports. Ports corresponding to the 30 B-channels are displayed in ascending order.

**Note**

For T1 types, port 24 (the D-channel), and information for deactivated ports (taken out of service via the **P** command), are not displayed. For E1 types, port 17 (the D-channel), and information for deactivated ports taken OOS, are not displayed.

Press **Prev Field** and **Next Field** to move between fields. Press **Tab** and **<** to move between the first field on each line. Press **Prev Screen** and **Next Screen** to page through the listings. Press **Print Screen** to obtain a hard copy of any of the screens.

ICC ISDN Span Configuration Screen Field Definitions

The ICC ISDN Span Configuration screen contains the following fields:

SPAN LOCATION—*Display only*. The rack-level-slot address of the span. Refer to the “ISDN Primary Rate Interface Package” section on page 1-1 for span location conventions.

TYPE—*Display only*. Indicates the type of span in that location. The valid values for ISDN PRI are either ICC-T1 PRI/x or ICC-E1 PRI/x, where x represents a particular ISDN protocol. (See Chapter 5, “Non-Facility Associated Signaling (NFAS),” for ISDN NFAS values.)

STATUS—*Display only*. Indicates the current status of the span. To change span status, use the Card Maintenance screen. The field also reflects the status of the span due to signal alarms and establishment or release of the D-channel. Possible values for this field are listed in Table 2-1.

Table 2-1 STATUS Field Values and Meanings

Value	Meaning
Active	D-channel is established and all signal alarms are clear. B-channels (ports) on this span can be involved in active calls and can be allocated to new calls.
Out of Service (OOS)	D-channel is disabled. No B-channels (ports) on this span can be involved in active calls; no ports are allocated to new calls.
Maintenance	D-channel may be disabled and an alarm condition may exist. If you placed the span into maintenance through the Card Maintenance screen, the D-channel is still active. One or more B-channels (ports) on this span may be involved in active calls; no ports are allocated to new calls. The span enters this state automatically upon system reset, when the D-channel releases, or for a signal alarm. When the condition clears, the span transitions back to the active state.
Diagnostics	D-channel is disabled. No B-channels (ports) on this span are involved in calls or allocated to new calls. The span is in local loopback and sending all ones (1s).
Remote	D-channel is not disabled. No B-channels (ports) on this span are involved in calls or allocated to new calls. Span is in local and remote loopback.

ACCESS TYPE—The ACCESS TYPE selections vary according to span type. The ACCESS TYPE field selections for T1 spans are described in the “Field Selections for ICC T1 Span Types” section on page 2-10. The ACCESS TYPE field selections for E1 spans are described in the “Field Selections for ICC E1 Span Types” section on page 2-11.

TRX CLOCK—*Data entry via Select or Rev Select key.* Specifies the transmit clock (timing source) used for this span. Possible values for this field are listed in Table 2-2. You can only change this field when the span status is OOS.

Table 2-2 TRX CLOCK Field Values and Meanings

Value	Meaning
SCLK	Transmit PRI stream timing derived from system master timing link—as set via system administration or host T1 Synchronization Control (\$C0 02) command; default value.
LOOP	Transmit PRI stream timing derived from the received stream.
1544 (for T1 spans)	Transmit T1 PRI stream timing synchronized to the crystal clock on the ICC.
2048 (for E1 spans)	Transmit E1 PRI stream timing synchronized to the crystal clock on the ICC.

TRX CLOCK specifies which clock source is used for the transmission of data. If you set the TRX CLOCK to LOOP, the clock recovered from the received data is used to clock the data from the transmit buffer. In this case, transmit and receive slips are correlated.

If you set the TRX CLOCK to SCLK, the system clock is used to clock the data (effectively bypassing the transmit buffer). If there is any disparity between the remote system’s clock and the system’s clock, the slips are effectively exported to the remote system.

LOOP is recommended for plesiochronous networks.

1544, for T1 spans, and 2048, for E1 spans, are not recommended for normal operation; they are generally used for testing purposes.

**Note**

If selecting the ICC board crystal clock (1544 or 2048), you must make this selection for all spans in that group. For example, if you select the TRX CLOCK value of 1544 for one span in a group, you must select 1544 for all other spans in that group. Again, 1544 and 2048 are not recommended for normal operation.

Refer to Table 1-1 for a description of groups and their RLS addresses.

CA IP RULE—*Data entry via main keyboard.* Specifies the default impulse rule for call-associated connections. (Call-associated connections deliver services over the B-channel.) This rule applies when the channel ID information element within the SETUP message specifies a B-channel as the bearer channel. The impulse rule you choose must have already been defined in the Impulse Rule Table screens. Possible values for this field are 0 (no default impulse rule) or a number between 1 and 255. Default value is 0.

SLIP MAINT LIMIT—*Data entry via main keyboard.* Specifies the number of transmit or receive slips that can be detected for this span in a 24-hour period before threshold processing occurs. Threshold processing either resets the span or puts it in maintenance mode for manual intervention.

This processing is controlled when you set the manual intervention for SLIP/OOF feature flag in the System Features Configuration screen. Refer to the *Cisco VCO/4K System Administrator's Guide* for more information.

Separate slip maintenance counts are maintained for receive and transmit slips. When either of these counters reaches the limit, threshold processing occurs. The current slip count is displayed on the Card Display screen. Slip counters are reset at midnight or when you change this value in the ICC ISDN Span Configuration screen. Possible values for this field are between 0 (slip maintenance processing is inhibited—recommended when the TRX Clock setting is LOOP) and 255. Default value is 255.

SWITCH TYPE—The SWITCH TYPE selections vary according to span type. The SWITCH TYPE field selections for T1 spans are described in the “Field Selections for ICC T1 Span Types” section on page 2-10. The SWITCH TYPE field selections for E1 spans are described in the “Field Selections for ICC E1 Span Types” section on page 2-11.

REF CLOCK—*Data entry via Select or Rev Select key.* Determines the reference clock (timing source) used for this span. This rule applies only if this span has been specified as the current timing source using either the Master Timing Link Selection menu or the T1 Synchronization Control (\$C0 02) command. Possible values for this field are listed in Table 2-3. You can only change this field when the span status is OOS.

Table 2-3 REF CLOCK Field Values and Meanings

Value	Meaning
LOOP	Reference clock is derived from LIU (Line Interface Unit); default value.
1544 (for T1 spans)	Reference clock is derived from the crystal clock on the ICC.
2048 (for E1 spans)	Reference clock is derived from the crystal clock on the ICC.

NCA IP RULE—*Data entry via main keyboard.* Specifies the default impulse rule for non-call associated connections. This rule applies when the channel ID within the SETUP message specifies the D-channel as the bearer channel. The impulse rule you choose must have already been defined in the Impulse Rule Table screens. Possible values for this field are between 1 and 255. Default value is 0.

OOF MAINT LIMIT—*Data entry via main keyboard.* Specifies the number of out of frames (OOFs) that can be detected for this span in a 24-hour period before threshold processing occurs. Threshold processing either resets the span or puts it in maintenance mode for manual intervention. This processing is controlled by the setting of the manual intervention for SLIP/OOF feature flag on the System Features Configuration screen. Refer to the *Cisco VCO/4K System Administrator's Guide* for more information.

The OOF counter is reset at midnight and when this value is changed. Possible values for this field are between 0 (OOF maintenance processing inhibited—not recommended) and 255; default value is 17.

SPAN LENGTH—*Data entry via Select or Rev Select key.* Determines the line equalization used for the data stream. Choices are expressed either in terms of the cable length between the ICC ISDN span and the connected equipment or as defined by FCC Part 68 Option A. Possible values for this field are listed in Table 2-4. You can only change this field when the span status is OOS.

Table 2-4 SPAN LENGTH Field Values and Meanings

Value	Meaning
0 to 133	Line length between 0 and 133 feet (0 to 40.5 meters)
133 to 266	Line length between 133 and 266 feet (40.5 to 81 meters)
266 to 399	Line length between 266 and 399 feet (81 to 121.6 meters)
399 to 533	Line length between 399 and 533 feet (121.6 to 162.4 meters)
533 to 655	Line length between 533 and 655 feet (162.4 to 199.6 meters)
PT 68 A	Equalization as defined by FCC Part 68 Option A

SPAN TYPE—*Data entry via Select or Rev Select key.* This field is valid for T1 spans only; refer to Figure 2-1. Specifies the format of the data stream. This value can only be changed when the span status is OOS. Possible values for this field are listed in Table 2-5.

Table 2-5 SPAN TYPE Field Values and Meanings

Value	Meaning
ESF	Extended Superframe format, B8ZS (bipolar 8-zeroes signaling); default value
D3/D4	T1 D3/D4 format, B8ZS (bipolar 8-zeroes signaling)

CRC4—*Data entry via Select or Rev Select key.* This field is valid for E1 spans only; refer to Figure 2-2. Cyclic Redundancy Check 4 (CRC4), is an enhanced error monitoring capability providing additional protection against simulation of the frame alignment signal. This value can only be changed when the span status is OOS. Possible values for this field and their meanings are listed in Table 2-6.

Table 2-6 CRC4 Field Values and Meanings

Value	Meaning
ON	Cyclic Redundancy Check 4 on
OFF	Cyclic Redundancy Check 4 off



A/Mu LAW—*Data entry via Select or Rev Select key.* Specifies voice coding on the PRI stream. The system automatically turns off translation for calls which specify unrestricted digital information bearer capability. Possible values for this field are listed in Table 2-7.

Table 2-7 A/Mu LAW Field Values and Meanings

Value	Meaning
Mu	Mu Law encoding (T1 ISDN spans)
A	A Law encoding (E1 ISDN spans)
SYS	System backplane law; this law is selected to match the entry in the Set System to A-Law field of the System Features screen. This is especially useful to spans carrying signaling data which cannot undergo law conversion.

OVERLAP—*Data entry via Select or Rev Select key.* Specifies per-span overlap configuration. This field is used for NET5 (EURO) and QSIG E1 span types; all other span types, both E1 and T1, are not supported. Possible values for this field are listed in Table 2-8.

Table 2-8 OVERLAP Field Values and Meanings

Value	Meaning
FORWARD	<p>Select this value if the host is responsible for handling the sending/receiving of overlap messages on this span.</p> <p>The initial SETUP message and any subsequent INFO messages are sent by the VCO/4K, as they are received, to the host. The host is responsible for sending the SETUP ACKNOWLEDGE message.</p> <p> Note This value contains the same meaning as selecting Y in the now defunct Enable NET5 Overlap Receiving feature flag.</p>
ACCUMULATE	<p>Select this value if the host is not capable of handling the sending/receiving of overlap messages on this span.</p> <p>The initial SETUP message is held by the VCO/4K, while the VCO/4K generates the SETUP ACKNOWLEDGE message and accumulates any subsequent INFO messages before sending one SETUP message to the host which contains all the data from the initial SETUP message and the INFO messages.</p> <p> Note This value contains the same meaning as selecting N in the now defunct Enable NET5 Overlap Receiving feature flag.</p>

**Note**

The next five fields—PORT, NAME, GROUP, GRP NAME, and COS—contain information pertaining to the individual ports on the ICC ISDN span. However, for ICC-T1 ISDN types, port 24 (the D-channel), and deactivated ports (taken out of service via the **P** command) are not displayed. For ICC-E1 ISDN types, port 17 (the D-channel), and deactivated ports are not displayed.

PORT—*Display only*. Indicates the port number on the span. There are 23 ports, or B-channels on T1 type ICC ISDN spans, and 30 B-channels on E1 type ICC ISDN spans.

NAME—*Data entry via main keyboard*. Optional database entry used to identify individual B-channels. When a port name is used, each one should be unique and descriptive of port usage. This field accepts up to eight alphanumeric characters, either upper- and/or lowercase.

GROUP—*Display only*. Indicates the number of the resource group to which this port belongs. If no resource group assignment has been made, this field is blank. This field can be changed using the Resource Group Configuration screens. Possible values for this field range between 1 and 255.

GRP NAME—*Display only*. Indicates the name of the resource group to which this port belongs. If no resource group assignment has been made, this field is blank. This field can be changed using the Resource Group Summary screen, and can contain up to eight alphanumeric characters, either upper- and/or lowercase.

COS—*Data entry via main keyboard*. Class of service; for ISDN B-channels, used for resource grouping and B-channel allocation processing. Spans can have different COS marks, as determined by the application design. Assignable values for this field are listed in Table 2-9.

**Note**

Internal COS values such as U2 (2-way currently used as an outgoing) and T2 (2-way currently used as an incoming) may appear in this field during system operation. These values are internal processing representations and are not assignable by the user.

Table 2-9 COS Field Values and Meanings

Value	Meaning
O	Originating—Calls originating from the system; outgoing calls initiated by host command.
T	Terminating—Calls terminating at the system; incoming calls initiated by actions outside the system or forced by host command.
2	2-Way—Calls originating from the VCO or calls terminating at the system; outgoing calls initiated by host command, incoming calls initiated by outside actions.
AO	Always Off Hook and Originating—Calls originating from the system, port goes off hook at system reset and remains off hook; outgoing calls initiated by host command.
AT	Always Off Hook and Terminating—Calls terminating at the system, port goes off hook at VCO system reset and remains off hook; incoming calls initiated by outside actions or forced by host command.
A2	Always Off Hook and 2-Way—Calls originating from the system or calls terminating at the system, port goes off hook at system reset and remains off hook; outgoing calls initiated by host command, incoming calls initiated by outside actions or forced by host command.

Field Selections for ICC T1 Span Types

The ICC ISDN Span Configuration screen ACCESS TYPE and SWITCH TYPE field selections vary according to ICC T1 span type. Five ICC ISDN T1 span types are supported. They include 4ESS, 5ESS, NI-2, NTI, and NTT. The ACCESS TYPE and SWITCH TYPE field selections for each ICC ISDN T1 type are described below. Refer to Figure 2-1 for the location of these fields within the screen.

ACCESS TYPE—*Data entry via Select or Rev Select key.* Specifies the type of access connection used for this span. You can only change this field when the span status is OOS. Refer to Table 2-10 for the different selection options available for the ICC T1 span types.

Table 2-10 ACCESS TYPE Field Selections for ICC T1 Span Types

Span Type	Selection Option	Selection Meaning
ICC-T1 PRI/4ESS	USER	User side implementation for the connection
	USER-SYM	User side symmetrical implementation for the connection (loop-back only)
ICC-T1 PRI/5ESS	USER	User side implementation for the connection
	USER-SYM	User side symmetrical implementation for the connection (loop-back only)
ICC-T1 PRI/NI-2	USER	User side implementation for the connection
	USER-SYM	User side symmetrical implementation for the connection (loop-back only)
ICC-T1 PRI/NTI	USER	User side implementation for the connection
	USER-SYM	User side symmetrical implementation for the connection (loop-back only)
ICC-T1 PRI/NTT	USER	User side implementation for the connection
	NETWORK	Network side implementation for the connection

SWITCH TYPE—For NTT spans—*Data entry via Select and Rev Select keys.* All other T1 span types are not selectable. Determines the type of switch to which this PRI ISDN span is to be connected. This allows for the correct handling of manufacturer-specific ISDN implementations. The span status must be OOS in order to change this field.

Possible values for this field are listed in Table 2-11.

Table 2-11 SWITCH TYPE Field Selections for ICC T1 Span Types

Span Type	Selection Option	Selection Meaning
ICC-T1 PRI/4ESS	4ESS	AT&T 4ESS
ICC-T1 PRI/5ESS	5ESS	AT&T 5ESS
ICC-T1 PRI/NI-2	NI-2	National ISDN-2
	NI2_SERV ¹	National ISDN-2 with SERVICE message support.
ICC-T1 PRI/NTI	NTI	Northern Telecom DMS-100/250
ICC-T1 PRI/NTT	NTT	Japanese (NTT) ISDN
	NTT_CS	Continuous Set Asynchronous Balance Mode (SABME) version of Japanese (NTT) ISDN

1. The NI2_SERV switch type parameter allows the control of B-channel initialization, and supports SERVICE and SERVICE ACKNOWLEDGEMENT messages. The following restrictions apply:

- Transmission of RESTART message is not supported.
- Connection to a Cisco router ISDN interface is not supported.
- Supports only the USER side—ACCESS TYPE field configured as USER.
- The VCO/4K end expects the network to bring the B-channels into service.
- Used only when the far end (network side) supports B-channel availability control procedures contained in the Bellcore standard, SR-4619.

Refer to the *1999 Version of National ISDN Primary Rate Interface (PRI) Customer Premises Equipment Generic Guidelines (SR-4619)* for further information on B-channel availability control procedures.

Field Selections for ICC E1 Span Types

The ICC ISDN Span Configuration screen ACCESS TYPE and SWITCH TYPE field selections vary according to ICC E1 span type. Three ICC ISDN E1 span types are supported. They include NET5 (EURO), QSIG, and TS014. The ACCESS TYPE and SWITCH TYPE field selections for each ICC ISDN E1 type are described below. Refer to Figure 2-2 for the location of this field within the screen.

ACCESS TYPE— *Data entry via Select or Rev Select key.* Specifies the type of access connection used for this span. You can only change this field when the span status is OOS. Refer to Table 2-12 for the different selection options available for the ICC E1 span types.

Table 2-12 ACCESS TYPE Field Selections for ICC E1 Span Types

Span Type	Selection Option	Selection Meaning
ICC-E1 PRI/NET5	USER	User side implementation for the connection
	NETWORK	Network side implementation for the connection
ICC-E1 PRI/TS014	USER	User side implementation for the connection
	NETWORK	Network side implementation for the connection
ICC-E1 PRI/QSIG	USER-A	One side of symmetrical inter-PINX link for the connection ¹
	USER-B	One side of symmetrical inter-PINX link for the connection ¹

1. PINX = Private Integrated Services Network Exchange.

SWITCH TYPE—*Data entry via Select and Rev Select keys.* Determines the type of switch to which this PRI ISDN span is to be connected. This allows for the correct handling of manufacturer-specific ISDN implementations. The span status must be OOS in order to change this field.

Possible values for this field are listed in Table 2-13.

Table 2-13 SWITCH TYPE Field Selections for ICC E1 Span Types

Span Type	Selection Option	Selection Meaning
ICC-E1 PRI/NET5	NET5_AUS	Austria variant
	NET5_BEL	Belgium variant
	NET5_DEN	Denmark variant
	NET5_FIN	Finland variant
	NET5_FRA	France variant
	NET5_GER	Germany variant
	NET5_GRC	Greece variant
	NET5_ICE	Iceland variant
	NET5_IRE	Ireland variant
	NET5_NED	Netherlands variant
	NET5_NOR	Norway variant
	NET5_POR	Portugal variant
	NET5_SPA	Spain variant
	NET5_SWE	Sweden variant
	NET5_SWI	Switzerland variant
	NET5_UK	United Kingdom variant
NET5_LUX	Luxembourg variant	
NET5_ITA	Italian variant	
ICC-E1 PRI/QSIG	QSIG	European private network signaling protocol
ICC-E1 PRI/TS014	TS014	Australian ISDN

Changing ICC ISDN Span Configuration Screen Field Parameters

Use the ICC ISDN Span Configuration screen to change the ACCESS TYPE, TRX CLOCK, CA IP RULE, SLIP MAINT LIMIT, SWITCH TYPE, REF CLOCK, NCA IP RULE, OOF MAINT LIMIT, SPAN LENGTH, SPAN TYPE, CRC4, A/Mu LAW, NAME, and COS fields.



Note

Take the span out of service through the Card Maintenance screen before changing the ACCESS TYPE, TRX CLOCK, SWITCH TYPE, REF CLOCK, SPAN LENGTH, SPAN TYPE, CRC4, or A/Mu LAW fields. Refer to the *Cisco VCO/4K System Administrator's Guide* for instructions to take your span out of service.

To change the ICC ISDN span parameters, complete the following steps:

-
- Step 1** Display the ICC ISDN Span Configuration screen for the span you want to change (refer to the “Interface Controller Card ISDN Span Configuration” section on page 2-2).
 - Step 2** Press **Next Field**. The cursor moves to the ACCESS TYPE field.
 - Step 3** Use the **Select** and **Rev Select** keys to step through the values until the correct access type is shown, then press **Next Field**. The cursor moves to the TRX CLOCK field.
 - Step 4** Use the **Select** and **Rev Select** keys to step through the values until the correct TRX clock value is shown, then press **Next Field**. The cursor moves to the CA IP RULE field.
 - Step 5** Type the impulse rule number for call associated connections, if any, then press **Next Field**. The cursor moves to the SLIP MAINT LIMIT field. If no impulse rule number is entered, the field display changes to 0.
 - Step 6** The SLIP MAINT LIMIT field contains a default value of 255. To change it, type the new value, then press **Next Field**. The cursor moves to the SWITCH TYPE field.
 - Step 7** Use the **Select** and **Rev Select** keys to step through the values until the correct switch type is shown, then press **Next Field**. The cursor moves to the REF CLOCK field.
 - Step 8** Use the **Select** and **Rev Select** keys to step through the values until the correct reference clock value is shown, then press **Next Field**. The cursor moves to the NCA IP RULE field.
 - Step 9** Type the impulse rule number for non-call associated connections, then press **Next Field**. The cursor moves to the A/Mu LAW field. If you do not enter an impulse rule number, the field display changes to 0.
 - Step 10** Use the **Select** and **Rev Select** keys to step through the values until the correct A/Mu Law encoding value is shown, then press **Next Field**. The cursor moves to the OOF MAINT LIMIT field.
 - Step 11** The OOF MAINT LIMIT field contains a default value of 17. To change it, type the new value, then press **Next Field**. The cursor moves to the SPAN LENGTH field.
 - Step 12** Use the **Select** and **Rev Select** keys to step through the values until the correct span length value is shown, then press **Next Field**. The cursor moves to the SPAN TYPE field.
 - Step 13** Use the **Select** and **Rev Select** keys to step through the values until the correct span type value is shown, then press **Next Field**. The cursor moves to the NAME field for the first port on the span.
 - Step 14** Type the name information, if any, and then press **Next Field**. The cursor skips over the GROUP and GRP NAME fields and moves to the **COS** field for that port.
 - Step 15** Type the Class of Service character(s). Press **Next Field**. The cursor moves to the NAME field for the next port.
 - Step 16** Repeat Steps 13 and 14 until all changes for the eight ports displayed have been made, then press **Next Screen** to display ports 9 to 16.
Make any changes necessary, then press **Next Screen** to display ports 17 to 23 and make any changes necessary.
Use **Prev Screen** and **Next Screen** to move among the screens until all changes have been made.
 - Step 17** Press **Enter**; the system database is automatically updated.
 - Step 18** Press **Exit** to return to the Card Summary screen.

To leave the ICC ISDN Span Configuration screen without making any changes, press **Exit**, **Prev Menu**, or **Main Menu**. No changes are made to the database unless you press **Enter**.

Accessing Other Menus and Screens

You can access the following screens from the ICC ISDN Span Configuration screen:

- Main menu—Press the **Main Menu** key.
- Database Administration menu—Press the **Prev Menu** key.
- Card Summary screen—Press the **Exit** key.

System Host Configuration

The system software contains one System Host Configuration screen field that has an affect on ISDN processing—the Host Setup Timer field. The Host Setup Timer uses a timer which you configure (from 1 to 60 seconds) to trap the condition in which a host link fails to respond to a call attempt, a D-channel SETUP message.

The System Host Configuration screen is shown in Figure 2-3.

Figure 2-3 System Host Configuration Screen

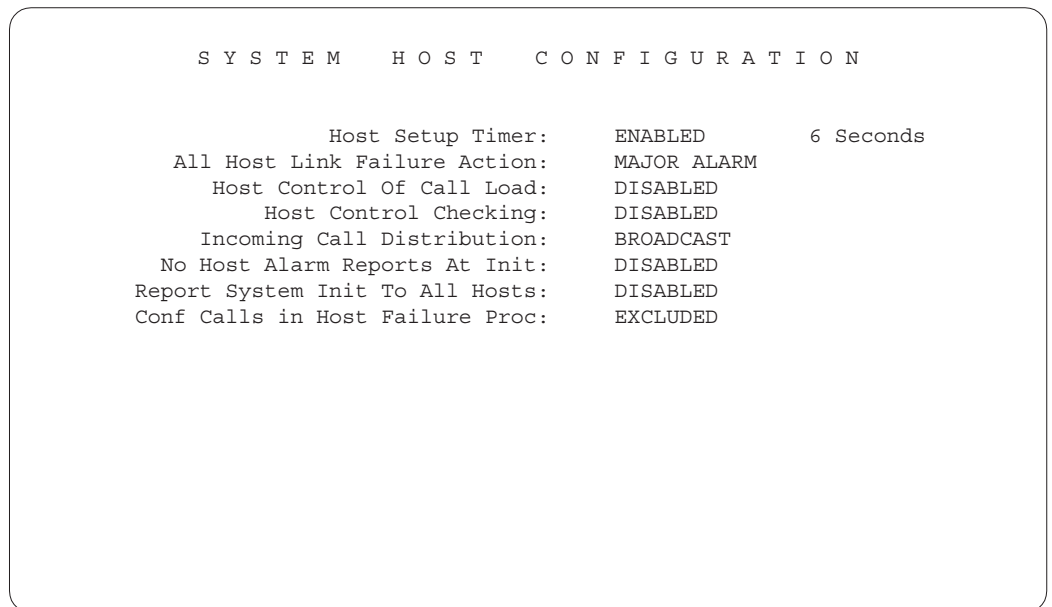

Configure the Host Setup Timer field to enable or disable host setup timing, as well as to configure the duration of the timer. In addition to this ISDN-specific field, there are the standard System Host Configuration screen fields, which are described in the *Cisco VCO/4K System Administrator's Guide*.

Configuring the Host Setup Timer

To enable/disable the Host Setup Timer, press the **Select** and **Rev Select** keys. When it is enabled, the default time of 6 seconds is displayed in the next field. When it is disabled, this field is blank.

To modify the default time, enable the Host Setup Timer and use the keypad to enter the new time.

The Host Setup Timer, if enabled, is performed for the assigned host link. If the assigned host process does not respond to the initial call report, D-channel SETUP message, within the defined Host Setup Timer interval, the call is torn down. A line/trunk port marked as an Always Off-hook class of service is set back to idle state. Line/trunk ports with other classes of service are processed through permanent signaling conditioning (PSC).

The Host Setup Timer processing provides the reorder sequence when no host link is available to control the call.

You can modify the behavior of the Host Setup Timer with one of the following methods:

- Specify the NOHOST inpulse rule token to enable the system to execute the inpulse rule indicated in the token's additional data field (rule numbers 1 to 255).

If the host times out, the NOHOST inpulse rule token forces rule processing to execute the inpulse rule specified in the data field of the NOHOST inpulse rule token. This behavior can cause delays in tearing down a call which is not responded to by a host. Note that a self-referential NOHOST token can cause the inpulse rule to loop indefinitely.

Refer to the "Inpulse and Outpulse Rule Support" section on page 2-16 for more information.

- Specify an inpulse rule for a port to enable the Host Setup Timer to start upon rule completion, in which case the call may not be torn down immediately.
- Disable the Host Setup Timer to enable the system to wait indefinitely for the host to respond.

Refer to the *Cisco VCO/4K System Administrator's Guide* for more information on the System Host Configuration screen and inpulse rules.

System Feature Configuration

The VCO/4K system software contains the following System Features screen fields that have an affect on ISDN processing:

- Enable ISDN Manual Disconnect
- Send all ISDN Connect Reports
- Cut Thru For Non-ISDN Alerting
- \$EA Reports on DChannel RESTART
- Send All ISDN Disconnect Report
- Enable Host Call Ref

Refer to the *Cisco VCO/4K System Administrator's Guide* for a description of these features, and for feature setting instructions. The System Features screen is shown in Figure 2-4.

Figure 2-4 System Features Screen

S Y S T E M F E A T U R E S			
FEATURES	ALLOWED (Y,N)	FEATURES	ALLOWED (Y,N)
Redundant System	N	Send All ISDN Connect Reports	N
Output Periodic Alarm Reports	N	Enable \$66 Cmd Host Checking	N
Card/Alarm Status at Init.	N	Cut Thru For Non-ISDN Alerting	N
Manual Intervention For SLIP/OOF	N	Enable 4th Column DTMF	N
Enable Grace Timing On Null Rule	N	Set System to A-Law	Y
Disable Card Error Report/Reset	N	Enable AllPortsDeactivated Alrm	N
Enable Digit Field Reporting	N	\$EA Reports on DChannel RESTART	N
Suppress PSC/Rule Abort Messages	N	Send All ISDN Disconnect Report	N
Enable Host Password Check	N	Convert Reorder Tone To Busy	N
Force Bearer/Lap Activation	N	K1197 Layer 3 Testing	N
Enable MFC-R2 Supervised Clear	N	Enable Host Call Ref	N
Enable SLIC Guarded Disconnect	N	Extended Operation Mode Set	N
Enable CPA Monitor Disconnect	N	C-bus Mode Enabled	N
Revert to Basic Redundancy	N		
Send Reports Before Guard Time	N		
Enable ISDN Manual Disconnect	N		

48345

Inpulse and Outpulse Rule Support

The ISDN PRI package is fully supported by inpulse and outpulse rule processing. This support is defined by the following rule processing abilities:

- ISDN RX [xx] inpulse and outpulse rule tokens, used to call ISDN message templates.
- ISDN TX [xx] inpulse and outpulse rule tokens, used to call ISDN message templates.
- ISDN SUP [xx] outpulse rule token, used to call ISDN supervision templates.
- GLARE [xx] inpulse rule token, used to execute a specified inpulse rule when a glare condition occurs.
- NOHOST [xx] inpulse rule token, used to execute a specified inpulse rule following the expiration of the Host Setup Timer.

ISDN Associated Impulse and Outpulse Rule Tokens

The tokens used to support ISDN call processing are unique instructions that, when combined with other tokens, compose inpulse and outpulse rules. Each token takes advantage of a function within the system, and the ISDN supporting tokens are limited to two types—supervision control and processing control functions.

Supervision control consists of in-band or out-of-band signaling to the distant end (i.e., answer, wink, tone, voice prompt) or waits a specified length of time before continuing rule processing.

Processing control consists of the construction of rules with more than 16 tokens, and outpulse rule execution.

Each ISDN supporting token is described in detail below. They are listed alphabetically.

GLARE [xx]

Token type—Processing control. Use this token in impulse rules to execute a specified impulse rule when an ISDN glare condition occurs. Refer to Chapter 4, “Call Examples,” for an explanation of glare. The GLARE [xx] token must always be the first token in the rule, where [xx] specifies the number of the impulse rule to execute. Possible values for this field are 1 to 255.

ISDN RX [xx]

Token type—Supervision control. Use this token in either impulse or outpulse rules to specify the ISDN message template for rule processing. Use a value from 1 to 96 in the additional data entry field to specify the number of the ISDN message template to be processed. The template you specify must be configured as an ISDN receive message template and cannot have a message type of CHAINED. At the time of data entry, if the template number corresponds to a template that has been configured as a transmit template, an error message is displayed on the screen.

In addition, you can use this token in an impulse rule to specify which ISDN receive message template is to be used to handle incoming D-channel message processing. When the system encounters an ISDN RX [xx] token, processing continues with the template specified in the additional data field. Template processing is not completed until the message specified in the template is received. When template processing ends, rule processing continues with the token following ISDN RX [xx].

The receive template stores received D-channel message data in that call record and/or condition reporting of the received D-channel message to the host.

In outpulse rules, ISDN RX [xx] tokens function as setup tokens for ISDN SUP [xx] tokens. Rule processing does not wait for the messages specified in the ISDN message template to be received. Instead, the ISDN RX [xx] and the ISDN SUP [xx] token determine how the D-channel message is reported and stored.

ISDN SUP [xx]

Token type—Supervision control. Use this token in outpulse rules to specify the ISDN supervision template for outpulse rule processing, where [xx] is the number of the template. Template numbers range from 1 to 24.

Outpulse rule processing waits for an event to occur when this token is processed. When an event, or events, are detected that satisfy the specified ISDN supervision template, outpulse rule processing continues with the token following the ISDN SUP [xx].

ISDN TX [xx]

Token type—Supervision control. Use this token in either impulse or outpulse rules to specify the ISDN message template for constructing outgoing D-channel messages, where [xx] is the number of the template. Template numbers range from 1 to 96.

A transmitted D-channel message can be constructed by any combination of data from the following sources:

- Information elements (IEs) specified in the message template
- Data stored in system fields (ANI, 1 through 4)
- IEs specified in an ISDN Port Control (\$49) command

**Note**

IEs are the elements in D-channel messages that contain the additional information needed for call processing, such as calling party number, called party number, and channel ID. IEs vary depending on the message, action being performed, and connected equipment.

The template you specify must be an ISDN transmit message template and it cannot have a message type of CHAINED. If the template number corresponds to a template that has been configured as a receive template at the time of data entry, an error message is displayed on the screen.

When template processing ends, rule processing continues with the token following the ISDN TX [xx] token.

NOHOST [xx]

Token type—Processing control. Use this token in impulse rules to execute a specified impulse rule following the expiration of the Host Setup Timer. If the system does not receive a host command before the timer expires, it executes the impulse rule indicated in the NOHOST token's [xx] data field. Impulse rules are from 1 to 255.

If you disable the Host Setup Timer, the NOHOST token does not get executed; the system waits indefinitely for the host to respond before continuing. If you enable the Host Setup Timer, the NOHOST token is not used; the system automatically performs a RELEASE when the timer expires.

An overview of ISDN impulse and outpulse rule processing is provided in Chapter 3, "ISDN Processing Overview," including the FLD, I FLD, and D FLD digit field types used by ISDN call processing. The interaction among rule, template, and command/report processing is illustrated by the examples in Chapter 4, "Call Examples."

NOHOST [xx] is not a valid token for outpulse rules.

Refer to the *Cisco VCO/4K System Administrator's Guide* for information on defining impulse and outpulse rules.

ISDN Receive and Transmit Message Templates Summary

Use the ISDN Message Template Summary screen to do the following:

- View a listing of all messages for which a template has been defined.
- Determine whether the template is an ISDN Receive Message Template (R) or an ISDN Transmit Message Template (T).
- Access the ISDN Message Template screens.

You can define up to 96 templates for use in rule processing of ISDN calls. Template processing is reported to the host via the ISDN Impulse Rule Complete (\$ED) and ISDN Port Change of State (\$EA) reports. When reporting is done in conjunction with impulse or outpulse rule processing, timing of the reports is controlled by the reporting control tokens contained in the rule, or by the supervision template.

To access the ISDN Message Template Summary screen from the Database Administration menu, type **K** and press **Enter**. The ISDN Message Template Summary screen is displayed (see Figure 2-5). The cursor is located in the DSP (display) field corresponding to Message Template 1.

**Note**

An ISDN feature must be installed in order to access any ISDN System Administration screens.

Figure 2-5 ISDN Message Template Summary Screen

I S D N M E S S A G E T E M P L A T E S U M M A R Y											
NO	MESSAGE	R/T	DSP	NO	MESSAGE	R/T	DSP	NO	MESSAGE	R/T	DSP
1	_____	-	-	17	_____	-	-	33	_____	-	-
2	_____	-	-	18	_____	-	-	34	_____	-	-
3	_____	-	-	19	_____	-	-	35	_____	-	-
4	_____	-	-	20	_____	-	-	36	_____	-	-
5	_____	-	-	21	_____	-	-	37	_____	-	-
6	_____	-	-	22	_____	-	-	38	_____	-	-
7	_____	-	-	23	_____	-	-	39	_____	-	-
8	_____	-	-	24	_____	-	-	40	_____	-	-
9	_____	-	-	25	_____	-	-	41	_____	-	-
10	_____	-	-	26	_____	-	-	42	_____	-	-
11	_____	-	-	27	_____	-	-	43	_____	-	-
12	_____	-	-	28	_____	-	-	44	_____	-	-
13	_____	-	-	29	_____	-	-	45	_____	-	-
14	_____	-	-	30	_____	-	-	46	_____	-	-
15	_____	-	-	31	_____	-	-	47	_____	-	-
16	_____	-	-	32	_____	-	-	48	_____	-	-

50663

The ISDN Message Template Summary screen consists of two screens; each screen lists 48 message templates in numerical order. Use the keyboard to move within the screen and between the two screens.

Press **Prev Field** and **Next Field** to move between DSP fields in the same column. Press **Tab** and **<** to move between the first DSP fields in each column. Press **Prev Screen** and **Next Screen** to page through the listings. Press **Print Screen** to obtain a hard copy of any of the screens.

ISDN Message Template Summary Screen Field Definitions

The ISDN Message Template Summary screen contains the following fields:

NO—*Display only*. Template number. Templates are listed in ascending order, from 1 to 96.

MESSAGE—*Display only*. The ISDN message for which the template is configured. Change this value through the ISDN Message Templates screen. Possible values for this field are listed under the definition of the MESSAGE field for that screen.

R/T—*Display only*. Indicates whether the template is an ISDN Receive Message Template (R) or an ISDN Transmit Message Template (T).

DSP—*Data entry via main keyboard, access to another screen(s)*. This is the Display Template field. It provides access to the ISDN Message Template screens. To display another screen, type any character on the main keyboard, then press **Enter**. Refer to the “Accessing Other Menus and Screens from the ISDN Message Template Summary Screen” section on page 2-20 for instructions on using this field.

Accessing Other Menus and Screens from the ISDN Message Template Summary Screen

You can access the following screens from the ISDN Message Template Summary screen:

- Main menu—Press the **Main Menu** key.
- Database Administration menu—Press the **Prev Menu** or the **Exit** key.
- ISDN Message Template screen—Use the **Prev Field**, **Next Field**, **Tab**, or < key to position the cursor in the DSP field corresponding to the message template you want to display or edit. Then type any character and press **Enter**.

ISDN Message Templates

Use the ISDN Message Templates screen to configure up to 96 templates for use in rule processing for ISDN calls. There are two kinds of ISDN message templates: receive and transmit.

ISDN Receive Message Templates control the processing, storing, and reporting of specific D-channel messages received during inpulse or outpulse rule processing of an ISDN RX [xx] token. ISDN Transmit Message Templates control the construction and transmission of specific D-channel messages during inpulse or outpulse rule processing of an ISDN TX [xx] token.

You can set up multiple templates for a single ISDN message type. Specify the template to be used in rule processing in a data field—the receive/transmit template (R/T) designation determines whether it can be used with the ISDN RX [xx] or ISDN TX [xx] token, where [xx] is the data field containing the receive/transmit template designation. Refer to Chapter 3, “ISDN Processing Overview,” for additional information on these tokens and rule processing for ISDN.

You can access the ISDN Message Templates screen from the ISDN Message Template Summary screen. Use the **Prev Field** or **Next Field** key to position the cursor in the DSP field that corresponds to the ISDN message template that you want to display configuration information. Then type any character and press **Enter**. The ISDN Message Templates screen is displayed (see Figure 2-6).

Figure 2-6 ISDN Message Templates Screen

I S D N M E S S A G E T E M P L A T E S											
Tpl	Message	R/T	Tpl	Message	R/T	Tpl	Message	R/T	Tpl	Message	R/T
1	_____	-	2	_____	-	3	_____	-	4	_____	-

50564

There are 24 screens; each screen contains 4 template listings. The displayed screen is that of the selected template. The cursor is located in the Message field. Use the keyboard to move within the screen and between the 24 screens. Press the **Prev Field** and **Next Field** keys to page through the listings. Press the **Tab** and < keys to move between templates. Press **Print Screen** to obtain a hard copy of any of the screens.

Because of the number of templates available, it is often easier to return to the ISDN Message Template Summary screen and select the desired template, rather than page through template listings. To save the template information already displayed, press **Enter** before leaving the ISDN Message Templates screen.

ISDN Message Templates Screen Field Definitions

The ISDN Message Templates screen contains the following fields:

Tpl—*Display only*. Indicates the ISDN Message Template listing displayed. Valid ISDN message template numbers are 1 to 96.

Message—*Data entry via Select or Rev Select key or main keyboard*. Specifies the ISDN message for which the template is defined. For the standard messages listed in Table 2-14, use the **Select** and **Rev Select** keys to specify the message. You can also type the two digit hexadecimal values corresponding to these messages into the space. Table 2-14 represents the only messages that can be controlled by the host or ISDN message templates. Other ISDN messages trigger autonomous processing in the system; refer to Chapter 3, “ISDN Processing Overview,” for more information. Definitions for ISDN messages are contained in the International Telecommunications Union document *ITU-T Q.931*. Messages can be used for either transmit or receive unless otherwise specified.

Table 2-14 Standard ISDN Messages

Value	Meaning	Hexadecimal Value
CHAINED	Used to indicate this template is called by another message template	Not applicable
ALERTING	Alerting; call establishment	01
CALLPROC	Call proceeding; call establishment	02
CONNECT	Connect; call establishment	07
CONN ACK	Connect acknowledge; call establishment	0F
PROGRESS	Progress; call establishment	03
SETUP	Setup; call establishment	05
DISC	Disconnect; call clearing (transmit only) ¹	45
RELEASE	Release; call clearing (transmit only) ¹	4D
RLS CMPL	Release complete; call clearing (transmit only) ¹	3A
USERINFO	User information; call information phase	20
CONGEST	Congestion control; miscellaneous	79
FACILITY	Facility; miscellaneous	62
FACILACK	Facility acknowledge; miscellaneous	6A
FACILREJ	Facility reject; miscellaneous	72
REGISTER	Register; miscellaneous	64
NOTIFY	Notify; miscellaneous	6E
INFO	User information; call information	7B
SETUPACK	Setup acknowledge; call establishment	0D

1. System call processing handles disconnect and release processing autonomously. Control over these events is provided via the ISDN Port Control (\$49) command. These messages are provided to allow additional call control.

R/T—*Data entry via Select or Rev Select key and main keyboard.* Specifies whether the template is an ISDN Receive Message Template (R) or an ISDN Transmit Message Template (T). For transmit processing, the system automatically populates the connect length byte for each IE constructed. When the Channel ID IE is transmitted, the system automatically ensures that the B-channel is correctly specified. When the Channel ID IE is specified, the B-channel designator byte must be present.

Data Entry Fields—*Data entry via Select or Rev Select key and main keyboard.* Fifteen lines are displayed under each Tmpl, Message, R/T heading. Each of these lines contains two data entry fields. The first field is the action token field, the second is the optional IE/data field. The action token specifies the type of processing to be performed. The IE/data field specifies the D-channel message information element on which the action token operates. Action tokens, and their associated IE/data values are defined in the “Action Tokens” section on page 2-23.

Action Tokens

Action tokens specify the type of processing that is to be performed on D-channel message IEs. The action tokens are divided into six functional groups—report control, IE storage control, processing control, transmission control, codeset shift control, and the template control group.

Report Control

Report Control tokens specify the data that gets reported to the host computer. Timing of those reports is controlled by impulse or outpulse rule reporting control tokens in the rule from which the ISDN Message Template is called.

IE Storage Control

Information Element (IE) Storage Control tokens specify where the IEs are stored, and the storage format.

Processing Control

Processing Control tokens determine whether the system processes specific information elements without interaction from the host computer.

Transmission Control

Transmission Control tokens determine how the information is formatted for transmission—as information elements, or as hexadecimal bytes. These tokens are supported in ISDN Transmit templates only.

Codeset Shift Control

Codeset Shift Control tokens determine whether there is a shift to another codeset during template processing. All action tokens are assumed to be codeset 0 unless they are preceded by a CODESET token.

**Note**

Codesets are used to map one hexadecimal value to several entities. For example, in Codeset 0, hexadecimal 70 is CD NUM (called number). However, in another codeset, hexadecimal 70 may represent an entirely different entity. Codesets are typically vendor specific, and it is beyond the scope of this manual to discuss them. Refer to the International Telecommunications Union document *ITU-T Q.931* or Northern Telecom documentation for further information on codesets.

Template Control

Template Control tokens allow you to construct a message template with more than 15 tokens.

Display action tokens by pressing the **Select** and **Rev Select** keys while the cursor is located in a Data Entry field of the ISDN Message Templates screen. Specify values for the associated IE/data field by using either the **Select** and **Rev Select** keys, or by typing the data in the field. When entered via the keyboard, up to four bytes of data can be specified in this field.

In addition, you can specify values for the associated IE/data field either by using the **Select** and **Rev Select** keys or by typing the data using the main keyboard. When entered via the main keyboard, up to four bytes of data can be specified in this field. Definitions for ISDN IEs are contained in the International Telecommunications Union document *ITU-T Q.931*. A unique IE can be entered as a single hexadecimal byte, if necessary.

The following sections describe the action tokens in greater detail. Each action token is defined in three ways—by functional group, template group it is applicable to (R or T, for receive or transmit template respectively), and a detailed description. They are listed in the order in which they appear as selections.

IE Action Tokens

Functional group—Transmission control; T.

The IE action token specifies that a complete IE is to be constructed for transmission in the D-channel message for which the template is defined. An IE action token can be followed by additional data; this is specified with D FLD and DATA action tokens. The system does not check to assure that the data specified is appropriate for the IE specified in the IE/data field.

Possible IE/data field values include the IEs listed in Table 2-15 or a one-digit or two-digit hexadecimal value.

Table 2-15 ISDN Selectable Information Elements (CODESET 0)

Information Element	Meaning	Hexadecimal Value
BEARER	Bearer Capability	04
CAUSE	Cause	08
CONN NUM	Connected Number	0C
CALL ID	Call Identity	10
CALL ST	Call State	14
CHNGSTAT	Change Status	01
CHAN ID	Channel Identification	18
PROGRESS	Progress Indicator	1E
CP NUM	Calling Party Number	6C
FACILITY	Facility	1C
SIGNAL	Signal	34
CP SADDR	Calling Party Subaddress	6D
CD NUM	Called Party Number	70
CD SADDR	Called Party Subaddress	71
RD NUM	Redirect Number	74
TRNETSEL	Transit Network Selection	78
LL CMPAT	Low Layer Compatibility	7C
HL CMPAT	High Layer Compatibility	7D
USR-USR	User-User	7E
MOREDATA	More Data	A0
CNGCT RR	Congest Receiver Ready	B0

Table 2-15 ISDN Selectable Information Elements (CODESET 0) (continued)

Information Element	Meaning	Hexadecimal Value
CNGSTRNR	Congest Receiver Not Ready	BF
NET FAC	Network-Specific Facility	20
NTFY IND	Notification Indicator	27
BLOCK CH	Blocking Channel ID	03
KEYPAD	Keypad Facility	2C
FEAT ACT	Feature Activation	38
FEAT IND	Feature Indication	39
SEND_CMP	Sending Complete	A1

DATA Action Token

Functional group—Transmission control; T.

The DATA action token specifies that hexadecimal bytes are to be used to construct an IE for transmission in the D-channel message for which the template is defined. These hexadecimal bytes are transmitted exactly as they are specified on the screen.

Use each DATA action token to specify up to four hexadecimal bytes. You can construct longer data strings by using multiple DATA action tokens in a template; the DATA tokens must appear in the order in which the hexadecimal bytes are to be sent.

DATA action tokens must be preceded by an I FLD or IE action token. It can precede D FLD action tokens.

Valid IE/data field values are up to four hexadecimal bytes. When you use a DATA action token to construct an IE header, you don't specify the length bytes—system processing automatically inserts the correct IE length byte when the message is transmitted.

When you use a DATA action token to construct a channel ID IE, specify the B-channel ID as 00. The system ensures that the correct B-channel designation is used.

In NFAS applications, the interface ID is automatically inserted. If the interface ID is specified by the host, the system verifies it. If the interface ID is found to be incorrect, the specified message is not transmitted. Indication of this error condition is provided to the host in an ISDN Port Change of State (\$EA) report with the following values: Change byte = \$08, Event Code = \$00, Status Code = \$A4.

FLD Action Tokens

Functional group—IE storage control; R and T.

For receive templates, FLD action tokens specify that the complete IE (header and data) identified in the IE/data field is to be stored in a field. IEs are stored in the format in which they are received. There are five different FLD action tokens to indicate the field in which to store the IE. These tokens and the maximum number of bytes each field can store are listed in Table 2-16.

Table 2-16 FLD Action Tokens

Value	Storage Field Length
ANI	24 bytes
FLD 1	35 bytes
FLD 2	35 bytes
FLD 3	35 bytes
FLD 4	84 bytes

If the received field length is greater than the storage field length, the data is truncated. No indication of truncation for storage is provided to the host.

If the IE is reported to the host, the entire received IE is reported up to a maximum report length of 255 bytes (including the network header segment). Possible IE/data field values for receive templates include those listed in Table 2-15.

For transmit templates, FLD action tokens specify that the complete IE (header and data) stored in the field is to be transmitted in the D-channel message for which the template is defined. Because an IE can be placed into a field only as a result of processing a Receive template that contained an FLD action token or an ISDN Port Control (\$49) command that specifies FLD data, it is assumed an FLD action token always contains a complete IE.

No IE/data field entry is allowed for this token when it is used in a transmit template.

I FLD Action Tokens

Functional group—IE storage control; R and T.

For receive templates, I FLD action tokens specify that the header (intermediate) information for the IE identified in the IE/data field is to be stored in a field. This header, or intermediate, information consists of the hexadecimal bytes which precede the digit or information bytes in the IE. This includes the IE identifier and IE length bytes. IE headers are stored in the format in which they are received. There are five different I FLD action tokens to indicate the field in which to store the IE header. These tokens and the maximum number of bytes each field can store are listed in Table 2-17.

Table 2-17 I FLD Action Tokens

Value	Storage Field Length
I ANI	24 bytes
I FLD 1	35 bytes
I FLD 2	35 bytes
I FLD 3	35 bytes
I FLD 4	84 bytes

The possible IE/data field values for this action token are CP NUM, CP SADDR, CD NUM, CD SADDR, RD NUM and USR-USR. If it is used for any other IE, the IE identifier and length are stored. Appendix A, “Valid Information Elements for I FLD and D FLD Action Tokens,” contains examples of the valid IEs, showing the information that would be stored in an I FLD.

For transmit templates, I FLD action tokens specify that the IE header is to be transmitted in the D-channel message for which the template is defined. Because IE data can be placed into a field only as a result of processing a receive template that contained an I FLD token or an ISDN Port Control (\$49) command that specifies I FLD data, it is assumed an I FLD action token always contains an IE header.

I FLD action tokens must be followed by one or more D FLD or DATA tokens. This allows for construction of complete IEs from separate IE header and information fields. The system automatically populates the length byte with the correct value when IEs are constructed in this manner.

No IE/data field entry is allowed for this token when it is used in a transmit template.

D FLD Action Tokens

Functional group—IE storage control; R and T

For receive templates, D FLD action tokens specify that only the data portion (following the header) of the IE identified in the IE/data field is to be stored in a field. Data is stored in the format in which it is received. There are five different D FLD action tokens to indicate the field in which to store the information. These tokens and the maximum number of bytes each field can store are listed in Table 2-18.

Table 2-18 D FLD Action Tokens

Value	Storage Field Length
D ANI	24 bytes
D FLD 1	35 bytes
D FLD 2	35 bytes
D FLD 3	35 bytes
D FLD 4	84 bytes

If the received field length is greater than the storage field length, the data is truncated. No indication of truncation for storage is provided to the host.

The possible IE/data field values for this token are CP NUM, CP SADDR, CD NUM, CD SADDR, RD NUM and USR-USR. Specifying any other value in the IE/data field results in no information being stored in the specified D FLD. Appendix A, “Valid Information Elements for I FLD and D FLD Action Tokens,” contains examples of the valid IEs, showing the information that would be stored in a D FLD.

For transmit templates, D FLD tokens specify that the data contained in the field is to be used to construct an IE for transmission in the D-channel message for which the template is defined. Data can be placed into this field as the result of processing a receive template that contained a D FLD token, an impulse rule that contained an IP ANI [xx] or IP FIELD [xx] token, or an ISDN Port Control (\$49) command that specifies D FLD data.

Data in this field is formatted correctly for transmission over the D-channel, regardless of the format in which it was stored. Transmit D FLD tokens must be preceded by an IE or DATA token, or an I FLD token to specify the IE header information (which includes the IE identifier).

No IE/data field entry is allowed for this token when it is used in a transmit template.

CODESET Action Token

Functional group—Codeset shift control; R and T.

The CODESET action token specifies that all action tokens and information that follows is specified according to the codeset number indicated in the IE/data field. The default codeset used by the system is 0.

The codeset number returns to 0 when the system processes a new template as the result of a GO TMP or DO TMP action token. Once you use a CODESET action token in a template, you must enter subsequent entries requiring specification of an IE in hexadecimal.

Possible IE/data field values are 1 to 7.

GO TMP Action Token

Functional group—Template control; R and T.

Use the GO TMP action token to instruct the system to perform processing for the ISDN message template you specify. This allows you to construct message templates with more than 15 steps. When template processing encounters this action token, processing continues with the first token of the message template you specified in the IE/data field. Processing does not return to the calling template. Consider the following important points when using the GO TMP action token:

- GO TMP tokens cannot specify the template number in which they are listed.
- Receive templates can only refer to receive templates; transmit templates can only refer to transmit templates.
- The called template must have a message type of CHAINED.

Possible IE/data field values are 1 to 96.

DO TMP Action Token

Functional group—Template control; R and T.

Use the DO TMP action token to instruct the system to perform processing for the ISDN message template specified, and then return to this template. This allows you to construct message templates with more than 15 steps. When template processing encounters this token, processing continues with the first token of the message template specified in the IE/data field. At the end of the specified template, processing continues with the token following the DO TMP action token in the original message template. Consider the following important points when using the DO TMP action token:

- DO TMP action tokens cannot specify the template number in which they are listed.
- The subroutine must not call another template containing a DO TMP action token.
- Receive templates can only refer to receive templates; transmit templates can only refer to transmit templates.
- The called template must have a message type of CHAINED.

Possible IE/data field values are 1 to 96.

REP Action Token

Functional group—Reporting control; R.

Use the REP token to indicate that the IE specified in the IE/data field should be reported to the host. If the IE is not received, a status byte in the report indicates that not all expected IEs were received. The entire received IE is reported to the host.

If the ISDN Impulse Rule Complete (\$ED) or ISDN Port Change of State (\$EA) report length exceeds 255 bytes, it is truncated. A status byte in the \$ED report indicates that the report has been truncated. No indication of truncation is provided for the \$EA report.

Possible IE/data field values include the IEs listed in Table 2-15.

REP ALL Action Token

Functional group: reporting control; R.

The REP ALL action token specifies that all IEs contained in the received message should be reported to the host. The entire received IE is reported to the host.

If the ISDN Impulse Rule Complete (\$ED) report or ISDN Port Change of State (\$EA) report length exceeds 255 bytes, it is truncated. A status byte in the \$ED report indicates truncation has been performed. No indication of truncation is provided for the \$EA report.

Use of this token does not preclude the use of NO REP in the same template. When NO REP is used in the same template as REP ALL, the specified IE is not reported to the host if received.

No IE/data field entry is allowed for this token.

NO REP Action Token

Functional group—Reporting control; R.

The NO REP token is used in conjunction with REP ALL to specify that the specific IE contained in the IE/data field should not be reported to the host.

Valid IE/data field values include the IEs listed in Table 2-15.

PROCESS Action Token

Functional group—Reporting control; R.

The PROCESS action token is used to specify that the IE contained in the IE/data field should be processed by the system. The only IE processed autonomously is CHAN ID (Channel ID). When this token is processed, the system selects the appropriate B-channel based on the coding of the received IE and the state of the B-channel. If the IE is not received, a status byte in the report indicates that not all expected IEs were received and no B-channel selection is performed.

The B-channel selection is based on Class of Service (COS) and port state. The system selects a port that is in service, idle, and has a COS of either 2 (2-way) or T (terminating/incoming). When a B-channel has been assigned due to a PROCESS token, the port address of the selected B-channel is reported to the host in an ISDN Impulse Rule Complete (\$ED) or ISDN Port Change of State (\$EA) report.

If you use the **Select** and **Rev Select** keys, CHAN ID is the only value that can be displayed.

Adding an ISDN Message Template

To add an ISDN message template, complete the following steps:

- Step 1** Display the ISDN Message Templates screen (refer to the “ISDN Message Templates” section on page 2-20). The cursor is located in the Message field of the first template on the screen.
- Step 2** Use the **Prev Screen**, **Next Screen**, **Tab**, and < keys to advance the cursor to the Message field of the template you want to add.

- Step 3** Use the **Select** and **Rev Select** keys to step through the token listing until the correct token is displayed, or type the correct value. Press **Next Field**. The cursor moves to the R/T field.
- Step 4** Type either R or T (or display the correct value by using the **Select** and **Rev Select** keys) and press **Next Field**. The cursor moves to the first Action field for that template field.
- Step 5** Use the **Select** and **Rev Select** keys to step through the token listing until the correct token is displayed, or type the correct value. Press **Next Field**.
- If the token you selected has no IE/data value, the cursor moves to the next Action field and you are ready to select that token.
 - If the token you selected has an action field value, use the **Select** and **Rev Select** keys to step through the token listing until the correct token is displayed *or* type the correct information. Then press the **Next Field** key. The cursor moves to the next Action field and you are ready to specify that token.
- Step 6** Repeat Step 5 until all action tokens and values for the template are displayed on the screen, then press **Enter**. The database is automatically updated.
- Step 7** Repeat Steps 2 through 6 for all ISDN message templates you want to add.
- Step 8** When all ISDN message templates are entered, press **Exit** to return to the ISDN Message Template Summary screen.
- To leave the ISDN Message Templates screen without making any changes, press **Exit**, **Prev Menu**, or **Main Menu**. No changes are made to the database unless you press **Enter**.
-

Deleting an ISDN Message Template

To delete an ISDN message template, complete the following steps:

-
- Step 1** Display the ISDN Message Templates screen (refer to the “ISDN Message Templates” section on page 2-20). The cursor is located in the Message field of the first template on the screen.
- Step 2** Use the **Prev Screen**, **Next Screen**, **Tab**, and < keys to advance the cursor to the Message field of the template you want to delete.
- Step 3** Use the **Prev Field** and **Next Field** keys to advance the cursor to the first Action field.
- Step 4** Use the **Select** and **Rev Select** keys to step through the token listing until a blank line is displayed, or use the space bar to type blank spaces over the token. Press the **Next Field** key. The cursor advances to the next action token field in the rule.
- Step 5** Repeat Step 4 until all fields in the template are blank, then press **Enter**. The database is automatically updated.
- Step 6** Repeat Steps 2 through 4 for each template you want to delete.
- Step 7** Press **Exit** to return to the ISDN Message Template Summary screen.
- To leave the ISDN Message Templates screen without making any changes, press **Exit**, **Prev Menu**, or **Main Menu**. No changes are made to the database unless you press **Enter**.
-

Adding an Action Token to an ISDN Message Template

To add an action token to an existing ISDN message template, complete the following steps:

-
- Step 1** Display the ISDN Message Templates screen (refer to the “ISDN Message Templates” section on page 2-20). The cursor is located in the Message field of the first template on the screen.
 - Step 2** Use the **Prev Screen**, **Next Screen**, **Tab**, and < keys to advance the cursor to the Message field of the template you want to add.
 - Step 3** Use the **Prev Field** and **Next Field** keys to advance the cursor to the Action field preceding the one into which you want to insert the token.
 - Step 4** Press the **Insert** key. All action tokens, including that field, and the cursor, move down one line. Press the **Prev Field** key to move the cursor into the blank field.
 - Step 5** Use the **Select** and **Rev Select** keys to step through the token listing until the correct action token is displayed. Press the **Next Field** key.
 - If the action token you selected has no IE/data value, the cursor moves to the next Action field and you are ready to select that token.
 - If the action token you selected has an action value, use the **Select** and **Rev Select** keys to step through the token listing until the correct action token is displayed or type the correct information. Then press the **Next Field** key. The cursor moves to the next Action field and you are ready to specify that token.
 - Step 6** Repeat Steps 3 through 5 for each token you want to add.
 - Step 7** When all action tokens have been added, press **Enter** to automatically update the database.
 - Step 8** Press **Exit** to return to the ISDN Message Template Summary screen.

To leave the ISDN Message Templates screen without making any changes, press **Exit**, **Prev Menu**, or **Main Menu**. No changes are made to the database unless you press **Enter**.
-

Deleting an Action Token from an ISDN Message Template

To delete an action token from an existing ISDN message template, complete the following steps:

-
- Step 1** Display the ISDN Message Templates screen (refer to the “ISDN Message Templates” section on page 2-20). The cursor is located in the Message field of the first template on the screen.
 - Step 2** Use the **Prev Screen**, **Next Screen**, **Tab**, and < keys to advance the cursor to the Message field of the template from which you want to delete a token.
 - Step 3** Use the **Prev Field** and **Next Field** keys to advance the cursor to the Action field from which you want to delete the token.
 - Step 4** Use the **Select** and **Rev Select** keys to step through the token listing until a blank line is displayed, or use the space bar to type blank spaces over the token. To delete more than one token in a template, advance to that token and change it to a blank line. This action also clears the corresponding IE/data field. Press **Enter**. The database is automatically updated and the screen display is updated to show the deletion of the action token(s) and its associated IE/data field(s).

Step 5 Repeat Steps 3 and 4 for each template from which you want to delete one or more action tokens.

Step 6 Press **Exit** to return to the ISDN Message Template Summary screen.

To leave the ISDN Message Templates screen without making any changes, press **Exit**, **Prev Menu**, or **Main Menu**. No changes are made to the database unless you press **Enter**.

Accessing Other Menus and Screens from the ISDN Message Templates Screen

You can access the following screens from the ISDN Message Templates screen:

- Main menu—Press the **Main Menu** key.
- Database Administration menu—Press the **Prev Menu** key.
- ISDN Message Template Summary screen—Press the **Exit** key.
- ISDN Supervision Templates screen—Press **Exit**, which brings you to the ISDN Message Template Summary screen. Press **Exit** again, and press **J**.

ISDN Supervision Templates

Use the ISDN Supervision Templates screens to configure up to 24 supervision templates for use with the ISDN SUP [xx] outpulse rule token. Each template defines a set of system responses to the detection of specific ISDN messages, such as ALERTING, CONNECT, PROGRESS, and CALL PROC (call proceeding).

Use condition tokens to specify individual system responses to these messages, or events. These responses include reporting, propagation of the message to the incoming port, call failure, or error condition reporting.

ISDN calls are not marked stable when a template is being executed unless the template specifies to do so. Generally, the receipt of a CONNECT message causes the state of the port to go stable.

After the end of an outpulse rule and before receipt of a CONNECT message, the system reports all received D-channel messages (IEs and messages) to the host as supervision outside an outpulse rule (change byte = \$08) in an ISDN Port Change of State (\$EA) report. When the system receives an ISDN CONNECT message, the call is considered answered and changes to stable. The ISDN CONNECT message is also propagated back to the incoming port if the incoming port is not considered answered.

To access the ISDN Supervision Templates screen (see Figure 2-7) from the Database Administration menu, type **J** and press **Enter**. There are three screens; each contains eight template listings. The displayed screen is that of the selected template. The cursor is located in the Time token field of Template 1.

Press **Prev Screen** and **Next Screen** to page through the listings. Press **Tab** and < to move between the templates. Press **Print Screen** to obtain a hard copy of any of the screens.



Note

A version of ISDN must be installed in order to access any ISDN System Administration screen.

Figure 2-7 ISDN Supervision Templates Screen

	1	2	3	4	5	6	7	8
TIME	_____	_____	_____	_____	_____	_____	_____	_____
ALERTING	_____	_____	_____	_____	_____	_____	_____	_____
CONNECT	_____	_____	_____	_____	_____	_____	_____	_____
PROGRESS	_____	_____	_____	_____	_____	_____	_____	_____
CALLPROC	_____	_____	_____	_____	_____	_____	_____	_____
CONN ACK	_____	_____	_____	_____	_____	_____	_____	_____
USERINFO	_____	_____	_____	_____	_____	_____	_____	_____
CONGEST	_____	_____	_____	_____	_____	_____	_____	_____
FACILACK	_____	_____	_____	_____	_____	_____	_____	_____
FACILREJ	_____	_____	_____	_____	_____	_____	_____	_____

50665

ISDN Supervision Templates Screen Field Definitions

The ISDN Supervision Templates screen contains nine columns of data. The leftmost column contains ten event fields, which we refer to as the Events Column. The remaining columns have eleven fields each—they begin with a template number at the top, followed by ten data entry fields below—which we refer to as Template Number Columns. As you can see in Figure 2-7, there are eight Template Number Columns. The Events Column and the Template Number Columns are described as follows:

Events Column—*Display only.* For the first event, TIME, identifies a timer event for which an action is specified. The remaining event fields identify the ISDN message for which an action is specified. The event values are listed in Table 2-19. Definitions for ISDN messages are contained in the International Telecommunications Union document *ITU-T Q.931*.

Table 2-19 ISDN Supervision Templates Event Values and Meanings

Value	Meaning
TIME	Expiration of a timer and ISDN message. When an ANSBK or ANSREP token is specified, the timeout functions as a grace timer. When an ERROR or FAIL condition token is specified, the timeout indicates a supervision error or a call failure, respectively. The timer is started when supervision template processing begins and cancelled when an event is detected. The timer's duration is specified in a preceding TIME SUP [xx] outputpulse rule token. If no token is specified, timing is not performed.
ALERTING	Alerting; call establishment.
CONNECT	Connect; call establishment.
PROGRESS	Progress; call establishment.
CALLPROC	Call proceeding; call establishment.

Table 2-19 ISDN Supervision Templates Event Values and Meanings (continued)

Value	Meaning
CONN ACK	Connect acknowledge; call establishment.
USERINFO	User information; call information phase.
CONGEST	Congestion control; miscellaneous.
FACILACK	Facility acknowledge; miscellaneous.
FACILREJ	Facility reject; miscellaneous.

Template Number Columns—The template numbers fields (1 to 8) are display only; the data entry fields are for your use—*Data entry via Select or Rev Select keys.*

The template number field identifies the specific template configuration for use with the ISDN SUP [xx] outpulse rule token.

The data entry fields specify the events to be detected, and consequent actions taken when each event is detected, including host reporting, propagating events, and indicating error conditions. These condition tokens define the action for the system to take when the event is detected during template processing.

Condition Tokens

Ten condition tokens specify individual system responses, and combinations of responses, to a signaling event, such as report generation. Condition tokens also use the detection of the event as an indicator of error conditions and failed calls. Condition tokens are defined for each signaling event; events are disregarded when no token is defined for the event.

Use the **Select** and **Rev Select** keys to display the condition tokens, which will vary according to supervision events. The possible tokens are described below, and listed in the order in which they appear as selections.

OK Condition Token

Indicates that an event was detected during processing of the ISDN SUP [xx] outpulse rule token. The event is not reported to the host when it occurs. When the event is detected, the ISDN SUP [xx] token is satisfied and template processing ends. Outpulse rule processing continues with the token following the ISDN SUP [xx] until the rule completes or the call goes to stable state.

OKREP Condition Token

Indicates that an event was detected during processing of the ISDN SUP [xx] outpulse rule token. An ISDN Port Change of State (\$EA) report to the host is generated. When the event is detected, the ISDN SUP [xx] outpulse rule token is satisfied and template processing ends. Outpulse rule processing continues with the token following the ISDN SUP [xx] token until the rule completes or the call goes to stable state.

ANSBK Condition Token

Valid only for the CONNECT event. Indicates that a CONNECT event was detected during processing of the ISDN SUP [xx] outpulse rule token and that answerback was sent to the incoming port (assuming it has not already been answered). The event is not reported to the host when it occurs. When the event is detected and answerback sent, the ISDN SUP [xx] outpulse rule token is satisfied and template processing ends.

Outpulse rule processing continues with the token following the ISDN SUP [xx] token until the rule completes or the call goes to stable state. Because the outgoing port is considered answered when answerback is sent, the call automatically goes to stable state when outpulse rule processing completes. For ISDN-to-ISDN calls, answerback takes the form of a CONNECT event message generated for the incoming call. Use of this token provides the correct answer supervision of non-ISDN incoming calls.

ANSREP Condition Token

Valid only for the CONNECT event. Indicates that the system detected a CONNECT event during processing of the ISDN SUP [xx] outpulse rule token and sent answerback to the incoming port (assuming it has not already been answered).

The system generates an ISDN Port Change of State (\$EA) report to the host. When the event is detected and answerback sent, the ISDN SUP [xx] outpulse rule token is satisfied and template processing ends. Outpulse rule processing continues with the token following the ISDN SUP [xx] token until the rule completes, or the call goes to stable state. Because the outgoing port is considered answered when answerback is sent, the call automatically goes to stable state when outpulse rule processing completes. For ISDN-to-ISDN calls, answerback takes the form of a CONNECT event message generated for the incoming call.

Use of this token provides the correct answer supervision for non-ISDN incoming calls.

REP Condition Token

Indicates that an event will be reported to the host when detected. An ISDN Port Change of State (\$EA) report is generated containing the event indicator. Events marked with REP condition tokens do not satisfy an ISDN SUP [xx] outpulse rule token; template processing continues until an event marked with another type of condition token is detected.

ERROR and FAIL Condition Tokens

Indicates that a signaling event has detected a failed call. The event is not considered a supervision error. The outgoing port is removed from the call and the incoming port is left in setup. The system generates an ISDN Port Change of State (\$EA) report, indicating a failed call attempt. Template processing ends when the event is detected and the outpulse rule is aborted.

QUIT Condition Token

Indicates that an event caused outpulse rule processing to abort. Template processing ends and the outgoing port returns to the state it was in prior to outpulse rule processing, but is not removed from the call. An ISDN Port Change of State (\$EA) report is generated, indicating an outpulse rule failure. The QUIT condition token event can occur at any time during outpulse rule processing, even after the port is considered answered.

PRP Condition Token

Valid only for ALERTING, PROGRESS, and CALL PROC events. Indicates that an event was detected during processing of the ISDN SUP [xx] outpulse rule token and that the event is to be propagated (sent back) to the incoming port.

If the incoming port is a non-ISDN resource, only the ALERTING message can be propagated, and the incoming port is presented with ringback tone. No report is generated. Events marked with PRP tokens do not satisfy an ISDN SUP [xx] outpulse rule token; template processing continues until an event marked with another type of condition token is detected. The CONNECT message can be propagated back to the incoming port through the ANSBK and ANSREP tokens.

PRPREP Condition Token

Valid only for ALERTING, PROGRESS, and CALLPROC events. Indicates that the system detected an event while processing the ISDN SUP [xx] outpulse rule token, and that the event is to be propagated (sent back) to the incoming port.

If the incoming port is a non-ISDN resource, only the ALERTING message can be propagated and the incoming port is presented with audible ringback tone. The system generates an ISDN Port Change of State (\$EA) report containing the event indicator. Events marked with PRPREP tokens do not satisfy an ISDN SUP [xx] outpulse rule token; template processing continues until an event marked with another type of condition token is detected.

Adding an ISDN Supervision Template

To add an ISDN supervision template, complete the following steps:

-
- Step 1** Display the ISDN Supervision Templates screen (refer to the “ISDN Supervision Templates” section on page 2-32). The cursor is located in the first token field of Template 1.
 - Step 2** Use the **Prev Screen**, **Next Screen**, **Tab**, **Prev Field**, and **Next Field** keys to advance the cursor to the first token field of the template you want to add.
 - Step 3** Use the **Select** and **Rev Select** keys to step through the condition token listing until the correct token is displayed. Press **Next Field**.
 - Step 4** Repeat Step 3 until all condition tokens for the template are displayed on the screen. Use the **Prev Screen**, **Next Screen**, **Tab**, **<**, **Prev Field**, and **Next Field** keys to advance the cursor to the first token field of any other templates you want to add. Repeat Steps 2 through 4 for all other templates.
 - Step 5** When all templates are entered, press **Enter**. The database is automatically updated.
 - Step 6** When all templates are entered, press **Exit** to return to the Database Administration menu.

To leave the ISDN Supervision Templates screen without making any changes, press **Exit**, **Prev Menu**, or **Main Menu**. No changes are made to the database unless you press **Enter**.

Deleting an ISDN Supervision Template

To delete an ISDN supervision template, complete the following steps:

-
- Step 1** Display the ISDN Supervision Templates screen (refer to the “ISDN Supervision Templates” section on page 2-32). The cursor is located in the first token field of Template 1.
 - Step 2** Use the **Prev Screen**, **Next Screen**, **Tab**, **Prev Field**, and **Next Field** keys to advance the cursor to the first token field of the template you want to delete.
 - Step 3** Use the **Select** and **Rev Select** keys to step through the condition token listing until a blank line is displayed. Press **Next Field**. The cursor advances to the next token field in the template.
 - Step 4** Repeat Step 3 until all fields in the template are blank.
 - Step 5** Repeat Steps 2 through 4 for each template you want to delete. Press **Enter** after all deletions are made. The database is automatically updated.

Step 6 Press **Exit** to return to the Database Administration menu.

To leave the ISDN Supervision Templates screen without making any changes, press **Exit**, **Prev Menu**, or **Main Menu**. No changes are made to the database unless you press **Enter**.

Adding a Condition Token to an ISDN Supervision Template

To add a condition token to an existing ISDN supervision template, complete the following steps:

-
- Step 1** Display the ISDN Supervision Templates screen (refer to the “ISDN Supervision Templates” section on page 2-32). The cursor is located in the first token field of Template 1.
- Step 2** Use the **Prev Screen**, **Next Screen**, **Tab**, **Prev Field**, and **Next Field** keys to advance the cursor to the token field into which you want to insert the token.
- Step 3** Use the **Select** and **Rev Select** keys to step through the condition token listing until the correct token is displayed. Press **Next Field**.
- Step 4** Repeat Steps 2 through 4 for each condition token you want to add.
- Step 5** When you have completed adding all condition tokens, press **Enter**. The database is automatically updated.
- Step 6** Press **Exit** to return to the Database Administration Menu.
- To leave the ISDN Supervision Templates screen without making any changes, press **Exit**, **Prev Menu**, or **Main Menu**. No changes are made to the database unless you press **Enter**.
-

Deleting a Condition Token from an ISDN Supervision Template

To delete a condition token from an ISDN Supervision Template, complete the following steps:

-
- Step 1** Display the ISDN Supervision Templates screen (refer to the “ISDN Supervision Templates” section on page 2-32). The cursor is located in the first token field of Template 1.
- Step 2** Use the **Prev Screen**, **Next Screen**, **Tab**, **Prev Field**, and **Next Field** keys to advance the cursor to the token field you want to delete.
- Step 3** Use the **Select** and **Rev Select** keys to step through the condition token listing until a blank line is displayed. If you want to delete more than one condition token in a template, advance to that token and change it to a blank line. The screen display is updated to show the deletion of the token(s).
- Step 4** Repeat Steps 2 and 3 for each template from which you want to delete one or more condition tokens. Press **Enter** after all deletions are made. The database is automatically updated.
- Step 5** Press **Exit** to return to the Data Base Administration menu.
- To leave the ISDN Supervision Templates screen without making any changes, press **Exit**, **Prev Menu**, or **Main Menu**. No changes are made to the database unless you press **Enter**.
-

Accessing Other Menus and Screens from the ISDN Supervision Template Screen

You can access the following screens from the ISDN Supervision Template screen:

- Main menu—Press the **Main Menu** key.
- Database Administration menu—Press the **Prev Menu** or **Exit** key.

Display Card Data

The Display Card Data screen fully supports the ICC ISDN span. No changes have been made to the screen fields or layout for this ISDN functionality; additional values have been added to the Card Status and Alarm States fields.



Note

Although additional values can be displayed for other span types, the span status values listed in Table 2-20 are specific to the ICC ISDN span. Alarm states for the ICC ISDN spans are listed in the “Card Alarm State Messages” section on page 2-41.

When you use the Display Card Data screen to display a ICC ISDN span, the status field indicates the status of the span's D-channel. Possible values for this field are listed in Table 2-20.

Table 2-20 ICC ISDN Span Status Values and Meanings

Value	Meaning
Active	Active
Out of Srvc	Out of Service
Maintenance	Maintenance (valid for ICC ISDN span when card alarms are present or when PRI application software is being downloaded to the card)
Diagnostic	Diagnostics (set from Card Maintenance display—ICC ISDN span is in local loopback mode)
Remote	Remote Diagnostics (set from Card Maintenance display—ICC ISDN span is in remote loopback mode)

The Display Card Data screen is fully documented in the *Cisco VCO/4K System Administrator's Guide*.

Port Display

The Port Display screen is shown in Figure 2-8.

Figure 2-8 Port Display Screen

```

                                P O R T   D I S P L A Y

RLSP:  1 1 15-1-1 1  PA ____  COS ____  TRACE: Host _  NBC _  Voice _
CURRENT STATE      In/Outpulse Rule ____  Token ____  CURRENT LINKS
Major              CP_IDLE  Resource Group ____  Conference ____  R L S   P
Supplementary 0    Listening To RLSP  _ _ _ _ _  PA _ _ _ _ _
ISDN IN-SERV  IDLE  Conf/Assoc Port RLSP  _ _ _ _ _  PA _ _ _ _ _
Call Id
Port Pointer      _____  Attempts _____
Dynamic Port Pointer _____  Completions _____
Start Record Pointer _____  Errors/Threshold ____/____
End Record Pointer _____  Rehunts/Threshold _/_ _ _ _ _

ANI ____
(1) ____
(2) ____
(3) ____
(4) ____
_____
_____
_____
_____

```

50654

Port Display Screen Field Definitions—ISDN Specific

Three fields in the Port Display screen are specific to ISDN channels—IN-SERV, which indicates the ISDN port state; IDLE, which indicates the ISDN port state's associated call state; and Call Id. These fields are described in detail below.

In addition to the three ISDN specific fields, there are the standard Port Display screen fields, which are described in the *Cisco VCO/4K System Administrator's Guide*.

IN-SERV—*Display only*. Identifies the state of the ISDN port (channel) being displayed. Possible values are listed in Table 2-21.

Table 2-21 ISDN Port State Field Values and Meanings

Value	Meaning
IN-SERV	In service. Port is currently in service and available for use in a call.
OOS-NE	Out of service, near end. Port is currently out of service due to some system action (system administration). Port is unavailable to call processing. System action is required to put the port back into service.

Table 2-21 ISDN Port State Field Values and Meanings (continued)

Value	Meaning
OOS-FE	Out of service, far end. Port is currently out of service due to some action at the far end. Port is unavailable to call processing. Action at the far end is required to put the port back into service.
MAINT-NE	Maintenance, near end. Port is currently in maintenance mode due to some system action (system administration) or signal alarm condition. Port is unavailable to processes calls.
MAINT-FE	Maintenance, far end. Port is currently in maintenance mode due to some action at the far end. Port is unavailable to call processing. Action at the far end is required to put the port back into service.

IDLE—*Display only*. Identifies the state of the ISDN call carried on the displayed port (channel). Possible values and corresponding User-Side call states and state numbers are listed in Table 2-22.

Definitions for user-side call states and state numbers are contained in the International Telecommunications Union document *ITU-T Q.931*.

Table 2-22 ISDN Call State Field Values, States, and Numbers

Value	Call State	Call State Number
IDLE	Null State	0/Rest 0
O_INITED	Call Initiated	1
I_OVERLAP or O_OVERLAP	Overlap Sending	2—reserved for future use
O_PROCEED	Outgoing Call Proceeding	3
O_DELIVRD	Call Delivered	4
I_CALLPRS	Call Present	6
I_RECEIVD	Call Received	7
I_CONNECT	Connect Request	8
I_PROCEED	Incoming Call Proceeding	9
I_ACTIVE or O_ACTIVE	Active	10
DISC_REQ	Disconnect Request	11
DISC_IND	Disconnect Indication	12
DISC_RLS	Release Request	19

CALL ID—*Display only*. Indicates the call identification assigned to this call attempt by the system. The system ensures that call identification values are unique for the life of the call. CALL ID values range from 1 to 127 for each D-channel.

Card Alarm State Messages

ICC ISDN spans are supported by the card alarm state display function. The Card Alarm Display screen displays these card alarm messages which are defined in Table 2-23. Two abbreviations, which precede each message, indicate alarm importance.

- MA indicates a major alarm.
- MI indicates a minor alarm.

The alarm state messages accommodate both ICC ISDN T1 spans and ICC ISDN E1 spans.

Refer to the *Cisco VCO/4K System Administrator's Guide* for further information on the Card Alarm Display screen. Refer to the *Cisco VCO/4K System Messages* for more information on card alarm state messages.

Table 2-23 Card Alarm State Messages and Meanings

Message	Meaning
MA PRI D-Channel Failure	The D-channel of an ICC ISDN span has been released. No calls can be placed. The D-channel gets reestablished only after all the Layer 1 alarms are cleared.
MA PRI/T1/E1 Carrier Failure	System has detected loss of carrier on an ICC ISDN span.
MA PRI/T1/E1 Card Failure	ICC ISDN T1 span or ICC ISDN E1 span has been removed from service via system administration, or NBC can no longer communicate with the span.
MA Interface Hardware Failure	A single span or service engine has failed on the ICC or SPC. The hardware needs to be replaced.
MA Wrong Hardware Installed	Incompatible hardware is installed in your system. For example, an ICC T1 I/O module may be connected to an ICC E1 span. This message pertains only to the ICC and SPC.
MA Module Hardware Failure	All spans or service engines have failed on the ICC or SPC I/O module. The hardware needs to be replaced.
MI PRI/T1/E1 Remote Alarm	Indicates receipt of remote failure indication (yellow alarm).
MI PRI/T1/E1 Out Of Frame	Indicates an out of frame (OOF) condition has been detected for an ICC ISDN T1 span or an ICC ISDN E1 card.
MI PRI/T1/E1 Blue Alarm	Indicates an AIS/Blue alarm has been detected for an ICC ISDN span. It is essentially receiving an out of frame (OOF) condition, all 1s (ones).
MI E1 CRC Error	Indicates the occurrence of E-bit error in the receiving data stream for an ICC ISDN span. This is the result of the far end having detected the Cyclic Redundancy Check 4 (CRC4) error.
MI PRI/T1/E1 OOF Maint. Limit	Indicates the maintenance threshold for the PRI/T1 out of frame (OOF) condition has been reached. For ICC ISDN E1 spans, this threshold is set through the ICC ISDN Span Configuration screen. For ICC ISDN T1 spans, this threshold is fixed at 4.

Table 2-23 Card Alarm State Messages and Meanings (continued)

Message	Meaning
MI PRI/T1/E1 Slip Maint. Limit	Indicates the maintenance threshold for PRI/T1 SLIPS has been reached. For ICC ISDN E1 spans, this threshold is set through the ICC ISDN Span Configuration screen. For T1, this threshold is fixed at 255.
MI All Ports Deactivated	Request to deactivate all the ports or an ICC ISDN span is received. This allows the administrator to perform maintenance action on the ports. No calls can be placed.



ISDN Processing Overview

System processing of ISDN D-channel messages generally follows the International Telecommunications Union guidelines documented in *ITU-T Q.931*. This chapter provides an overview of system D-channel message processing, and how it relates to the use of inpulse rules, outpulse rules, and templates. This discussion begins with a look at how ISDN D-channel messages are used to establish and clear a simple call.

D-channel messages establish and manage ISDN calls in much the same way supervision signals and call progress tones handle non-ISDN calls. Actions such as seizing a circuit or going on-hook are represented by D-channel messages such as *SETUP* and *DISCONNECT*. Figure 3-1 shows the D-channel messages used to establish and clear a simple ISDN call.

Figure 3-1 Establishing and Clearing an ISDN Call

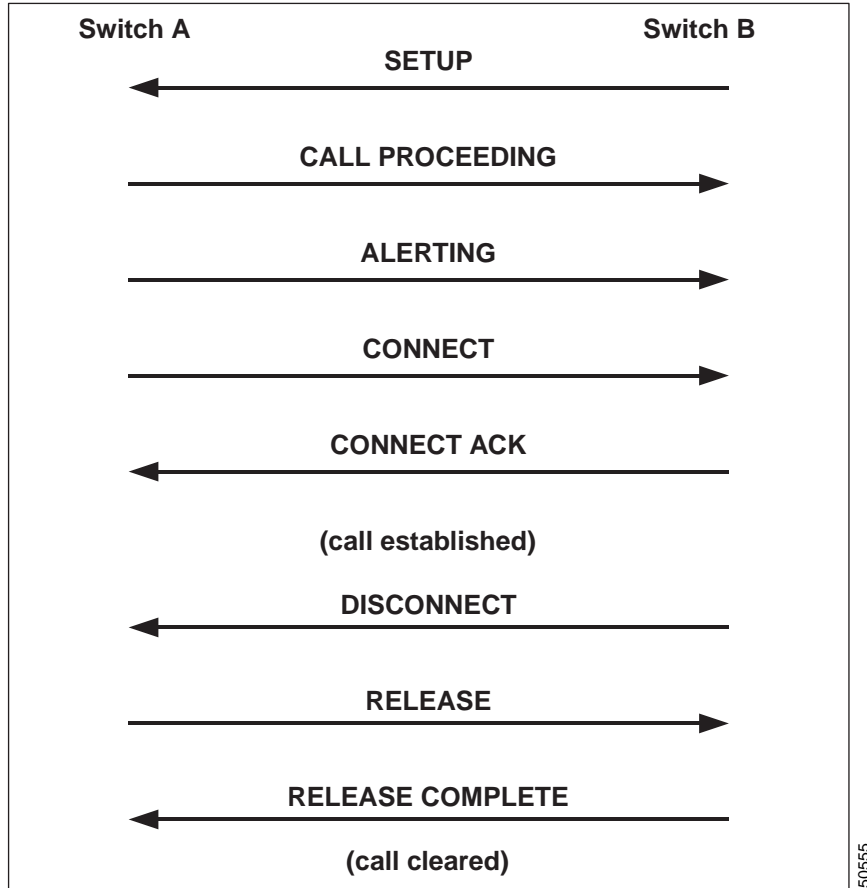

Most D-channel messages include additional information needed for call processing, such as the calling party number, called party number, and channel ID. These data, referred to as information elements (IEs), varies depending on the message, action being performed, and connected equipment. Mandatory and optional IEs for D-channel messages are defined in *ITU-T Q.931*.

Other D-channel messages are part of the standard ISDN message set. These messages allow complete control over call establishment and clearing, network maintenance, and the passing of other call-related information between switches.

The ICC card supports several ISDN protocols. The NI-2, AT&T 4ESS, AT&T 5ESS, and NTI protocol implementation supports both user-side and user-side symmetrical modes. The EURO, NTT, and TS014 protocol implementation supports user-side and network-side modes. The system also supports the symmetrical form of European ISDN, which is called the QSIG protocol.

D-channel Message Processing

The system constructs and interprets ISDN D-channel messages by using a combination of inpulse and outpulse rules, ISDN message templates, ISDN supervision templates, host commands, and host reports. Each has a specific purpose in system ISDN call processing, as follows:

- Inpulse and outpulse rules—A list of system processing instructions that are triggered by either an external event or host command.

- ISDN message templates—Called by inpulse and outpulse rules to determine how the system does the following:
 - Constructs and transmits specific D-channel messages during the processing of an ISDN TX [xx] token
 - Processes, stores, and reports specific D-channel messages it receives during the processing of an ISDN RX [xx] token.
- ISDN supervision templates—Called by the outpulse rule ISDN SUP [xx] token to determine the system's response to specific D-channel messages.
- Host commands—Used to tell the system what action to perform next, such as execute a rule or connect two B-channels.
- Host reports—Generated to inform the host of the status of a call, and to report received D-channel data.

Table 3-1 lists the standard ISDN messages as defined in the International Telecommunications Union document *ITU-T Q.931*.

Table 3-1 ISDN D-channel Messages

Message Type	Message
Call Clearing	DISCONNECT
	RELEASE
	RELEASE COMPLETE
	RESTART
	RESTART ACKNOWLEDGE
Call Establishment	ALERTING
	CALL PROCEEDING
	CONNECT
	CONNECT ACKNOWLEDGE
	PROGRESS
	SETUP
Call Information Phase	USER INFORMATION
Maintenance	SERVICE
	SERVICE ACKNOWLEDGE
Miscellaneous	CONGESTION CONTROL
	FACILITY
	FACILITY ACKNOWLEDGE
	FACILITY REJECT
	NOTIFY
	REGISTER
	STATUS
	STATUS ENQUIRY

The following sections define each of these messages and the system processing associated with them. In general, the following processing rules apply:

- The system performs mandatory received message IE verification, in accordance with *ITU-T Q.931*, for the appropriate ISDN protocol.
- The host computer is responsible for verifying received IE messages.
- The system does not ensure that transmitted D-channel messages have the correct IE content. This is the responsibility of the application designer.
- No restrictions are imposed on IE content or coding in transmitted D-channel messages.
- The system limits the length of transmitted D-channel messages, which include their D-channel headers, to 180 bytes—messages which exceed this length are truncated.
- Incoming D-channel messages are limited to a length of 180 bytes. If a received D-channel message is longer than 180 bytes, the excess bytes are lost.

ISDN D-channel Call Clearing Messages

The call clearing ISDN D-channel messages are described below.

DISCONNECT

The DISCONNECT message clears a connection. The expected response to a DISCONNECT is RELEASE. The processing of the DISCONNECT is affected by the setting of the Enable ISDN Manual Disconnect feature flag and the enabling or suppression of the ISDN Port Change of State (\$EA) report.

The enabling or suppression of the \$EA reports is controlled by disconnect control bits (D/R bits) in byte offsets 29 and 30 (disconnect control) of the ISDN Port Control (\$49) command that established the call.

The setting of the D/R bits of the \$49 command determines how the system processes transmitted DISCONNECT messages. The \$49 command should include additional and/or customized cause values and any other IEs that need to be included in the message. Although you can use the ISDN TX token and ISDN transmit message templates to transmit DISCONNECT messages, use of the control options in the \$49 command is more efficient and consistent with the use of the DISCONNECT message.

The DISCONNECT ISDN D-channel message processing, with the Enable ISDN Manual Disconnect feature flag settings and \$EA report enabled or suppressed, is summarized in Table 3-2.

Table 3-2 DISCONNECT ISDN D-channel Message Processing with the Enable ISDN Manual Disconnect Feature Flag and \$EA Report Enabled/Suppressed

Flag Setting	\$EA Report Suppressed?	DISCONNECT ISDN D-channel Message Processing
Y	No	The system reports the DISCONNECT IEs to the host via an \$EA report. The system waits 4 seconds for the host to take control of the processing of RELEASE via a \$49 command. If the host does not respond in 4 seconds, the system sends a RELEASE to the network and reports the DISCONNECT IEs to the host via an \$EA report.
Y	Yes	The system waits 4 seconds and sends a RELEASE to the network. These settings are not recommended.

Table 3-2 DISCONNECT ISDN D-channel Message Processing with the Enable ISDN Manual Disconnect Feature Flag and \$EA Report Enabled/Suppressed (continued)

Flag Setting	\$EA Report Suppressed?	DISCONNECT ISDN D-channel Message Processing
N	No	The system processes the DISCONNECT autonomously and sends a RELEASE to the network. The system also reports the DISCONNECT IEs to the host via an \$EA report.
N	Yes	The system processes the DISCONNECT autonomously and sends a RELEASE to the network. The system does not report the DISCONNECT to the host.

DISCONNECT Message and Timers T305 and T306

With the Enable ISDN Manual Disconnect system feature enabled, two timing associated results are possible, dependent upon the reported DISCONNECT message. A received DISCONNECT message starts timer T305 by default. A received DISCONNECT message that also has a progress indicator IE descriptor of 8, starts timer T306.

The T305 timer scenario is the default. The system reports a DISCONNECT message to the host via an ISDN Port Change of State (\$EA) report, and the RELEASE message is not triggered until an ISDN Port Control (\$49) command is received by the system from the host, or until a 4-second timer (T305) expires.

The T306 timer scenario acts in the following manner: The system reports the DISCONNECT message with a progress indicator IE descriptor of 8—in-band information or appropriate pattern is now available—to the host via an \$EA report. The RELEASE message is not triggered until a \$49 command is received by the system from the host, or until a fixed 60-second timer (T306) expires.

Timer T306 is used when the network wishes to provide in-band tones and announcements when disconnecting the call. The T306 timer is implemented on ICC T1-PRI/NTT, ICC E1-PRI/EURO, and ICC E1-PRI/TS014 protocols.

Refer to the *Cisco VCO/4K System Administrator's Guide* for further information on the Enable ISDN Manual Disconnect feature flag.

Refer to the *Cisco VCO/4K Extended Programming Reference* for further information on command and report functions.

RELEASE

The RELEASE message clears a connection. There are three conditions that can cause a RELEASE message, referred to as condition 1, condition 2, and condition 3.

- Condition 1—Causes a RELEASE message when a DISCONNECT message is received. A RELEASE message is sent to acknowledge the DISCONNECT message and clear the connection.
The system processes the RELEASE automatically. All RELEASE IEs are reported to the host and a RELEASE COMPLETE message is returned. Note that the ISDN TX token and ISDN transmit message template can also be used to transmit a RELEASE.
- Condition 2—Causes RELEASE messages when all of the following are met:
 - The Host Setup Timer is enabled.
 - The timer expires during a SETUP message.
 - A default impulse rule containing a NOHOST token is not assigned to the port.

The system sends a RELEASE message with a cause IE of Normal Clearing to the ICC ISDN span. If the state of the port on the span is Processing Received SETUP, the system sends an ISDN Port Change of State (\$EA) report to the host. The report contains an event code of Release Complete with a status code of No Error. Note that the processing of this condition sets the ICC ISDN span port to idle.

- Condition 3—Causes RELEASE messages when all of the following are met:
 - The Host Setup Timer is enabled.
 - The timer expires during a SETUP message.
 - A default impulse rule containing a GLARE token is not assigned to the port.

The system sends a RELEASE COMPLETE message with a cause IE of Preempted to the ICC ISDN span. The system also sends an ISDN Port Change Of State (\$EA) report to the host. The report contains an event code of Release Complete with a status code of Glare. Note that the processing of this condition sets the ICC ISDN span port to idle.

Refer to the “System Host Configuration” section on page 2-14 for further information on the Host Setup Timer. Refer to the “ISDN Outpulse Rule Processing” section on page 3-13 for further information on the GLARE and NOHOST tokens.

The expected response to a RELEASE is RELEASE COMPLETE.

RELEASE COMPLETE

The RELEASE COMPLETE message acknowledges receipt of a RELEASE message and is the final step in clearing a connection. No response is expected.

System processing of received RELEASE COMPLETE is automatic. All RELEASE COMPLETE IEs are reported to the host. RELEASE COMPLETE is transmitted automatically in response to a received RELEASE message.

RESTART

The RESTART message requests a restart (set to idle) for the D-channel, or individual B-channel, specified. Response to a successful request is the RESTART ACKNOWLEDGE message.

System processing of received RESTART is automatic. RESTART transmission is not supported.

For a D-channel RESTART message, a System Card Status (\$D9) report is generated indicating the ICC ISDN span has been reset. When this processing has completed, a RESTART ACKNOWLEDGE is returned.

For a B-channel RESTART message, the call on that channel is cleared and the port is set to idle. All RESTART IEs and the RESTART event are reported to the host in an ISDN Port Change of State (\$EA) report. When this processing has completed, a RESTART ACKNOWLEDGE is returned.

RESTART ACKNOWLEDGE

The RESTART ACKNOWLEDGE message indicates that a previous RESTART has been performed.

The host automatically transmits a RESTART ACKNOWLEDGE message in response to a received RESTART message, as described in the “RESTART” section on page 3-6.

ISDN D-channel Call Establishment Messages

This section describes the call establishment ISDN D-channel messages.

ALERTING

The ALERTING message indicates that called-user alerting has been initiated.

The ISDN RX token and ISDN receive message templates control how the system processes received ALERTING messages. The ISDN TX token and ISDN transmit message and supervision templates determine how ALERTING messages are transmitted.

CALL PROCEEDING

The CALL PROCEEDING message indicates that the call establishment requested by a SETUP message has been accepted and that no further call establishment messages will be accepted.

The ISDN RX token and ISDN receive message templates control how the system processes received CALL PROCEEDING messages. The ISDN TX token and ISDN transmit message and supervision templates determine how CALL PROCEEDING messages are transmitted.

CONNECT

The CONNECT message indicates the call has been accepted and should be connected.

The system automatically processes received CONNECT messages either inside or outside of rule processing. The system makes B-channel connection and returns a CONNECT ACKNOWLEDGE message. In interworking cases, the B-channel is not connected on the far end until the CONNECT has been processed. The ISDN TX token and ISDN transmit message and supervision templates determine how CONNECT messages are transmitted.

CONNECT ACKNOWLEDGE

The CONNECT ACKNOWLEDGE message indicates that the call connection has been established.

The ISDN RX token and ISDN receive message templates control how the system processes received CONNECT ACKNOWLEDGE messages. The network does not expect a response to this message, therefore, any processing is specific to the application (such as billing, etc.). CONNECT ACKNOWLEDGE is automatically transmitted in response to a received CONNECT message.

PROGRESS

The PROGRESS message provides additional information required for call establishment.

The ISDN RX token and ISDN receive message templates control how the system processes received PROGRESS messages. The ISDN TX token and ISDN transmit message and supervision templates determine how PROGRESS messages are transmitted.

SETUP

The SETUP message initiates call establishment.

When a new call originates, the system generates a D-channel SETUP message. The host constructs a message by the ISDN Port Control (\$49) command and an ISDN transmit message template.

When a system receives a SETUP message with acceptable parameters (CHAN ID, CD NUM, BEARER IEs, etc.), the system must generate a CALL PROCEEDING message and send it to the network. The system performs this action autonomously by executing a default impulse rule containing an ISDN RX and ISDN TX token. The ISDN transmit message template controls the CALL PROCEEDING message creation, and the system informs the host of the SETUP message.

The host can also generate a CALL PROCEEDING message via the \$49 command and an ISDN transmit message template, just as it does the SETUP message. In this case, the default impulse rule only specifies an ISDN RX token for the incoming SETUP message data and the host reporting requirements.

The host can reject a call establishment request; the correct message to accomplish this is a RELEASE COMPLETE with a cause IE of NETWORK CONGESTION. The host initiates the RELEASE COMPLETE message with the \$49 command.

ISDN D-channel Call Information Phase Message

This section describes the call information phase ISDN D-channel message.

User Information

The USER INFORMATION message transfers information data from one point to another.

The ISDN RX token and ISDN receive message templates control how the system processes received USER INFORMATION messages. The ISDN TX token and ISDN transmit message templates determine how USER INFORMATION messages are transmitted.

ISDN D-channel Maintenance Messages

The maintenance ISDN D-channel messages are described below.

SERVICE

The SERVICE message is supported in only the 4ESS, 5ESS, and NTI ISDN protocols. This message changes the current status of the channel to in-service, out-of-service, or maintenance. Response to a successful request is the SERVICE ACKNOWLEDGE message.

The system automatically processes received SERVICE messages. The specified channel is placed into the specified state. In the cases of out-of-service and maintenance, the channel is placed into far-end out-of-service or far-end maintenance. The system generates an ISDN Port Change of State (\$EA) report to inform the host of the change in status. Received SERVICE messages are processed only for individual channels—the system ignores SERVICE messages which use a slot map to specify multiple channels. Transmission of service messages is performed according to the ISDN protocol's specification. For the 4ESS, 5ESS, and NTI ISDN protocols, the system automatically performs SERVICE transmission as part of channel maintenance. A SERVICE message is sent once an hour for each channel in far-end out-of-service or far-end maintenance. The SERVICE message contains the requested state of the channel as maintained by the system.

SERVICE ACKNOWLEDGE

The SERVICE ACKNOWLEDGE message indicates that a received SERVICE message has been processed.

The system automatically processes received SERVICE ACKNOWLEDGE messages. No further processing is performed. SERVICE ACKNOWLEDGE transmission is automatic. This message is sent upon successful completion of a SERVICE message.

ISDN D-channel Miscellaneous Messages

This section describes the miscellaneous ISDN D-channel messages.

CONGESTION CONTROL

The CONGESTION CONTROL message indicates the establishment or termination of flow control.

The ISDN RX token and ISDN receive message templates determine how the system processes received CONGESTION CONTROL messages. The ISDN TX token and ISDN transmit message templates determine how CONGESTION CONTROL messages are transmitted.

FACILITY

The FACILITY message requests a specific facility or service. The expected response to a FACILITY message is either a FACILITY ACKNOWLEDGE message (facility request accepted) or a FACILITY REJECT message (facility request rejected).

The ISDN RX token and ISDN receive message templates determine how the system processes received FACILITY messages. The ISDN TX token and ISDN transmit message templates determine how FACILITY messages are transmitted.

FACILITY ACKNOWLEDGE

The FACILITY ACKNOWLEDGE message accepts a FACILITY request.

The ISDN RX token and ISDN receive message and supervision template processing determine how the system processes received FACILITY ACKNOWLEDGE messages. The ISDN TX token and ISDN transmit message templates determine how FACILITY ACKNOWLEDGE messages are transmitted.

FACILITY REJECT

The FACILITY REJECT message rejects a FACILITY request.

The ISDN RX token and ISDN receive message and supervision template processing determine how the system processes received FACILITY REJECT messages. The ISDN TX token and ISDN transmit message templates determine how FACILITY REJECT messages are transmitted.

NOTIFY

The NOTIFY message conveys information pertaining to a call across the interface.

The NOTIFY message is sent by the called user to the network or by the network to the calling user.

REGISTER

System processing does not currently support REGISTER.

STATUS

The STATUS message responds to a STATUS ENQUIRY message. The current call state is reported.

The system automatically processes received STATUS messages. STATUS is automatically transmitted in response to a received STATUS ENQUIRY message. No indication of this processing is provided to the host.

STATUS ENQUIRY

The STATUS ENQUIRY message requests a STATUS message from a peer Layer 3 entity. Response to a successful request is STATUS.

The system automatically processes received STATUS ENQUIRY messages. A STATUS message is transmitted; no indication of this processing is provided to the host.

Information Element Construction

Six combinations of IE storage control tokens and transmission control tokens are used to construct an information element (IE) for use in an outgoing D-channel message. Use the ISDN transmit message template to construct the IE. The combinations and their associated rules are described in Table 3-3.

Table 3-3 *Token Combinations which Build Information Elements in Outgoing D-channel Messages*

Token Combination	Associated Rule
FLD	A FLD token can be used alone if it contains an entire IE (header and data). Ensure that in an interworking scenario you do not specify an FLD number which was used for storage of non-ISDN information (such as collected DTMF digits).
I FLD DATA	Use an I FLD token, followed by one or more DATA tokens, to construct an IE. The I FLD should contain a valid IE header. One or more DATA tokens provide the additional data to complete the IE. The IE/data field for the DATA token should contain the hex information for the IE exactly as it is to be transmitted over the D-channel. The system automatically calculates the correct IE length and overwrites the IE length byte contained in the I FLD.
I FLD D FLD	Use an I FLD token, followed by one or more D FLD tokens, to construct an IE. The I FLD should contain a valid IE header. One or more D FLD tokens provide the additional data to complete the IE. The system converts the information stored in the D FLD so that it is in the proper format for transmission over the D-channel. The system automatically calculates the correct IE length and overwrites the IE length byte contained in the I FLD.

Table 3-3 Token Combinations which Build Information Elements in Outgoing D-channel Messages (continued)

Token Combination	Associated Rule
IE DATA	Use an IE token, followed by one or more DATA tokens, to construct an IE. The IE/Data field for the IE token must contain a valid IE. One or more DATA tokens provide the additional data to complete the IE. The IE/Data field for the DATA token should contain the hex information for the IE exactly as it is to be transmitted over the D-channel, excluding the IE Identifier and length bytes. The system automatically calculates the correct IE length and populates the IE length byte.
IE DATA D FLD	Use an IE token, followed by DATA and D FLD tokens, to construct an IE. The IE/data field for the IE token must contain a valid IE. One or more DATA and D FLD tokens provide the additional data to complete the IE. The IE/Data field for the DATA token should contain the hex information for the IE exactly as it is to be transmitted over the D-channel, excluding the IE Identifier and length bytes. The system converts the information stored in the D FLD so that it is in the proper format for transmission over the D-channel, excluding the length byte. The system automatically calculates the correct IE length and populates the IE length byte.
IE D FLD	Use an IE token, followed by one or more D FLD tokens, to construct an IE. The IE/Data field for the IE token must contain a valid IE. One or more D FLD tokens provide the additional data to complete the IE. The digit field(s) specified should contain the information for the IE exactly as it is to be transmitted over the D-channel, excluding the IE Identifier and length bytes. The system converts the information stored in the D FLD so that it is in the proper format for transmission over the D-channel. The system automatically calculates the correct IE length and populates the IE length byte.

Whenever a D-channel message with a channel ID IE is transmitted, the system automatically populates the channel number within the IE with the channel number being used. D FLD, DATA, and FLD tokens must include this byte.

Host-specified IE content is automatically included in transmit message construction. System processing ensures that the resultant IE ordering is correct.

ISDN Inpulse Rule Processing

For ISDN calls, the system primarily uses impulse rules to process received SETUP messages. This SETUP message processing is analogous to an incoming seizure for a non-ISDN call, and triggers default impulse rule processing, if defined. Because initial SETUP messages are received over the D-channel and there is no B-channel associated with the call at this point, the system assigns a default impulse rule to the D-channel (port 24) of the ICC ISDN span. Refer to Chapter 2, “System Administration Support,” for ICC ISDN span configuration information.

Inpulse Rule Tokens and ISDN Support

Almost all of the existing impulse rule tokens are supported for ISDN calls, except the WINK NOW token. Since there is no ISDN equivalent to a wink, this token is ignored.

The reporting control tokens—REP END, REP EACH, REP NEXT, and NO REP—in an inpulse rule govern timing of the ISDN Port Change of State (\$EA) report and the ISDN Inpulse Rule Complete (\$ED) report. The contents of the ISDN message template being processed determine the content of the reports.

Tokens which control in-band events are not applicable to an ISDN call until a B-channel has been selected. These tokens (signaling, mode, collection setup, digit collection, and some supervision control) are ignored unless an incoming B-channel has been assigned to the call.

The ANSWER token can respond to a SETUP D-channel message. Processing of this token generates a CONNECT message to the network if a B-channel has been selected. This message contains a channel ID IE if it is the initial response to the SETUP message.

ISDN messages can also be transmitted using the ISDN TX [xx] token.

WAIT TIME [xx], GOTO RULE [xx], DO ORULE [xx], and DO IRULE [xx] all retain their functionality for ISDN calls.

All collected digits are considered the equivalent of ISDN message template D FLD action tokens when two specific conditions are met. First, digit collection is in-band. Second, a B-channel has to be established for interworking scenarios in which an inpulse rule is processed for a non-ISDN port. To format these digits using a message template, use a D FLD number (1 through 4, and ANI) which corresponds to the digit field used in the original inpulse rule.

The FLD, I FLD, and D FLD action tokens used in ISDN message templates control digit storage for ISDN D-channel messages only. These tokens are discussed in the “ISDN Message Templates” section on page 2-20.

Refer to the *Cisco VCO/4K System Administrator's Guide* for further information on inpulse rule tokens.

ISDN D-channel SETUP Message Processing

The ISDN D-channel SETUP message is processed in one of two ways, depending upon whether a default inpulse rule has been defined.

ISDN D-channel SETUP Message Processing with a Default Inpulse Rule Defined

If a default inpulse rule has been defined, the following process describes the SETUP message processing:

1. The default inpulse rule is executed when the system receives an ISDN D-channel SETUP message.
2. The system sends an ISDN Inpulse Rule Complete (\$ED) report to the host—unless the rule contains a NO REP token.
3. At the end of rule processing, the Host Setup Timer is started—unless it has been disabled. Refer to the “System Host Configuration” section on page 2-14 for further information on the configuration of the Host Setup Timer.

If the host does not respond before the timer expires, one of the following occurs:

- If the inpulse rule contains a NOHOST token, the inpulse rule specified by the token is executed.
- If the inpulse rule does not contain a NOHOST token, the system sends a RELEASE message with a cause IE of Normal Clearing to the ICC ISDN span.

If the state of the port on the span is Processing Received SETUP, the system sends an ISDN Change of State (\$EA) report to the host. The report contains an event code of Release Complete with a status code of No Error.

Note that the processing of this condition sets the ICC ISDN span port to Idle.

The ISDN message templates handle the ISDN messages in the D-channel that the system does not automatically process. The ISDN RX [xx] token calls these templates.

ISDN D-channel SETUP Message Processing with No Default Impulse Rule Defined

If no default impulse rule has been defined, the following describes the SETUP message processing:

1. The system sends an ISDN Port Change of State (\$EA) report to the host. The IE content of the SETUP message is included in this report.
2. The Host Setup Timer is started—unless it has been disabled. Refer to the “System Host Configuration” section on page 2-14 for further information regarding the configuration of the Host Setup Timer.
3. If the host does not respond before the timer expires, the system sends a RELEASE message with a cause IE of Normal Clearing to the ICC ISDN span.

If the state of the port on the span is Processing Received SETUP, the system sends an ISDN Change of State (\$EA) report to the host. The report contains an event code of Release Complete with a status code of No Error.

Note that the processing of this condition sets the ICC ISDN span port to Idle.

ISDN Outpulse Rule Processing

For ISDN calls, the system uses outpulse rules in much the same way as for non-ISDN calls. An outpulse rule is started by the ISDN Port Control (\$49) command. Information can be passed into the three FLD action tokens used in ISDN message template processing.



Note

Use of the null outpulse rule is not supported for ISDN calls.

Outpulse Rule Tokens and ISDN Support

Most of the existing outpulse rule tokens are supported for ISDN calls, except the FINAL SUP [xx], SEIZE, and WAIT SUP [xx] tokens. For outgoing ISDN calls, use ISDN SUP [xx] in place of FINAL SUP [xx] and WAIT SUP [xx]. The ISDN transmit message templates provide the ISDN equivalent of a SEIZE.

Tokens which control in-band events are not applicable to an ISDN call until a B-channel has been selected. These signaling mode and digit field tokens are ignored unless an outgoing B-channel has been assigned to the call.

The outpulse rule tokens DO IRULE [xx], DO ORULE [xx], GOTO RULE [xx], REP END, TIME SUP [xx], and WAIT TIME [xx] retain their functionality for ISDN calls.

Digit fields are outpulsed with the standard digit field tokens for in-band digit outpulsing once a B-channel has been established, or for interworking scenarios in which an outpulse rule is processed for a non-ISDN port. Store digit fields collected from an ISDN B-channel as a D FLD for outpulsing. The field number (1 through 4, and ANI) corresponds to the D FLD number. Use the FLD, I FLD, and D FLD action tokens to identify the type of information contained in the field.

The system automatically translates digits, presenting them to the network in the proper format for the interface being used. For example, DTMF digits to be used in a D-channel message are converted to IA5 (ASCII coded digits) for use in the message. Digits collected over a D-channel can also be outpulsed as DTMF or as MF digits.

The ISDN SUP [xx] token allows the application designer to specify how events are handled following the transmission of a D-channel message. Event responses are defined using the ISDN supervision templates.

The ISDN TX [xx] token allows flexible construction of D-channel messages. Internal call record fields (1 through 4, and ANI) can be combined with the content of ISDN transmit message templates and host-specified information, supplied via the \$49 command, to generate messages to the network.

ISDN supervision templates and message templates are discussed in Chapter 2, “System Administration Support.” ISDN commands and reports are described in the *Cisco VCO/4K Extended Programming Reference*.

Refer to the *Cisco VCO/4K System Administrator’s Guide* for further information on outpulse rule tokens.

ISDN Glare Condition Processing

ISDN glare occurs if the system initiates an outgoing call on a B-channel at the same time the network initiates an incoming call on that same B-channel. This scenario assumes the system is processing the channel ID IE in the received SETUP message.

When processing a glare condition, the system reacts in one of two ways, depending upon whether or not a default inpulse rule has been defined.

Glare Condition Processing with a Default Inpulse Rule Defined

If the port has a default inpulse rule containing a GLARE token, the inpulse rule specified by GLARE is executed.

If the port has a default inpulse rule, but the rule does not contain a GLARE token, the system executes the same process as it does for ports with no default inpulse rule defined.

Glare Condition Processing with No Default Inpulse Rule Defined

If the port has no default inpulse rule defined, the system sends a RELEASE COMPLETE message with a cause IE of Preempted to the ICC ISDN span. The system also sends an ISDN Port Change of State (\$EA) report to the host. The report contains an event code of Release Complete, with a status code of Glare. Note that the processing of this condition sets the ICC ISDN span port to Idle.

Refer to the “D-channel Message Processing” section on page 3-2 for more information on channel ID IE processing.

ISDN PRI Implementation Strategies and Considerations

The following guidelines are intended to assist application designers develop ISDN applications that make the most efficient use of system processing. These are guidelines only, and should not preclude other application design approaches. In some cases, more efficient ISDN processing can mean less efficient host link processing. These guidelines are presented to help you understand how the system processes ISDN calls. The four guidelines are described below.

Use ISDN Message Templates to Specify Information Elements

Specifying IEs in the ISDN Port Control (\$49) command requires the system to copy the information into a buffer for use in an outpulse rule. Using an ISDN transmit message template eliminates the need to copy to the buffer.

Use ISDN Message Templates to Process Channel ID Information Elements

Allowing the system to assign the B-channel to a call simplifies the internal processing required to track the call. Use PROCESS CHAN ID in response to the SETUP message whenever possible.

Use the REP EACH Token in Inpulse Rules

When the system reports each D-channel message as it is received, the internal processing required to track and store these messages is simplified.

Specify Call ID Only If No B-channel Has Been Assigned to the Call

Specifying a B-channel by call ID in an ISDN Port Control (\$49) command requires more internal processing than setting the call ID bytes to \$00 00 and supplying the B-channel address. Use call ID only if no B-channel has been assigned to the call.



Call Examples

This chapter presents examples that illustrate the interaction of template, rule, command, and report processing for ISDN calls. These examples consist of the following components:

- Description of the call scenario
- Information flow between the connected equipment (user or network) and the system
- Information flow between the host and the system

For these examples, it is assumed that there are two ICC ISDN spans in the system—one with a D-channel at port address 00 00 00 1F (for incoming calls), and one at port address 00 00 00 37 (for outgoing calls). The port addresses of B-channels for incoming calls are between 00 00 00 08 and 00 00 00 1E, inclusive. The port addresses of B-channels for outgoing calls are between 0 00 00 20 and 00 00 00 36, inclusive. Additional system configuration information is shown in Figure 4-1 through Figure 4-7, and includes the following information:

- ISDN message template summary listings
- ISDN message templates listings
- ISDN supervision templates listings
- Impulse rules table listings
- Outpulse rules table listings

These listings are shown as they would appear after entry into the system database via the system administration utilities. For more information on system administration, refer to Chapter 2, “System Administration Support,” of this document, and the *Cisco VCO/4K System Administrator's Guide*.

Each example begins with a brief introductory text explanation. Each figure following the introductory text shows system processing and information flow in two directions—between the system and host, and the system and connected equipment (user or network)—via the ICC ISDN span. Arrows under the message data (bytes) show the direction of information flow. Each area of the message data is labeled.

Figure 4-1 ISDN Message Template Summary Screen

I S D N M E S S A G E T E M P L A T E S U M M A R Y											
NO	MESSAGE	R/T	DSP	NO	MESSAGE	R/T	DSP	NO	MESSAGE	R/T	DSP
1	SETUP	R	---	17	-----	---	---	33	-----	---	---
2	SETUP	R	-	18	-----	-	-	34	-----	-	-
3	SETUP	R	-	19	-----	-	-	35	-----	-	-
4	PROCEED	T	-	20	-----	-	-	36	-----	-	-
5	SETUP	T	-	21	-----	-	-	37	-----	-	-
6	ALERTING	R	-	22	-----	-	-	38	-----	-	-
7	CONNECT	R	-	23	-----	-	-	39	-----	-	-
8	SETUP	T	-	24	-----	-	-	40	-----	-	-
9	SETUP	R	-	25	-----	-	-	41	-----	-	-
10	-----	-	-	26	-----	-	-	42	-----	-	-
11	-----	-	-	27	-----	-	-	43	-----	-	-
12	-----	-	-	28	-----	-	-	44	-----	-	-
13	-----	-	-	29	-----	-	-	45	-----	-	-
14	-----	-	-	30	-----	-	-	46	-----	-	-
15	-----	-	-	31	-----	-	-	47	-----	-	-
16	-----	-	-	32	-----	-	-	48	-----	-	-

50551

Figure 4-2 ISDN Message Templates Screen (Display of Templates 1 to 4)

I S D N M E S S A G E T E M P L A T E S								
Tmpl	Message	R/T	Tmpl	Message	R/T	Tmpl	Message	R/T
1	SETUP	R	2	SETUP	R	3	SETUP	R
4	PROCEED	T						
REP ALL	-----		REP	CHAN ID		REP	CHAN ID	IE
-----	-----		FLD 1	CP NUM		PROCESS	CHAN ID	DATA
-----	-----		REP	CD NUM		D FLD 1	CD NUM	A98300
-----	-----		-----	-----		REP	CD NUM	-----
-----	-----		-----	-----		I FLD 2	CP NUM	-----
-----	-----		-----	-----		FLD 3	BEARER	-----
-----	-----		-----	-----		D FLD 4	CP NUM	-----
-----	-----		-----	-----		-----	-----	-----
-----	-----		-----	-----		-----	-----	-----
-----	-----		-----	-----		-----	-----	-----
-----	-----		-----	-----		-----	-----	-----
-----	-----		-----	-----		-----	-----	-----
-----	-----		-----	-----		-----	-----	-----
-----	-----		-----	-----		-----	-----	-----
-----	-----		-----	-----		-----	-----	-----
-----	-----		-----	-----		-----	-----	-----
-----	-----		-----	-----		-----	-----	-----
-----	-----		-----	-----		-----	-----	-----
-----	-----		-----	-----		-----	-----	-----
-----	-----		-----	-----		-----	-----	-----
-----	-----		-----	-----		-----	-----	-----
-----	-----		-----	-----		-----	-----	-----
-----	-----		-----	-----		-----	-----	-----

50552

Figure 4-3 ISDN Message Templates Screen (Display of Templates 5 to 8)

I S D N M E S S A G E T E M P L A T E S							
Tmpl	Message	R/T	Tmpl	Message	R/T	Tmpl	Message
5	SETUP	T	6	ALERTING	R	7	CONNECT R
FLD 3	_____		REP	CHAN ID	_____	_____	IE
IE	CHAN ID	_____	_____	_____	_____	_____	CHAN ID
DATA	A98300	_____	_____	_____	_____	_____	DATA
_____	_____	_____	_____	_____	_____	_____	A98300
_____	_____	_____	_____	_____	_____	_____	FLD 3
_____	_____	_____	_____	_____	_____	_____	IE
_____	_____	_____	_____	_____	_____	_____	CP NUM
_____	_____	_____	_____	_____	_____	_____	DATA
_____	_____	_____	_____	_____	_____	_____	A180
_____	_____	_____	_____	_____	_____	_____	D FLD 4
_____	_____	_____	_____	_____	_____	_____	_____
_____	_____	_____	_____	_____	_____	_____	_____
_____	_____	_____	_____	_____	_____	_____	_____
_____	_____	_____	_____	_____	_____	_____	_____
_____	_____	_____	_____	_____	_____	_____	_____
_____	_____	_____	_____	_____	_____	_____	_____
_____	_____	_____	_____	_____	_____	_____	_____
_____	_____	_____	_____	_____	_____	_____	_____

50556

Figure 4-4 ISDN Message Templates Screen (Display of Template 9)

I S D N M E S S A G E T E M P L A T E S							
Tmpl	Message	R/T	Tmpl	Message	R/T	Tmpl	Message
9	SETUP	R					
REP ALL	_____		_____	_____	_____	_____	_____
PROCESS	CHAN ID	_____	_____	_____	_____	_____	_____
_____	_____	_____	_____	_____	_____	_____	_____
_____	_____	_____	_____	_____	_____	_____	_____
_____	_____	_____	_____	_____	_____	_____	_____
_____	_____	_____	_____	_____	_____	_____	_____
_____	_____	_____	_____	_____	_____	_____	_____
_____	_____	_____	_____	_____	_____	_____	_____
_____	_____	_____	_____	_____	_____	_____	_____
_____	_____	_____	_____	_____	_____	_____	_____
_____	_____	_____	_____	_____	_____	_____	_____
_____	_____	_____	_____	_____	_____	_____	_____
_____	_____	_____	_____	_____	_____	_____	_____
_____	_____	_____	_____	_____	_____	_____	_____
_____	_____	_____	_____	_____	_____	_____	_____

37513

Figure 4-5 ISDN Supervision Templates Screen

I S D N S U P E R V I S I O N T E M P L A T E S								
	1	2	3	4	5	6	7	8
TIME	_____	_____	_____	_____	_____	_____	_____	_____
ALERTING	REP _____	_____	_____	_____	_____	_____	_____	_____
CONNECT	ANSREP _____	_____	_____	_____	_____	_____	_____	_____
PROGRESS	_____	_____	_____	_____	_____	_____	_____	_____
CALLPROC	_____	_____	_____	_____	_____	_____	_____	_____
CONN ACK	_____	_____	_____	_____	_____	_____	_____	_____
USERINFO	_____	_____	_____	_____	_____	_____	_____	_____
CONGEST	_____	_____	_____	_____	_____	_____	_____	_____
FACILACK	_____	_____	_____	_____	_____	_____	_____	_____
FACILREJ	_____	_____	_____	_____	_____	_____	_____	_____

50553

Figure 4-6 Inpulse Rules Table Screen (Display of Rules 1 to 5)

I N P U L S E R U L E S T A B L E									
RULE # 1		RULE # 2		RULE # 3		RULE # 4		RULE # 5	
ISDN RX	1	ISDN RX	2	ISDN RX	3	REP EACH	_____	NO REP	_____
_____	_____	_____	_____	ISDN TX	4	ISDN RX	9	REP NEXT	_____
_____	_____	_____	_____	_____	_____	_____	_____	ISDN RX	9
_____	_____	_____	_____	_____	_____	_____	_____	_____	_____
_____	_____	_____	_____	_____	_____	_____	_____	_____	_____
_____	_____	_____	_____	_____	_____	_____	_____	_____	_____
_____	_____	_____	_____	_____	_____	_____	_____	_____	_____
_____	_____	_____	_____	_____	_____	_____	_____	_____	_____
_____	_____	_____	_____	_____	_____	_____	_____	_____	_____
_____	_____	_____	_____	_____	_____	_____	_____	_____	_____
_____	_____	_____	_____	_____	_____	_____	_____	_____	_____
_____	_____	_____	_____	_____	_____	_____	_____	_____	_____
_____	_____	_____	_____	_____	_____	_____	_____	_____	_____
_____	_____	_____	_____	_____	_____	_____	_____	_____	_____

50562

Figure 4-7 Outputse Rules Table Screen (Display of Rules 1 to 5)

O U T P U L S E R U L E S T A B L E				
RULE # 1	RULE # 2	RULE # 3	RULE # 4	Start Rule # 1 RULE # 5
ISDN TX 5	ISDN RX 6	_____	_____	_____
_____	ISDN RX 7	_____	_____	_____
_____	ISDN TX 8	_____	_____	_____
_____	ISDN SUP 1	_____	_____	_____
_____	FINAL SUP	_____	_____	_____
_____	_____	_____	_____	_____
_____	_____	_____	_____	_____
_____	_____	_____	_____	_____
_____	_____	_____	_____	_____
_____	_____	_____	_____	_____
_____	_____	_____	_____	_____
_____	_____	_____	_____	_____
_____	_____	_____	_____	_____
_____	_____	_____	_____	_____
_____	_____	_____	_____	_____
_____	_____	_____	_____	_____
_____	_____	_____	_____	_____
_____	_____	_____	_____	_____
_____	_____	_____	_____	_____
_____	_____	_____	_____	_____

50657

Example 1—Response to Incoming SETUP Message

Example 1 shows a simple scenario in which the system receives an incoming SETUP message over the D-channel at port address 00 00 00 1F. The processing flow for this example is shown in Figure 4-8. It is assumed that the default impulse rule has been defined as impulse rule #1.

At the end of this scenario, the incoming call is in setup state awaiting further host action. If no command is received within the time frame specified by the Host Setup Timer, the call is torn down and the system issues a RELEASE COMPLETE message to the network over the D-channel. Refer to “System Host Configuration” section on page 2-14 for further information on the Host Setup Timer.

Figure 4-8 Processing Flow for Example 1

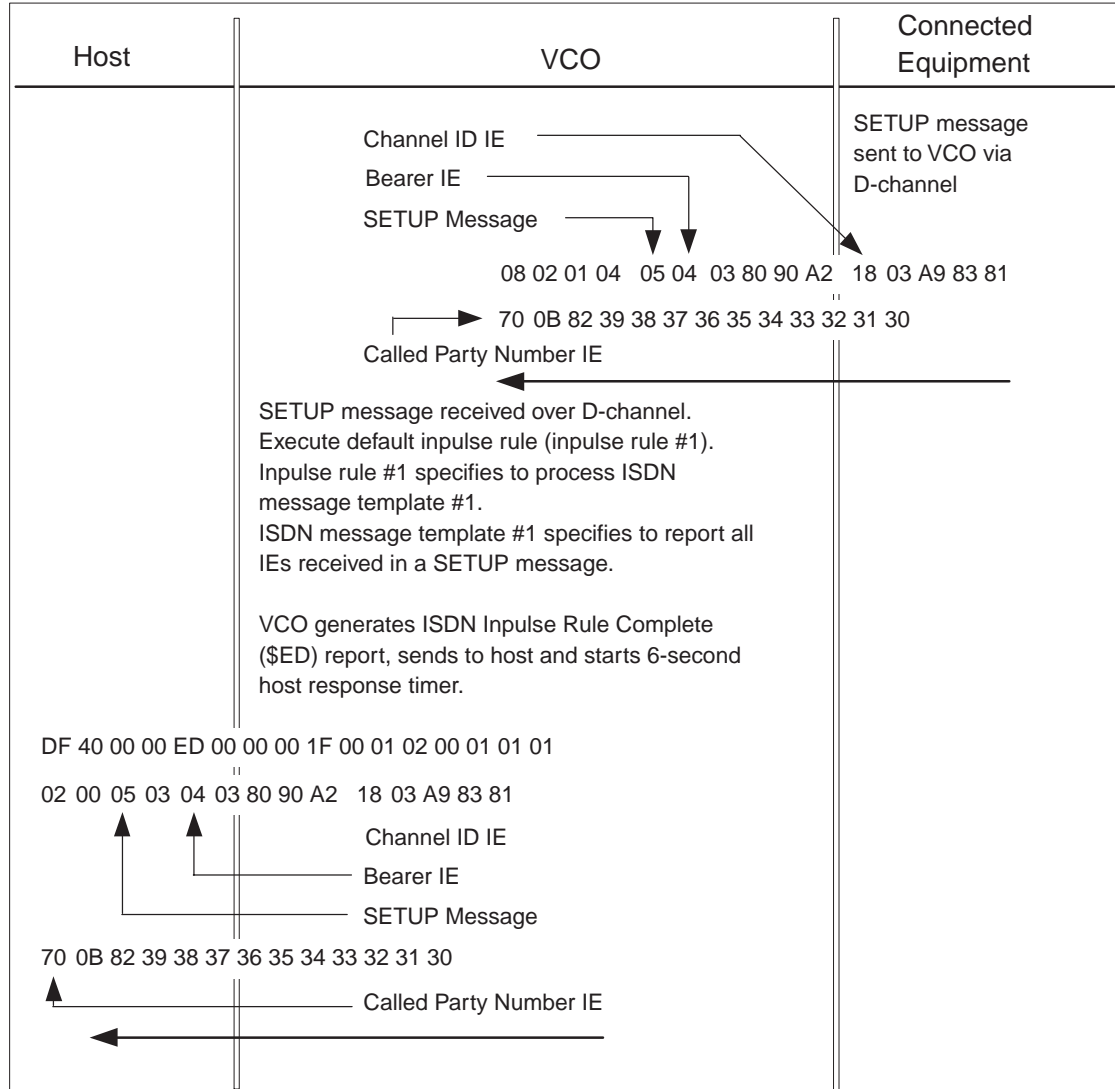

50566

Example 2—Selective Reporting of Information Elements and Digit Storage

Example 2 provides a variation on system processing of the SETUP message. Again, the system receives an incoming SETUP message over the D-channel at port address 00 00 00 1F. The processing flow for this example is shown in Figure 4-9. This time, only the channel ID and called party number are reported to the host. The entire calling party IE is stored in field 1 for later use. This time the default inpulse rule has been defined as inpulse rule #2.

Selective reporting of IEs allows the application designer to use the system to filter D-channel messages for the host. Storage of IEs in system digit fields facilitates the construction of outgoing D-channel messages; this use of digit fields is shown in Examples 6 and 7.

As in the previous scenario, the incoming call is placed into setup state awaiting further host action. If no command is received within six seconds, the call is torn down and the system issues a RELEASE COMPLETE message to the network over the D-channel.

Figure 4-9 Processing Flow for Example 2

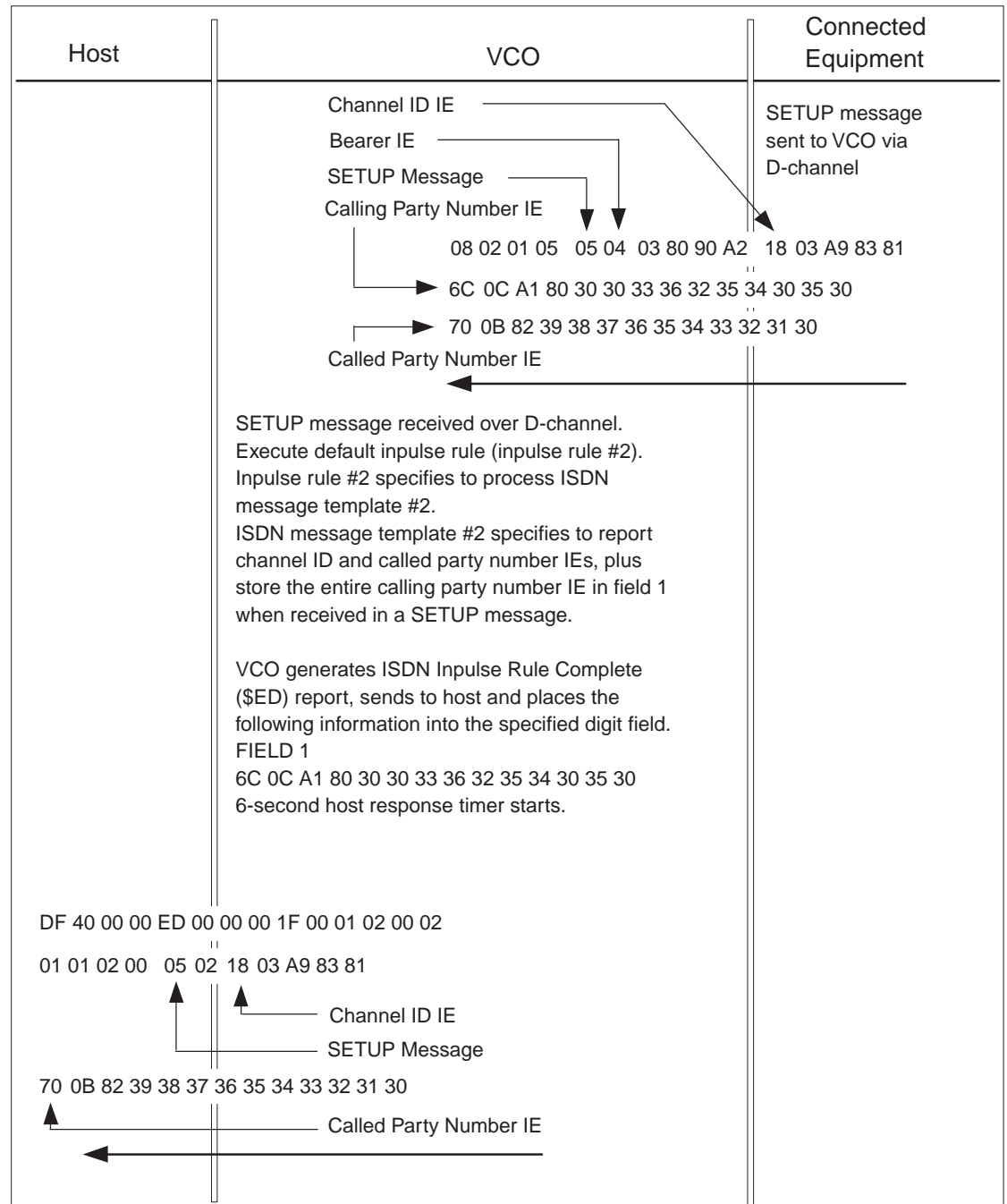

50567

Example 3—Channel ID Processing, Selective IE Storage, and D-Channel Message Construction

Example 3 shows another variation on system processing of the SETUP message. As in the previous examples, the system receives an incoming SETUP message over the D-channel at port address 00 00 00 1F. Processing flow for this example is shown in Figure 4-10 and Figure 4-11. The default impulse rule has been defined as impulse rule #3.

This example continues by using a second ISDN message template to construct and transmit a D-channel message without host intervention. Using the information gathered from the SETUP message, the system constructs a CALL PROCEEDING message and transmits it back to the network before reporting to the host.

As in the previous scenario, the incoming call is placed into setup state awaiting further host action. If no command is received within six seconds, the call is torn down and the system issues a RELEASE COMPLETE message to the network over the D-channel.

Figure 4-10 Processing Flow for Example 3 (Part 1 of 2)

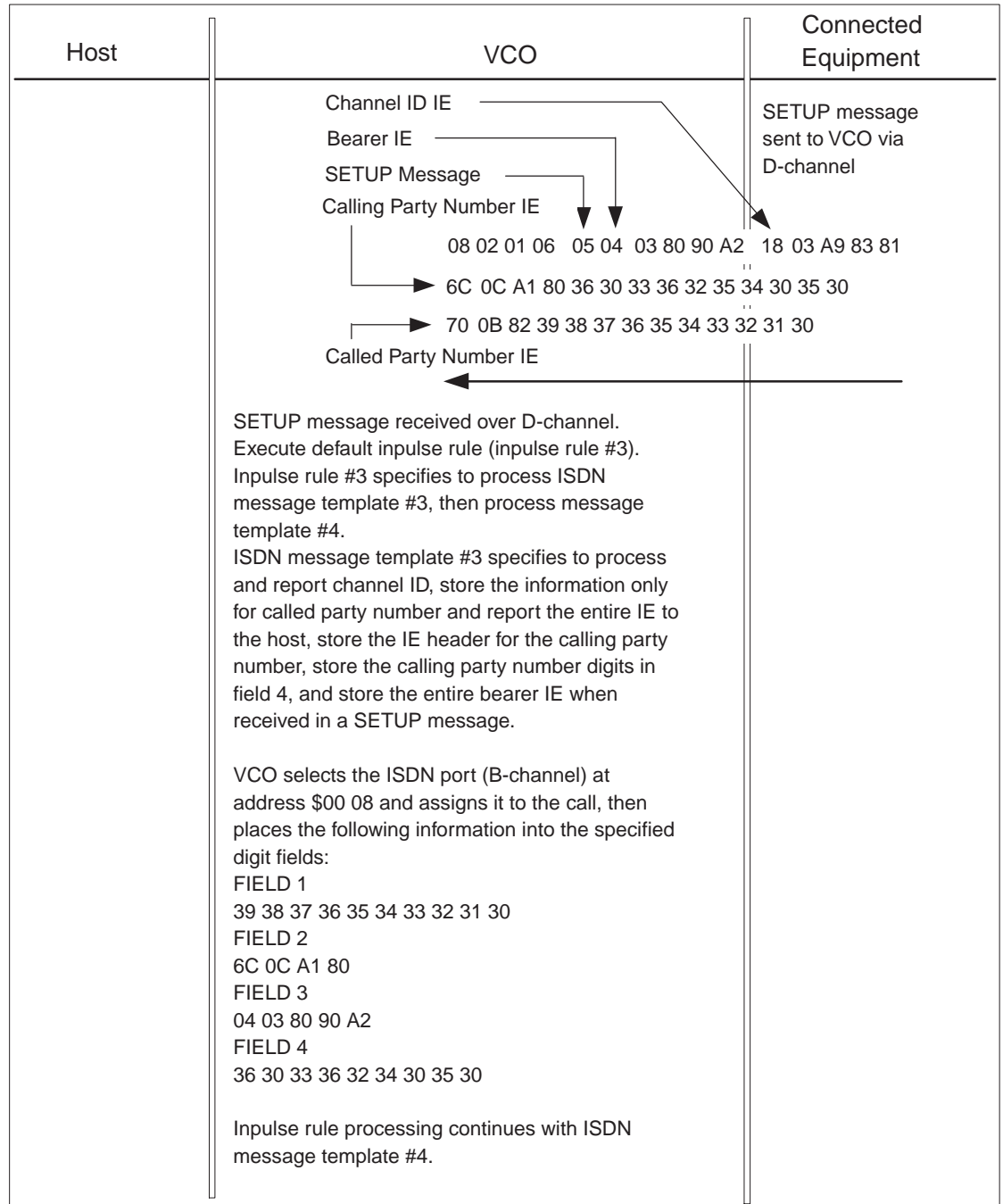

50568

Figure 4-11 Processing Flow for Example 3 (Part 2 of 2)

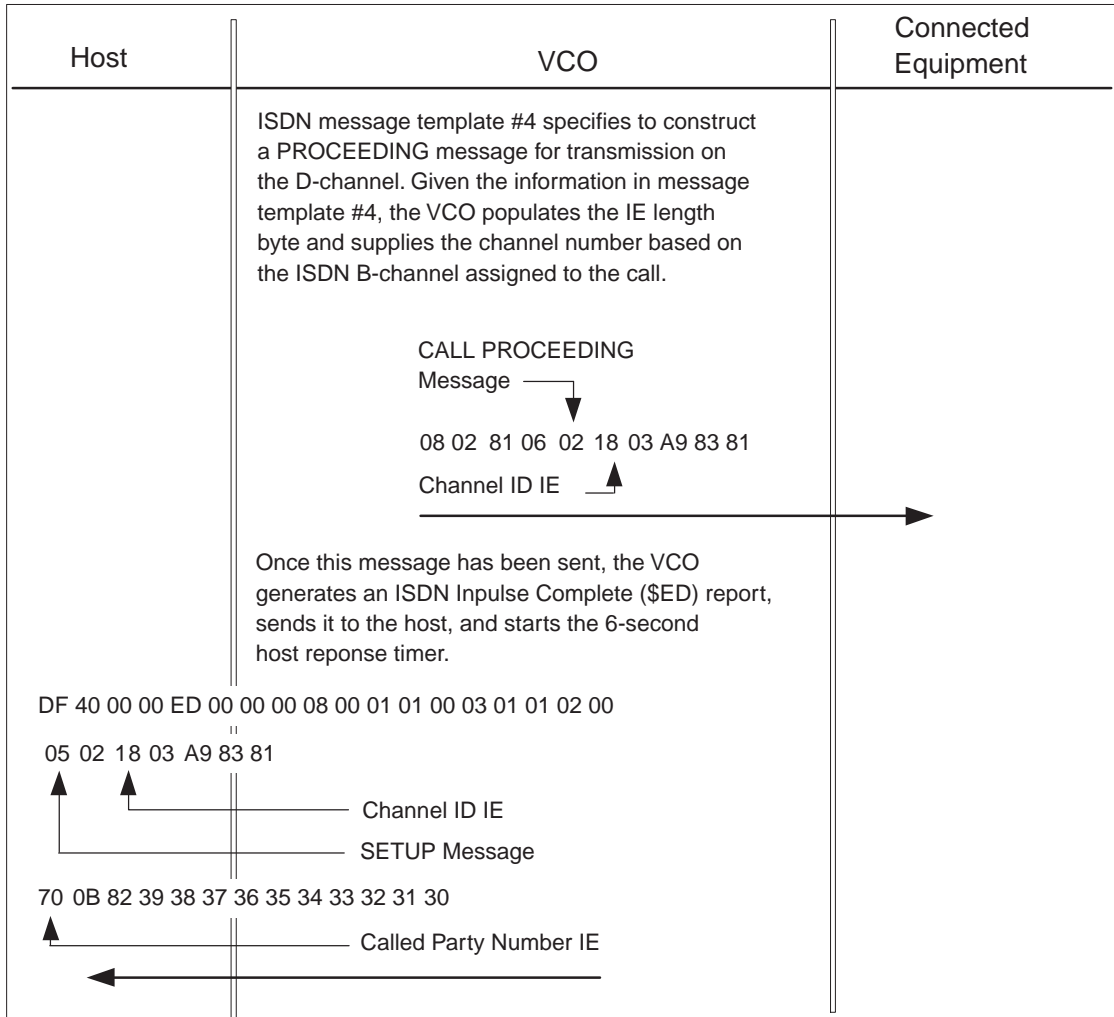

50569

Example 4—Change of State Reporting Before End of Rule

Example 4 shows the interaction between the impulse rule reporting control group of tokens and the ISDN message template reporting control group of tokens. The processing flow for this example is shown in Figure 4-12. The default impulse rule has been defined as impulse rule #4.

The REP EACH token in the impulse rule generates an ISDN Port Change of State (\$ED) report prior to the end of rule reporting. This means two reports are sent to the host instead of the one report in the previous examples. An application can make use of this intermediate reporting to begin processing for a scenario before completion of the rule.

As in all previous scenarios, the incoming call is placed into setup state awaiting further host action. If no command is received within six seconds, the call is torn down and the system issues a RELEASE COMPLETE message to the network over the D-channel.

Figure 4-12 Processing Flow for Example 4

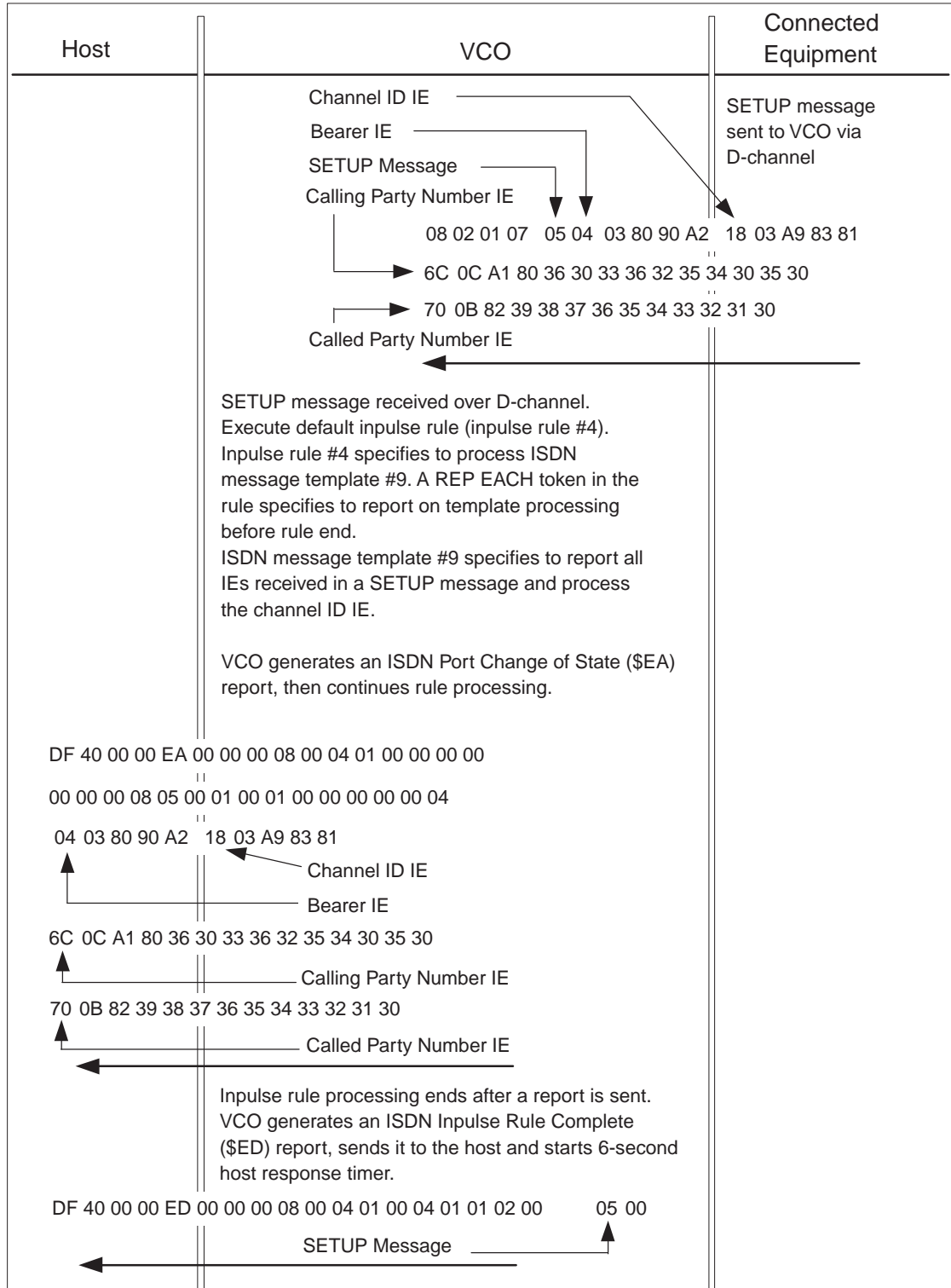

Example 5—Change of State Reporting with End of Rule Reporting Suppressed

Example 5, similar to example 4, shows the interaction between the impulse rule reporting control group of tokens and the ISDN message template reporting control group of tokens. The processing flow for this example is shown in Figure 4-13. The default impulse rule has been defined as impulse rule #5.

This time, a NO REP token suppresses end of rule processing. A REP NEXT is used just before the ISDN RX [xx] token to cause reporting of IEs in an ISDN Port Change of State (\$EA) report.

As in all previous scenarios, the incoming call is placed into setup state awaiting further host action. If no command is received within six seconds, the call is torn down and the system issues a RELEASE COMPLETE message to the network over the D-channel.

Figure 4-13 Processing Flow for Example 5

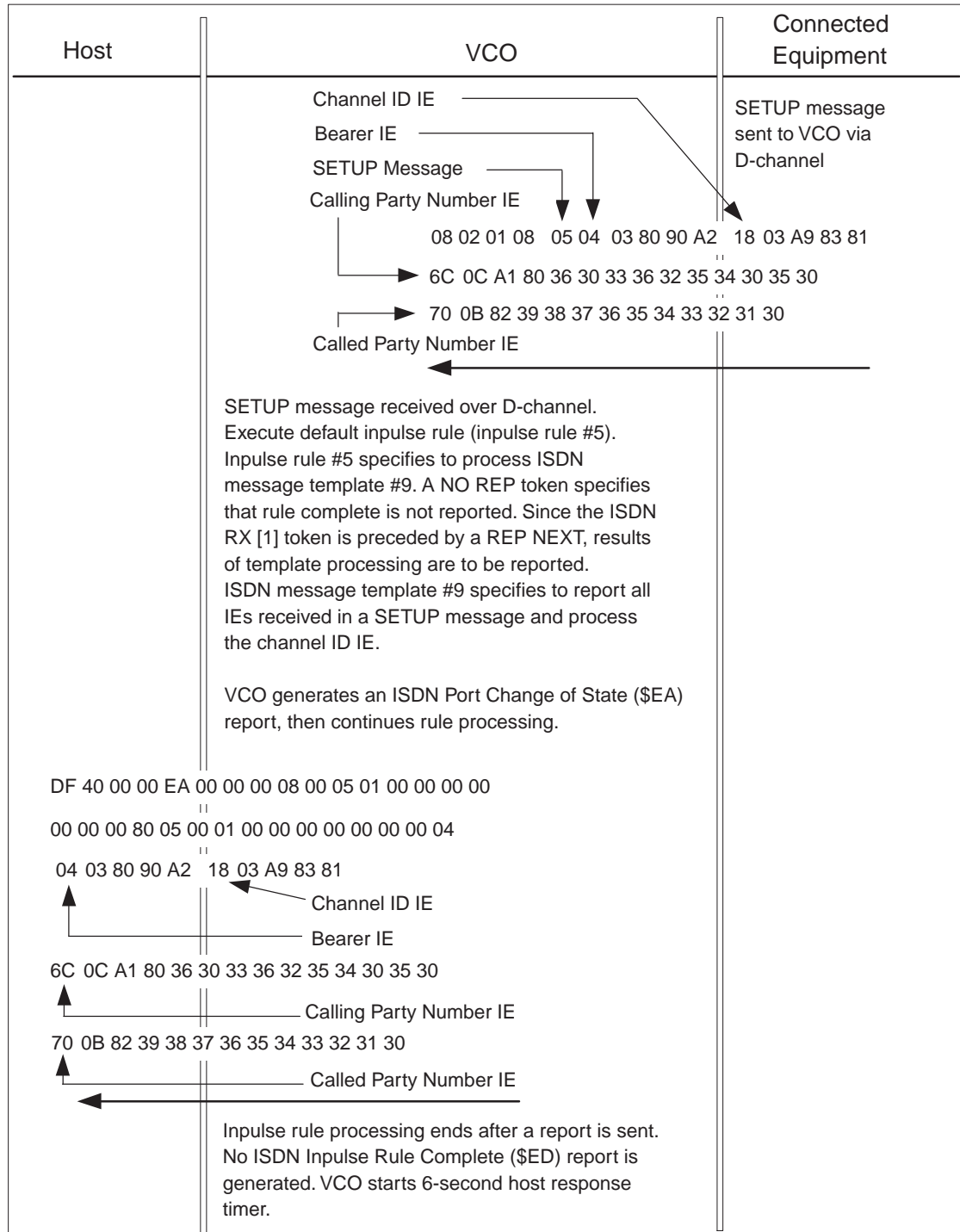

50571

Example 6—Processing of ISDN Port Control (\$49) Command

Example 6 builds upon example 3 by assuming the incoming call is in a setup state. The host issues an ISDN Port Control (\$49) command, using the incoming B-channel as the controlling port. The system makes use of the bearer IE stored in field 3, and additional IE information included in the host command, to construct a SETUP message for transmission to the network. In this case, the outgoing SETUP is sent over the D-channel at address 00 00 00 37. Byte offsets 0 through 26 are returned to the host to provide the associated (outgoing) B-channel address and call ID.

At the end of this example, the incoming call is in a CP_WANS (waiting for answer) state. The outgoing call is in CP_WTFSUP (waiting for final supervision) state, waiting for a response to the call establishment request. Further host interaction and connect processing is necessary before the call is considered completed.

Following transmission of the SETUP message, the network responds with a CALL PROCEEDING message. When the system receives the CALL PROCEEDING message, it generates an ISDN Port Change of State (\$EA) report. The processing flow for this example is illustrated in Figure 4-14 and Figure 4-15.

Figure 4-14 Processing Flow for Example 6 (Part 1 of 2)

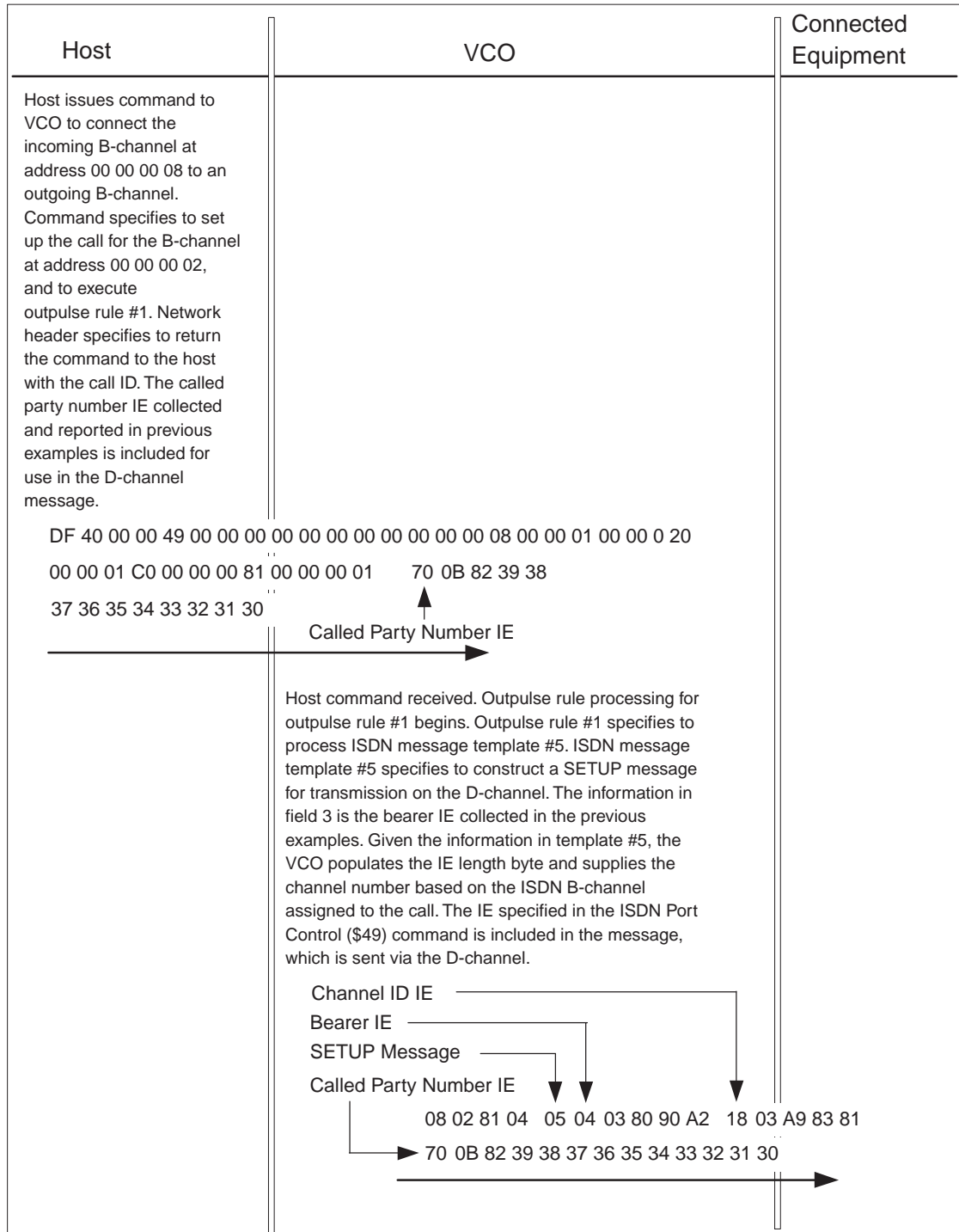

50572

Figure 4-15 Processing Flow for Example 6 (Part 2 of 2)

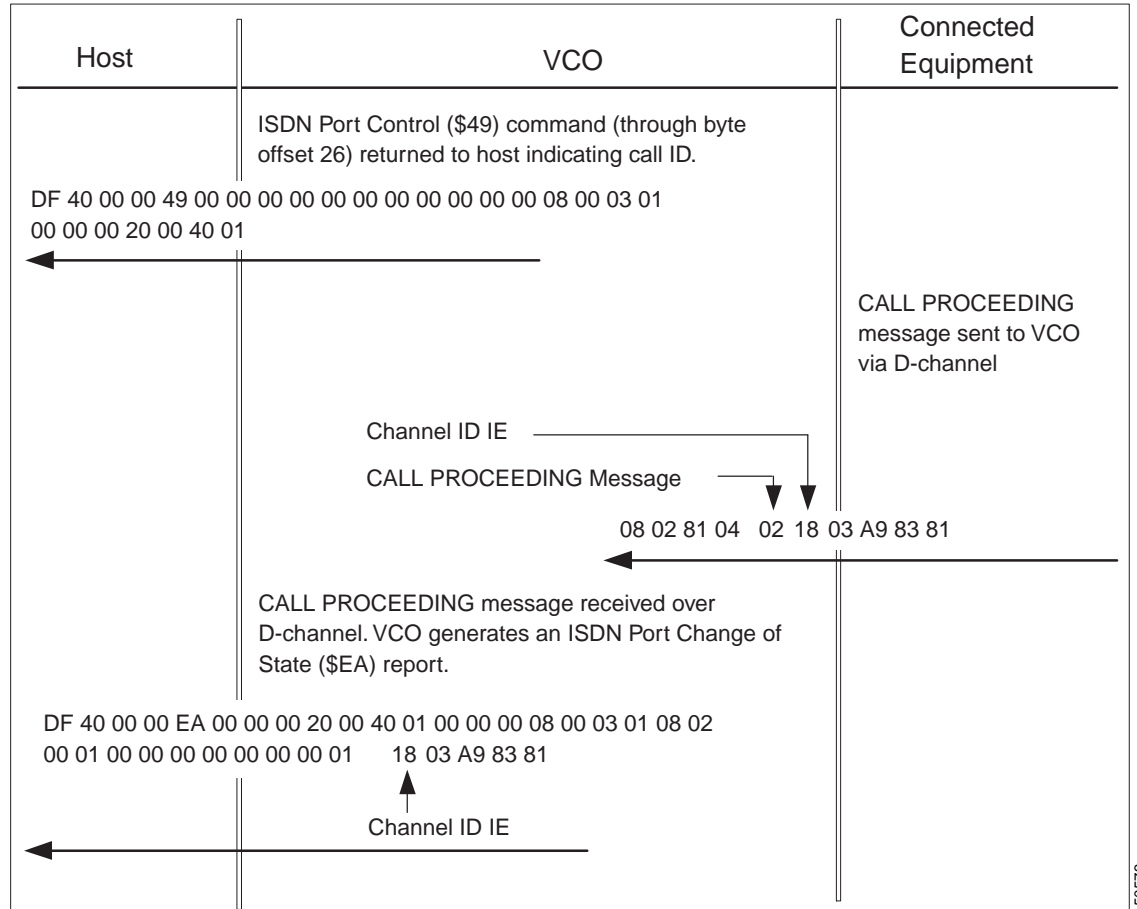

50573

Example 7—Stable Call Established Via Host Command and Template Processing

Example 7, similar to example 6, builds upon the previous examples by assuming the incoming call is in a setup state. The host issues an ISDN Port Control (\$49) command, using the incoming B-channel as the controlling port. The system makes use of the calling party number stored in field 2, the bearer IE stored in field 3, and additional IE information included in the host command, to construct a SETUP message for transmission to the network. The outgoing SETUP is sent over the D-channel at address 00 00 00 37. Byte offsets 0 through 26 are returned to the host to provide the associated (outgoing) B-channel address and call ID.

Additional ISDN message templates are processed to handle received ALERTING and CONNECT D-channel messages. An ISDN supervision template determines when to consider the call answered and stable. Answer, in the form of a CONNECT message, is propagated to the incoming D-channel to complete the call scenario. At the end of this example, a stable ISDN-to-ISDN B-channel call exists. The processing flow for this example is shown in Figure 4-16, Figure 4-17, and Figure 4-18.

Figure 4-16 Processing Flow for Example 7 (Part 1 of 3)

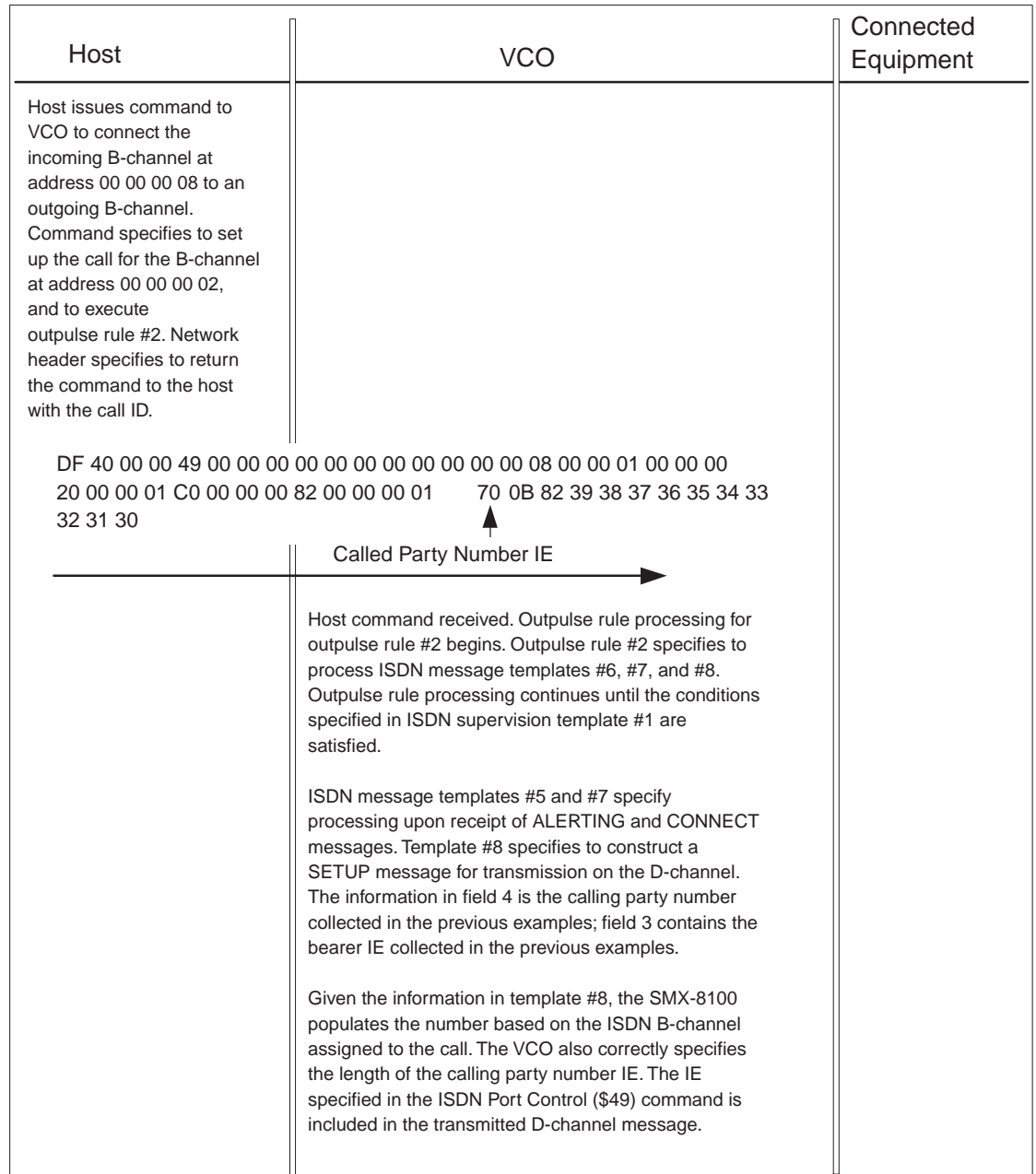

50574

Figure 4-17 Processing Flow for Example 7 (Part 2 of 3)

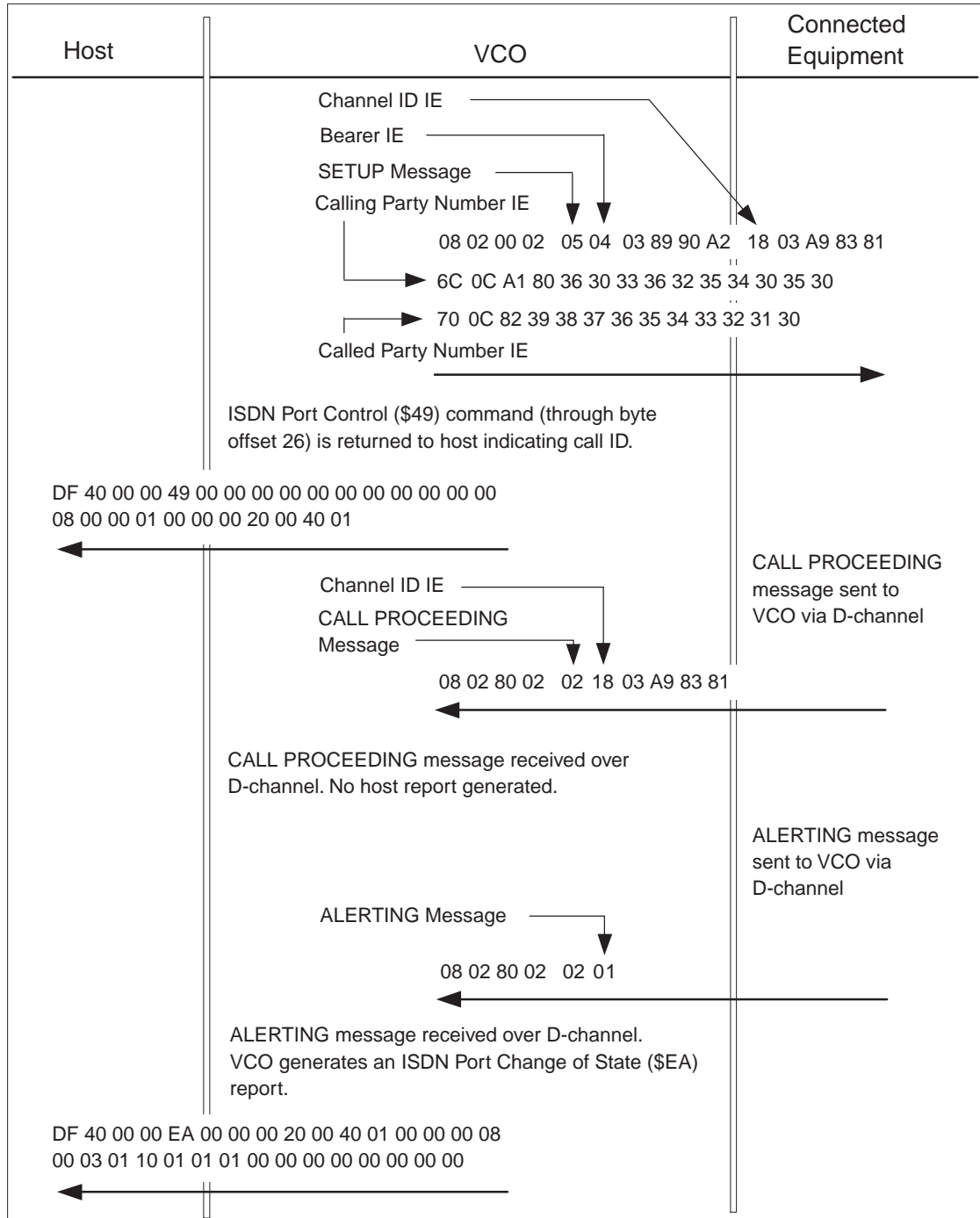

50575

Figure 4-18 Processing Flow for Example 7 (Part 3 of 3)

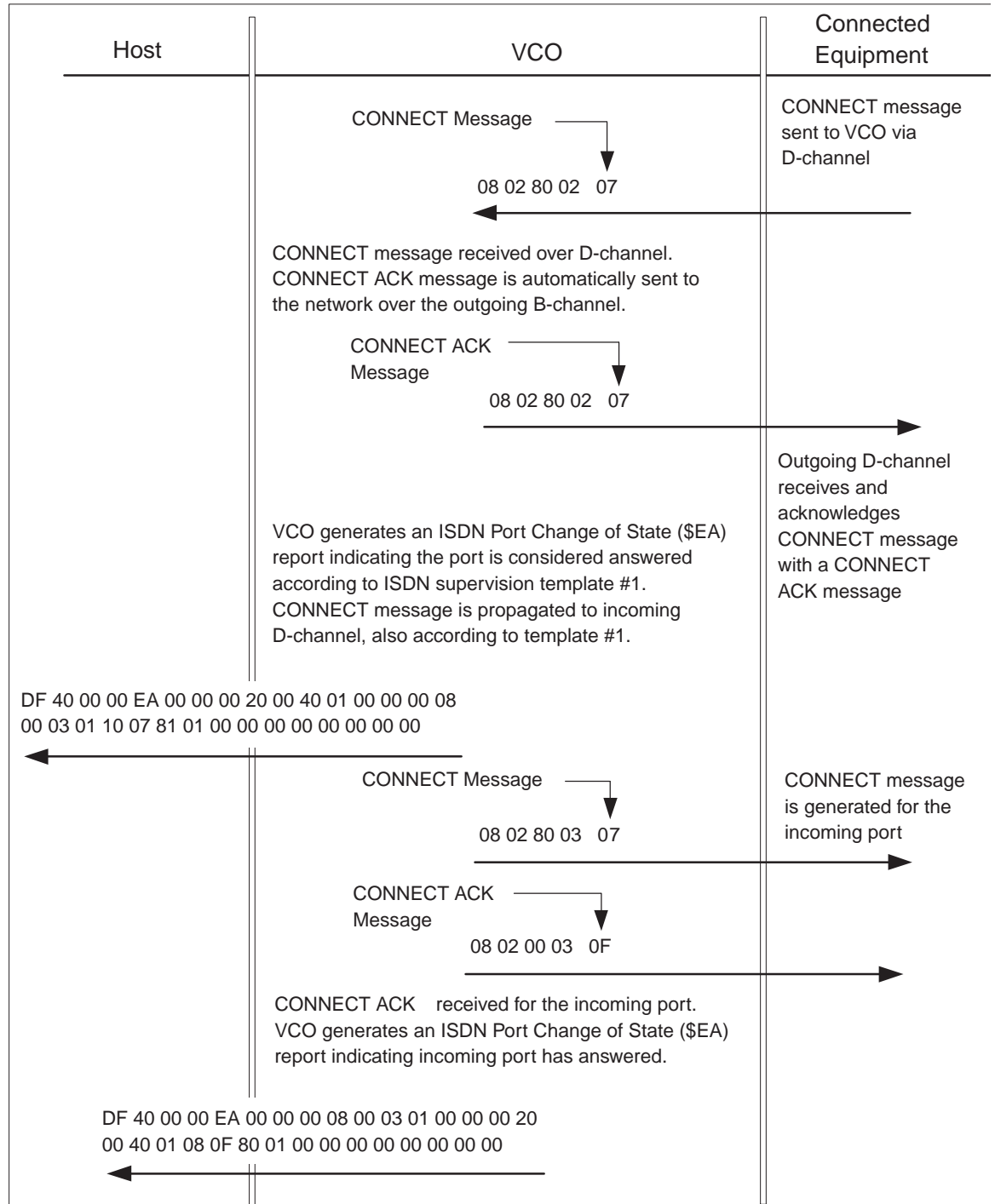

Example 8—Automatic Call Disconnect

Example 8 shows how the call established in example 7 is torn down when the outgoing B-channel is released. In this example, the Enable ISDN Manual Disconnect feature flag is set to N. Therefore, the host is not involved in processing the DISCONNECT. The system responds to the received DISCONNECT message for the outgoing B-channel by returning a RELEASE message, then setting the B-channel to an idle state. The network finishes the processing by returning a RELEASE COMPLETE message for the outgoing B-channel. An ISDN Port Change of State (\$EA) report is sent to the host, indicating the outgoing B-channel has been idled and is free for another call.

In response to the outgoing disconnect, the system sends a DISCONNECT message for the incoming B-channel. The response from the network is a RELEASE message. The system completes the processing by returning a RELEASE COMPLETE message, idling the incoming B-channel, and generating an ISDN Port Change of State (\$EA) report to the host that indicates the incoming B-channel has been idled and is free for another call. The processing flow for this example is illustrated in Figure 4-19 and Figure 4-20.

Figure 4-19 Processing Flow for Example 8 (Part 1 of 2)

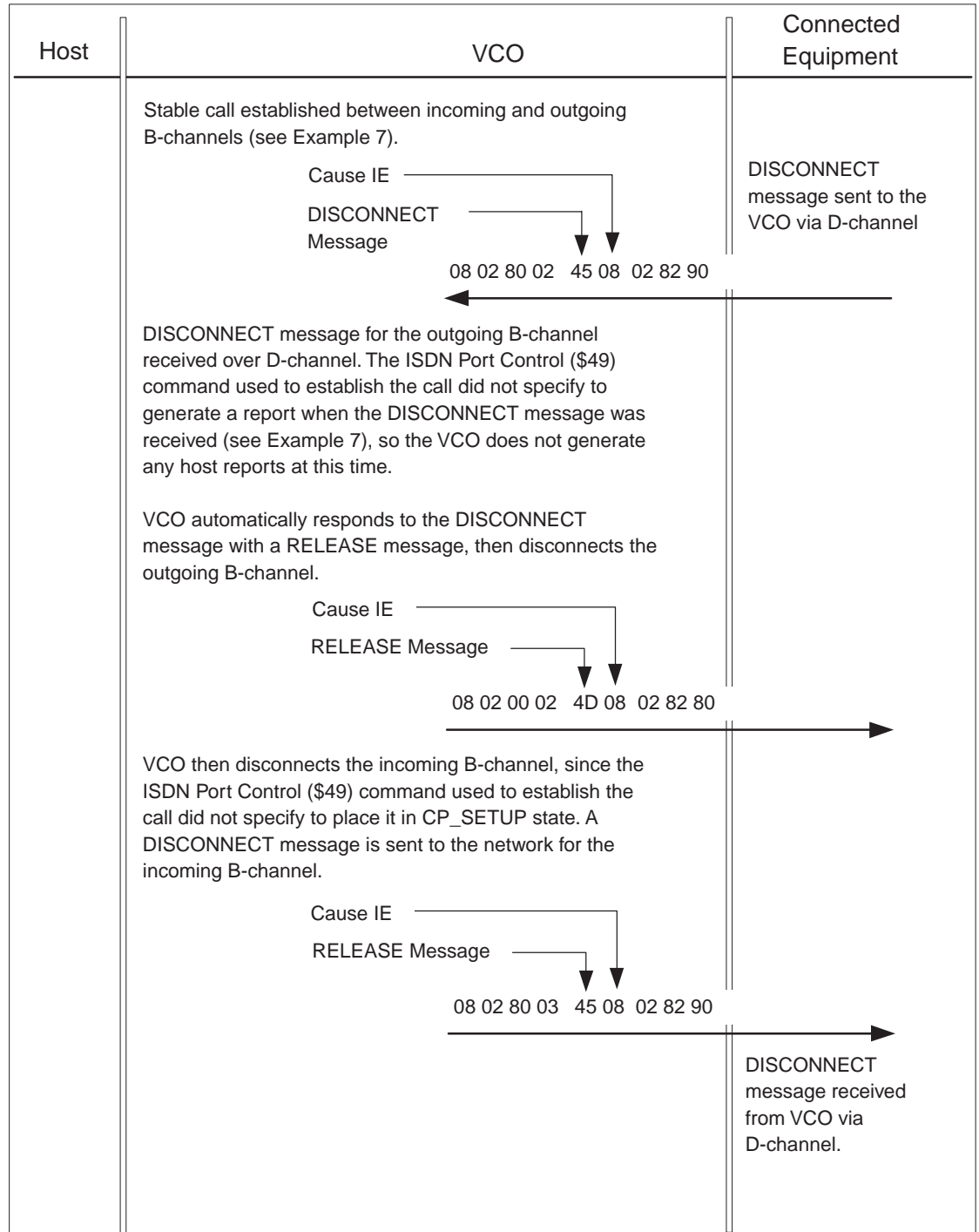

50577

Figure 4-20 Processing Flow for Example 8 (Part 2 of 2)

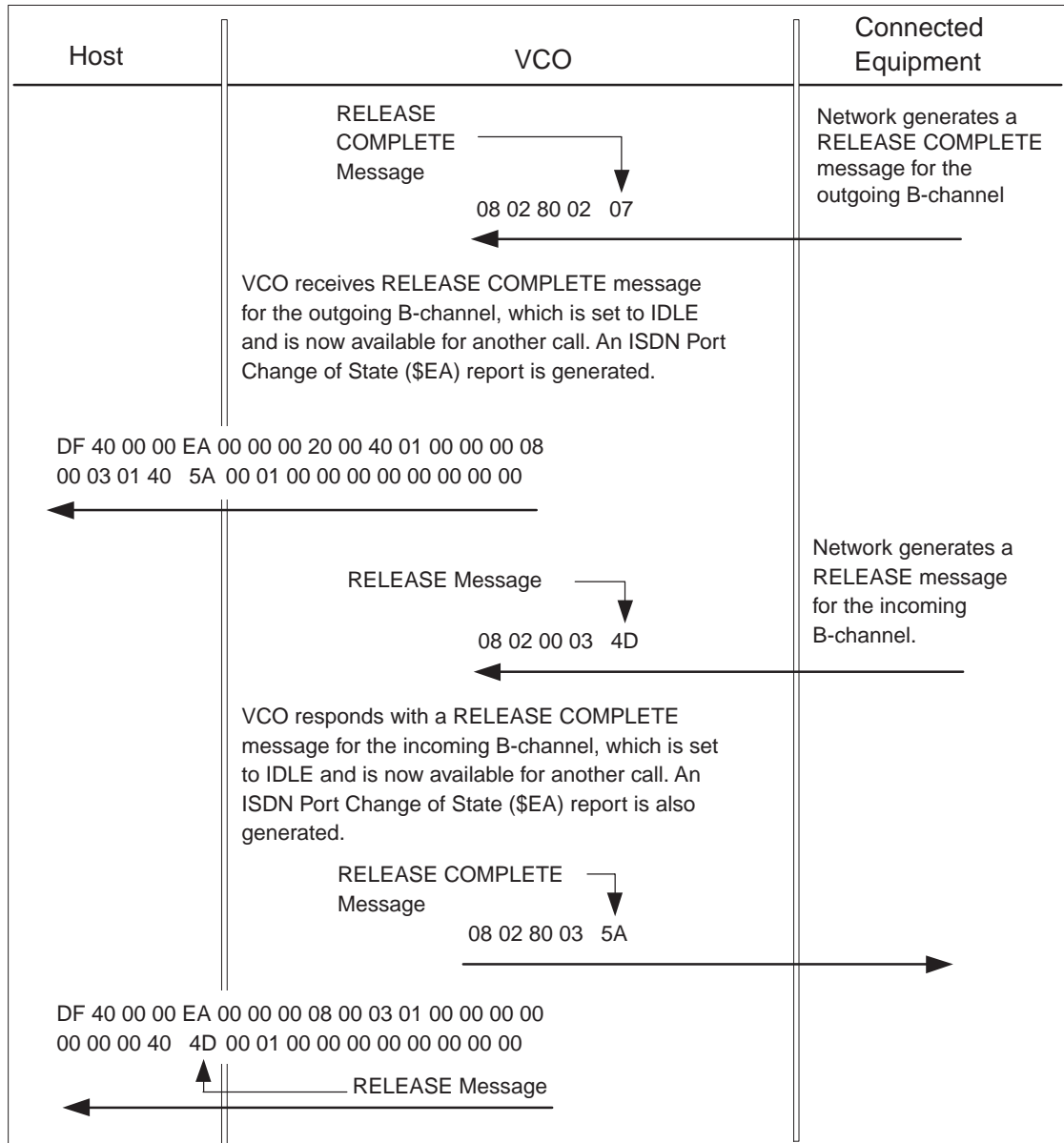

50578

Example 9—Manual Call Disconnect

Example 9 shows how the call established in example 7 is processed when the Enable ISDN Manual Disconnect feature flag is set to Y. In this example, the D and R bits of byte offset 29 (disconnect control) of the ISDN Port Control (\$49) command are set to enable the system to send ISDN Port Change of State (\$EA) reports to the host. Under these conditions, the system waits four seconds for the host to respond to the \$EA report with the DISCONNECT message from the network.

**Note**

If the host does not respond to the \$EA report within the 4-second time frame, the system automatically sends the RELEASE message to the network.

If the Enable ISDN Manual Disconnect feature flag is set to Y, do not set the D and R bits (in the \$49 command that established the call) to suppress \$EA reports. If \$EA reports are suppressed, the system cannot send notification or cause IEs for the DISCONNECT to the host. Also, call processing will be delayed by 4 seconds.

When the system receives a DISCONNECT from the network, it reports to the host via an \$EA report that includes all the IEs within the DISCONNECT message. The host sends a \$49 command back to the system, which triggers an outpulse rule that includes a RELEASE message with the appropriate IEs. The system then sends the RELEASE message to the network and sets the B-channel to an idle state. The network finishes the processing by returning a RELEASE COMPLETE message for the outgoing B-channel to the system. The system sends another \$EA report to the host, indicating the outgoing B-channel has been idled and is free for another call.

The host can also initiate a DISCONNECT with the \$49 command. In this case, the DISCONNECT is triggered by the command, which will either execute an outpulse rule or let the system formulate the DISCONNECT message on its own (equivalent to an automatic disconnect).

In response to the \$49 command, the system sends a DISCONNECT message for the incoming B-channel to the network. The network responds to the system with a RELEASE message. The system completes processing by simultaneously returning a RELEASE COMPLETE message and idling the B-channel, and generating an \$EA report to the host which indicates that the incoming B-channel has been idled and is free for another call. The processing flow for this example is shown in Figure 4-21 and Figure 4-22.

Figure 4-21 Processing Flow for Example 9 (Part 1 of 2)

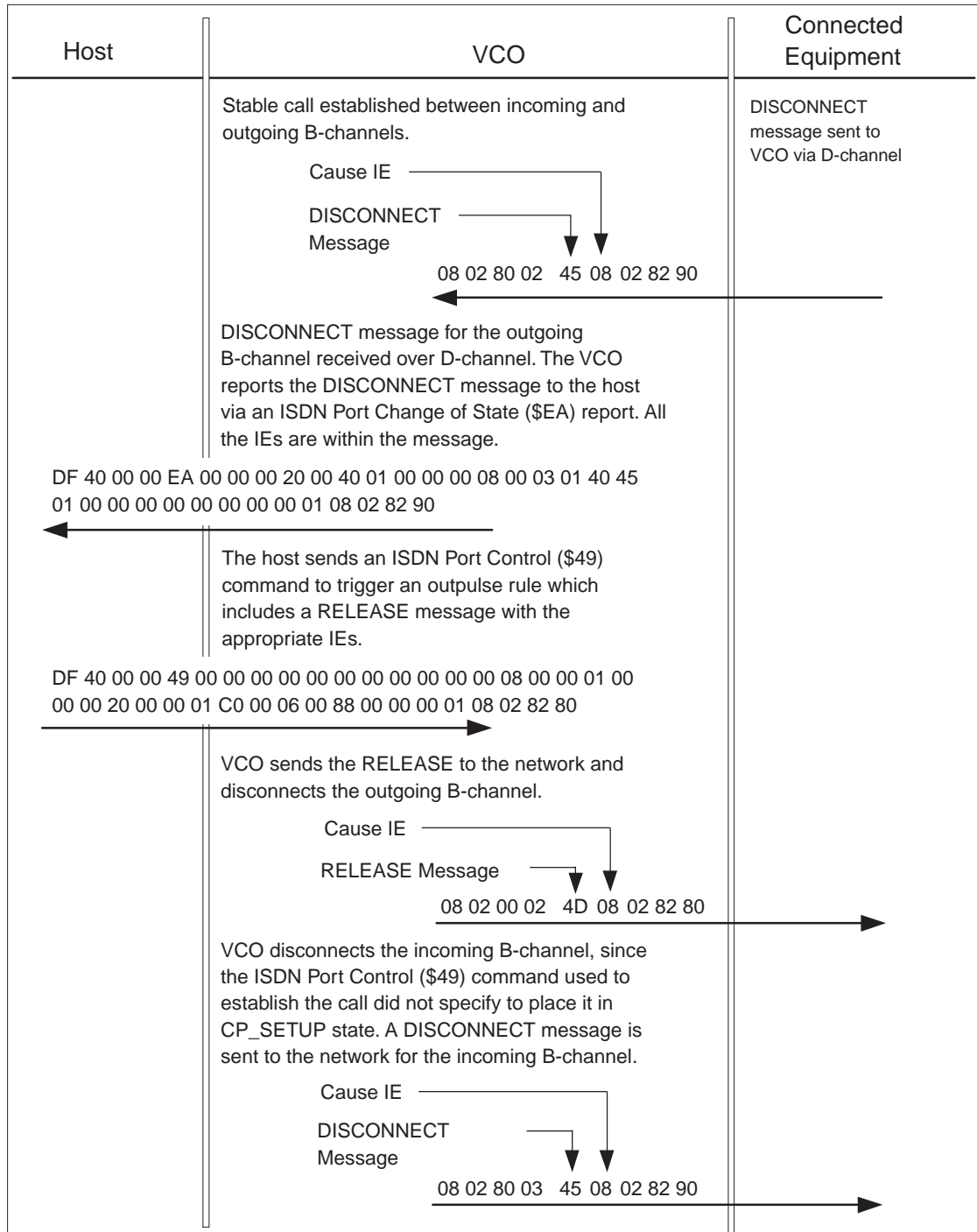

50579

Figure 4-22 Processing Flow for Example 9 (Part 2 of 2)

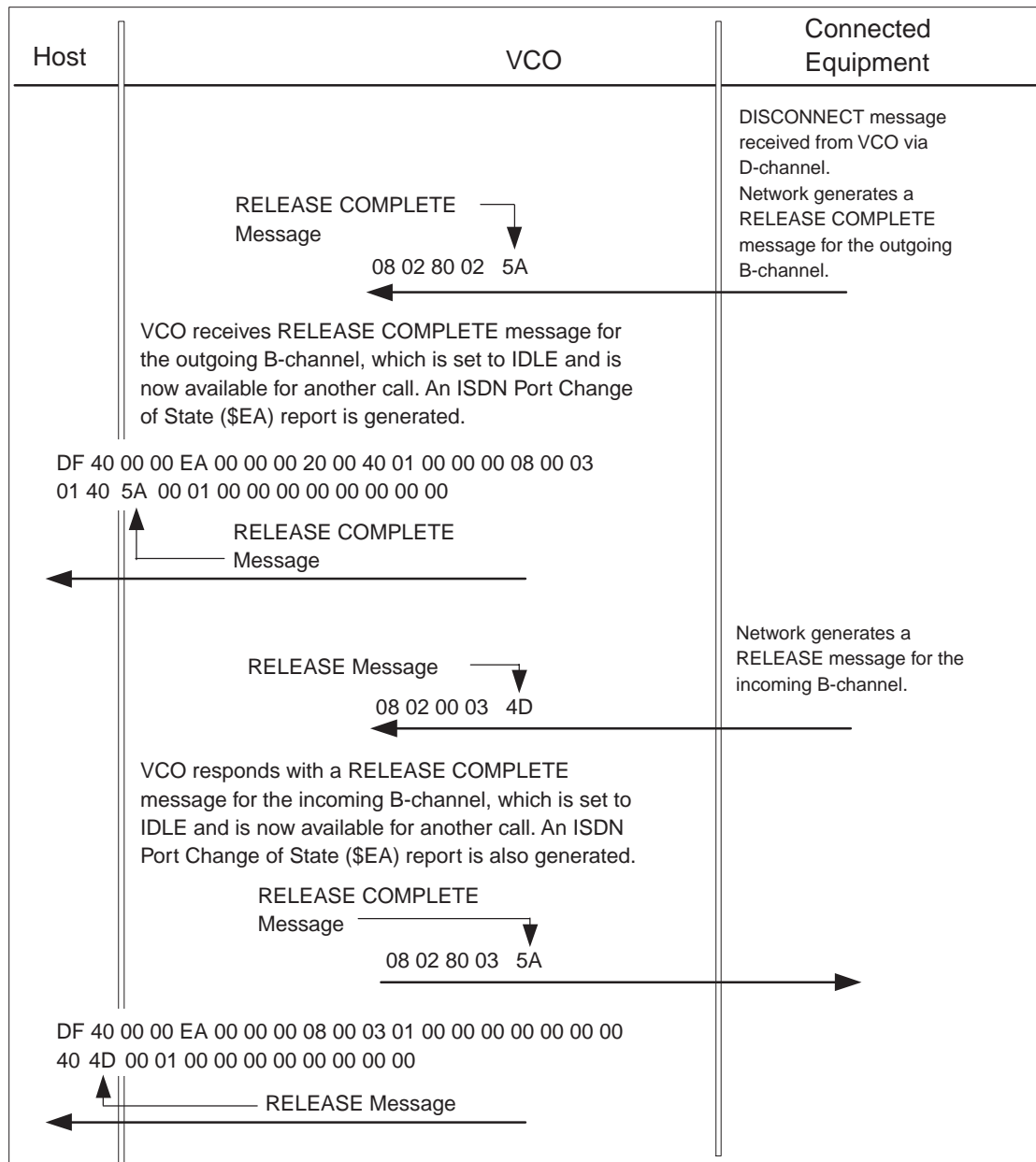

50580



Non-Facility Associated Signaling (NFAS)

This chapter describes the Non-Facility Associated Signaling (NFAS) option available for system ISDN call processing. The following topics are discussed:

- Overview of NFAS capabilities
- NFAS system administration screens—NFAS Group Summary and NFAS Configuration
- Additional general NFAS system administration support
- Implementation strategies and considerations

The functions and screens described in this chapter can only be used when the NFAS option is installed on the system. Installation instructions for the NFAS option are discussed in the “ISDN PRI and ISDN NFAS Installation” section on page 1-3.

NFAS Overview

Standard T1 ISDN PRI consists of 24 channels—where a single signaling channel (D-channel) controls the remaining 23 bearer channels (B-channels) on the interface. In system terms, this means ports 1 through 23 on the ICC ISDN span (B-channels) are controlled by port 24 (D-channel). The NFAS option extends D-channel control to B-channels not resident on the same interface. This allows a single D-channel to control up to 20 interfaces (a maximum of 479 B-channels, or a maximum of 478 with one B-channel as a backup).

The NFAS option does not support all ICC ISDN span types. Table 5-1 lists the ICC ISDN span types and indicates their level of NFAS support.

Table 5-1 NFAS Support for ICC ISDN Span Types

Span Type	NFAS Support?
ICC-T1 PRI/4ESS	Yes
ICC-T1 PRI/5ESS	Yes
ICC-T1 PRI/NI-2	Yes
ICC-T1 PRI/NTI	Yes
ICC-T1 PRI/NTT	No
ICC-E1 PRI/NET5	No
ICC-E1 PRI/TS014	No
ICC-E1 PRI/QSIG	No

The following features are supported for NFAS operation:

- 23B+D ICC ISDN spans—ICC ISDN spans can be defined in the system database as 23B+D spans containing the primary D-channel or backup D-channel (optional) for the NFAS group. The B-channels support 64 KB clear channel interfaces.
- ICC T1 voice channels—ICC T1 channels can be configured as NFAS B-channels within an NFAS group. These ICC T1 channels can interface to 56 KB channels suitable for voice traffic only. ICC T1 spans used as ICC T1/NFAS trunk spans support all configurations available in the ICC ISDN Span Configuration system administration utility.
- Optional D-channel backup—The D-channel on an ICC ISDN span can be designated as a backup to assume control in the event of a primary D-channel failure or network/manual switchover. Switchovers between primary and backup D-channels are performed automatically by the system in response to network events or commands, and can also be initiated manually by the system administrator.

A single system can simultaneously support both standard 23B+D ICC ISDN spans and the NFAS operation.

NFAS Channel Grouping

ICC ISDN spans and ICC T1 spans are assigned to NFAS groups using the system administration functions. Two screens are provided for NFAS configuration—the NFAS Group Summary screen and the NFAS Configuration screen. Each NFAS group consists of an interface containing the primary D-channel and up to 19 additional interfaces (supporting a maximum of 479 B-channels). Up to 37 NFAS groups can be configured, each with a separate primary D-channel. An optional backup D-channel can also be configured for each group (supporting a maximum of 478 B-channels, with one B-channel as a backup).

Instructions for using the NFAS administration screens are provided in the “NFAS System Administration” section on page 5-3.

D-Channel Redundancy

Users have the option of designating a backup D-channel (usually called the D2 channel) for each NFAS group. This allows one D-channel to be active (controlling the NFAS group) while another standby D-channel is available should a D-channel switchover occur. The following conditions can cause a D-channel switchover:

- The primary D-channel data link fails due to circumstances outside the system (the ICC ISDN span line is physically severed, the far-end connected equipment stops transmitting on the D-channel, etc.).
- The ICC ISDN span containing the primary D-channel is deleted from the system database.
- Loss of carrier or out of frame (OOF) event.
- Manual switchover initiated by the system administrator.

If a backup D-channel is defined for the group, all stable calls are maintained when control is passed to the standby D-channel. The standby D-channel transitions from the standby (STBY) state to the in service (IS) state, while the active D-channel transitions from IS to the maintenance busy (MB) state and then to the out of service (OOS) state.

**Note**

To ensure D-channel redundancy, the ISDN interfaces must be provisioned identically at both the system and the network ends. The ICC ISDN span containing the primary D-channel must be connected to the primary (D1) line, while the ICC ISDN span containing the backup D-channel must be connected to the backup (D2) line for the initial contacts and channel switchovers to occur properly.

When a D-channel switchover occurs, a 40-second system timer (T321) is started. If the standby D-channel transitions to IS before the timer expires, all stable calls are maintained and the timer is cancelled. During the switchover, calls that are not stable are cleared by the system. The system then sends an ISDN Port Change of State (\$EA) report to the host for each call cleared. If the timer expires (switchover occurred but was not successful), all calls are cleared. The system generates a System Card Status (\$D9) report for each interface span in the group.

Manual D-channel switchovers are also possible. You can use a command field on the NFAS Configuration screen to force the standby D-channel to assume control of the NFAS group selected. A manual switchover has the same effect on ISDN calls in progress as an automatic switchover.

Refer to Appendix A, “Valid Information Elements for I FLD and D FLD Action Tokens,” for descriptions of D-channel state processing on the primary and backup D-channels during channel initialization and switchovers. The NFAS option follows network requirements for backup D-channel service as discussed in Annex F of the *AT&T Integrated Services Digital Network (ISDN) Primary Rate Interface Specification* (TR 41449) and Appendix F of the *ISDN Primary Rate User-Network Interface Specification* (NIS A211-1). Refer to these publications for more information on switchover timing and D-channel state transitions.

NFAS System Administration

NFAS is defined and configured for your system through the use of two system administration screens—the NFAS Group Summary screen and the NFAS Configuration screen.

NFAS Group Summary Screen

The NFAS Group Summary screen allows you to perform the following functions:

- View a listing of NFAS groups and the number of B-channels in each group.
- Name an NFAS group.
- Access the NFAS Configuration screen.

Up to 37 NFAS groups can be configured for the system from this screen.

To access the NFAS Group Summary screen (see Figure 5-1) from the Database Administration menu, type **L** and press **Enter**. The cursor is located in the first Name field.

Figure 5-1 NFAS Group Summary Screen

N F A S G R O U P S U M M A R Y											
No.	Name	Count	Dsp	No.	Name	Count	Dsp	No.	Name	Count	Dsp
1	_____	-	-	14	_____	-	-	27	_____	-	-
2	_____	-	-	15	_____	-	-	28	_____	-	-
3	_____	-	-	16	_____	-	-	29	_____	-	-
4	_____	-	-	17	_____	-	-	30	_____	-	-
5	_____	-	-	18	_____	-	-	31	_____	-	-
6	_____	-	-	19	_____	-	-	32	_____	-	-
7	_____	-	-	20	_____	-	-	33	_____	-	-
8	_____	-	-	21	_____	-	-	34	_____	-	-
9	_____	-	-	22	_____	-	-	35	_____	-	-
10	_____	-	-	23	_____	-	-	36	_____	-	-
11	_____	-	-	24	_____	-	-	37	_____	-	-
12	_____	-	-	25	_____	-	-				
13	_____	-	-	26	_____	-	-				

50558

The NFAS Group Summary screen consists of one screen. Press **Tab** and **<** to move between Name fields. Press **Next Field** and **Prev Field** to move between the Name and Dsp fields. Press **Print Screen** to obtain a hard copy of any screen.

NFAS Group Summary Screen Field Definitions

The NFAS Group Summary screen has the following fields:

No.—*Display only*. Indicates the number of the NFAS group. Possible values for this field range between 1 and 37.

Name—*Data entry via main keyboard*. Optional entry that determines the name of the NFAS group. This field accepts up to eight alphanumeric characters, either upper- and/or lowercase.

Count—*Display only*. Indicates the number of B-channels currently in this NFAS group. The number is updated when changes are made to the group via the NFAS Configuration screens. The value for this field can be a number between 0 and 479 (or between 0 and 478 with a backup D-channel span).

Dsp—*Data entry via main keyboard, access to another screen(s)*. **Display group**—provides access to the NFAS Configuration screens. Any character on the main keyboard is valid for entry. Refer to the “Changing NFAS Group Summary Screen Field Parameters” section on page 5-4 for instructions on using this field.

Changing NFAS Group Summary Screen Field Parameters

You can change the **Name** field for each group by using the NFAS Group Summary screen. To change this field, complete the following steps:

-
- Step 1** Access the NFAS Group Summary screen. The cursor is located in the Name field of the first group.
 - Step 2** Type the **Name** information, then press **Next Field**. The cursor moves to the Dsp field.

- Step 3** To assign a name to another NFAS group, press **Next Field** and repeat Step 2. Use **Tab** and < to move between Name fields.
- Step 4** When all changes have been made, press **Enter**. The following message is displayed:
- ```
Press ENTER To Update Group Names
```
- Step 5** Press **Enter**. The following message is displayed, and the database is automatically updated.
- ```
NFAS Group Name(s) Updated
```
- Step 6** To display or edit an NFAS group configuration, use the **Next Field** and **Prev Field** keys to position the cursor in the Dsp field corresponding to that group, type any character and press **Enter** (the NFAS Configuration screen is described in the “NFAS Configuration Screen” section on page 5-5). If no further NFAS group changes are to be made, press **Exit** or **Prev Menu** to return to the Database Administration menu.
- To leave the NFAS Group Summary screen without making any changes, press **Exit**, **Prev Menu**, or **Main Menu**. No changes are made to the database unless you press **Enter**.
-

Accessing Other Menus and Screens from the NFAS Group Summary Screen

You can access the following screens from the NFAS Group Summary Screen:

- Main menu—Press the **Main Menu** key.
- Database Administration menu—Press the **Prev Menu** key.

To access the NFAS Configuration screen, complete the following steps:

-
- Step 1** Use the **Prev Field**, **Next Field**, **Tab** or < key to position the cursor in the Dsp field corresponding to the NFAS group you want to edit or display.
- Step 2** Type any character and press **Enter**.
-

NFAS Configuration Screen

Use the NFAS Configuration screen to create NFAS groups. An NFAS group consists of one or two ICC ISDN spans—the primary span and the backup span. The D-channel on the active span, primary or backup, receives the call control messages for the entire NFAS group. All other interfaces in the NFAS group are ICC T1 spans. Each group consists of the following components:

- A group name and number.
- The rack, level, slot (RLS) address of the primary D-channel.
- The RLS address of the backup D-channel (optional).
- The RLS address of each primary ICC ISDN span and/or backup ICC ISDN span, and all ICC T1 spans assigned to the group.

NFAS Group Configuration Rules

The following configuration rules apply to NFAS groups:

- In order to be added to an NFAS group, ICC ISDN span(s) and ICC T1 spans must have been added to the database (via the Card Maintenance screen) and configured (via the ICC ISDN Span Configuration screen or the ICC Programmable Trunk Configuration screen).
- ICC ISDN spans and ICC T1 spans must be out of service (OOS) when added to an NFAS group.
- Spans containing the primary and backup (if defined) D-channels must be added to the NFAS group.
- Up to 20 spans can be assigned to an NFAS group, including the spans containing the primary and backup D-channels.
- Each span can reside in only one NFAS group.

The NFAS Configuration screen is shown in Figure 5-2. The cursor is located in the Primary D-channel RLS field.

Figure 5-2 NFAS Configuration Screen

N F A S C O N F I G U R A T I O N

Group __ of __ Group Name: _____

Primary D-channel RLS: _ _ _ _ State: _____

Backup D-channel RLS: _ _ _ _ State: _____ Cmd: _____

Interface	R L S	Status	D	Interface	R L S	Status	D
0	_ _ _	_____	-	10	_ _ _	_____	-
1	_ _ _	_____	-	11	_ _ _	_____	-
2	_ _ _	_____	-	12	_ _ _	_____	-
3	_ _ _	_____	-	13	_ _ _	_____	-
4	_ _ _	_____	-	14	_ _ _	_____	-
5	_ _ _	_____	-	15	_ _ _	_____	-
6	_ _ _	_____	-	16	_ _ _	_____	-
7	_ _ _	_____	-	17	_ _ _	_____	-
8	_ _ _	_____	-	18	_ _ _	_____	-
9	_ _ _	_____	-	19	_ _ _	_____	-

63590

The NFAS Configuration screen consists of a single screen.

Press **Prev Field** and **Next Field** keys to move between fields for an interface, and from the last field for an interface to the first field for the next interface. Press **Tab** and **<** to move between interface R L S fields. Press **Prev Screen** and **Next Screen** to move through the NFAS Group displays. Press **Print Screen** to obtain a hard copy of this screen.

NFAS Configuration Screen Field Definitions

The NFAS Configuration screen contains the following fields:

Group__of__—*Display only*. Indicates the number of the NFAS group currently displayed. Interpret this field as: Group n of 37, where n is a numerical value in the range from 1 to 37.

Group Name—*Display only*. Indicates the name assigned to the currently displayed NFAS group. This field can be changed using the NFAS Group Summary screen, and can contain up to eight alphanumeric characters, upper- and/or lowercase.

Primary D-channel RLS—*Data entry via main keypad*. Indicates the rack, level, slot (RLS) address of the span which contains the D-channel designated as the primary control channel for the currently displayed NFAS group. Refer to the “ISDN Primary Rate Interface Package” section on page 1-1 for span location conventions.

**Note**

An ICC ISDN span RLS address must be entered in this field for the NFAS group to function. This span must be configured as a 23B+D PRI.

State—*Display only*. This field indicates the current state of the primary D-channel. With the exception of the manual out of service (MOOS) state, the state transitions are controlled by link signaling between the system and the network interface and cannot be set via system administration. Possible values for this field are listed in Table 5-2.

Table 5-2 Primary and Backup D-Channel States

Value	D-Channel State
IS	In service
STBY	Standby
MB	Maintenance busy (transitioning to OOS)
WAIT	Wait (transitioning to IS)
MOOS	Manual out of service
OOS	Out of service

Backup D-channel RLS—*Data entry via main keyboard*. Optional entry that indicates the rack, level, slot (RLS) address of the span which contains the D-channel designated as the backup control channel for the currently displayed NFAS group. Refer to the *Cisco VCO/4K System Administrator's Guide* for span location conventions.

State—*Display only*. This State field indicates the current state of the backup D-channel. Possible values for this for this field are listed in Table 5-2.

Cmd—*Data entry via Select key*. Allows the user to change the state of the backup D-channel using one of three commands, listed in Table 5-3. Use this field to perform a manual switchover between the primary and backup D-channels, and to place the primary or backup D-channel into and out of the manual out of service (MOOS) state.

**Note**

The command selections available to the user depend upon the current state of the standby D-channel. For example, if the D-channel is currently in MOOS state, the only selection available is ACTIVATE.

Table 5-3 Cmd Field Commands and Resulting Backup D-channel State Changes

Command	Change in Backup D-Channel State
MOOS	Places the D-channel currently in STBY state into the manual out of service state regardless of its current state. The D-channel remains in MOOS state until you enter an ACTIVATE command.
ACTIVATE	Places the D-channel in out of service (OOS) state. This command allows you to transition D-channels from MOOS to OOS.
SWITCH	Causes a manual D-channel switchover; the standby D-channel becomes in service (IS) and assumes control of the NFAS group. This command is only valid when a backup D-channel is specified for the group. The standby D-channel must be in STBY state for the switchover to take place.

Interface—*Display only*. Specifies the interface number of the ICC ISDN span or the ICC T1 span being added to the NFAS group. Up to 20 interfaces, including those containing the primary and backup D-channels, are listed for each NFAS group. Corresponding R L S, Status, and D fields are listed for each interface. The interface number must correspond to the provisioning of the interfaces at the far-end connection.

R L S—*Data entry via main keyboard*. Indicates the rack, level, slot (RLS) address of the span. Refer to the *Cisco VCO/4K System Administrator's Guide* for the span location conventions.

**Note**

The primary D-channel and optional backup D-channel (if defined) must be entered in the Interface RLS fields for the NFAS group.

Status—*Display only*. Indicates the current status of the ICC ISDN spans and ICC T1 spans. This field can be changed using the Card Maintenance screens. Possible values for this field are listed in Table 5-4.

Table 5-4 Status Field States and Associated Meanings for ICC ISDN Spans and ICC T1 Spans

State	ICC ISDN Span Status Meaning	ICC T1 Span Status Meaning
ACTIVE	All signal alarms are clear. B-channels (ports) on this span can be involved in active calls and can be allocated to new calls.	
OOS (out of service)	No B-channels (ports) can be involved in active calls; no ports are allocated to new calls.	
MAINT (maintenance)	D-channel may be disabled and an alarm condition may exist. If the span was placed into maintenance using the Card Maintenance screen, the D-channel is still active. One or more B-channels (ports) on this span may be involved in active calls; no ports are allocated to new calls. The span enters this state automatically upon system reset, when the D-channel releases, or for a signal alarm. When the condition clears, the span transitions back to the active state.	The span may have been placed into maintenance using the Card Maintenance screen. One or more B-channels (ports) on this span may be involved in active calls; no ports are allocated to new calls. The span enters this state automatically upon system reset or for a signal alarm. When the condition clears, the span transitions back to active state.

Table 5-4 Status Field States and Associated Meanings for ICC ISDN Spans and ICC T1 Spans (continued)

State	ICC ISDN Span Status Meaning	ICC T1 Span Status Meaning
DIAG (diagnostic)	D-channel is disabled. No B-channels (ports) on this NFAS group are involved in calls or allocated to new calls. Span is in local loopback and sending all 1s (ones).	No B-channels (ports) on this NFAS group are involved in calls or allocated to new calls. Span is in local loopback and sending all 1s (ones).
REMOTE (remote loopback)	D-channel is disabled. No B-channels (ports) on this NFAS group are involved in calls or allocated to new calls. Span is in local and remote loopback.	—

D—Data entry via main keyboard, access to another screen. Depending on the span type, provides access to the appropriate ICC ISDN Span Configuration screen or the ICC Programmable Trunk Configuration screen. Any character is valid for entry.

Specifying RLS Addresses

To specify the RLS address of an interface in an NFAS group, complete the following steps:

-
- Step 1** Position the cursor in the R field. Type the single-digit rack/cabinet number (either 1 or 2) and press **Next Field**. The cursor moves to the L field.
 - Step 2** Type the single-digit level number (0, 1, or 2) and press **Next Field**. The cursor moves to the S field.
 - Step 3** Type the one- or two-digit slot number (2 through 21).
-

Refer to the *Cisco VCO/4K System Administrator's Guide* for span location conventions.

Adding Interfaces to an NFAS Group

Create an NFAS group by adding interfaces to it and specifying a primary (required) and backup (optional) D-channel. All spans that are to be added to the group must be taken out of service prior to their addition to the group. For other NFAS grouping conventions, refer to the preceding sections.

To add an interface or span(s) to an NFAS group, complete the following steps:

-
- Step 1** Display the NFAS Configuration screen for the group to which you want to add interface(s) (refer to the “NFAS Configuration Screen” section on page 5-5). The cursor is located in the Primary D-channel RLS field.
 - Step 2** Change or define the primary D-channel interface as follows:
 - If a primary D-channel interface has already been defined and does not need to be changed, press **Tab**. The cursor moves to the Backup D-channel RLS field.
 - To define or change the primary D-channel interface, type the RLS address of the span that contains the primary D-channel and press **Next Field**. The cursor moves to the Backup D-channel RLS field.
 - Step 3** Change or define the backup D-channel as follows:

- If no backup D-channel is being defined, press **Tab**. The cursor moves to the R field for the first interface.
- To define or change the backup D-channel interface, type the RLS address of the span that contains the backup D-channel and press **Next Field**. The cursor moves to the R L S field for the first interface in the group.

- Step 4** Use the **Tab** key to position the cursor in the R L S field for the interface to be added or changed.
- Step 5** Type the RLS address of the interface. Refer to the “Specifying RLS Addresses” section on page 5-9.
- Step 6** Repeat Step 4 and Step 5 for each interface you want to add or change.
- Step 7** Press **Enter**. The database is automatically updated and the cursor moves to the Group field.
- Step 8** Repeat Step 2 through Step 7 for all NFAS groups you want to change.

**Note**

Before leaving the NFAS Group Configuration screen, verify that a primary D-channel span is defined in the Primary D-channel RLS and Interface R L S fields. If a backup D-channel is defined, verify that its RLS address is also entered in both the Backup D-channel RLS and Interface R L S fields.

- Step 9** Press **Exit** to return to the NFAS Group Summary screen.
- To leave the NFAS Configuration screen without making any changes, press **Exit**, **Prev Menu**, or **Main Menu**. No changes are made to the database unless you press **Enter**.
-

Deleting Interfaces from an NFAS Group

To delete one or more interfaces from an NFAS group, follow these steps:

-
- Step 1** Display the NFAS Configuration screen for the group from which you want to delete interfaces (refer to the “NFAS Configuration Screen” section on page 5-5. The cursor is located in the Primary D-channel RLS field.
- Step 2** Use the **Tab** key to position the cursor in the R L S field for the interface to be deleted.
- Step 3** Using the space bar, space over the address of the interface, leaving the fields blank.
- Step 4** Repeat Step 2 and Step 3 for each interface you want to delete.
- Step 5** Press **Enter**. The database is automatically updated and the cursor moves to the Group field.
- Step 6** Repeat Step 2 through Step 5 for all NFAS groups you want to change.
- Step 7** Press **Exit** to return to the NFAS Group Summary screen.
-

Changing D-Channel States

Change the state of the standby D-channel or cause a manual switchover between the D-channels, by completing the following steps:

-
- Step 1** Display the NFAS Configuration screen for the group from which you want to modify the standby D-channel state (refer to the “NFAS Configuration Screen” section on page 5-5). The cursor is located in the Primary D-channel RLS field.
- Step 2** Press the **Tab** key twice to position the cursor in the Cmd field.
- Step 3** Use the **Select** and **Reverse Select** keys to step through the values until the correct command (MOOS, ACTIVATE or SWITCH) is shown.
- Step 4** Press **Enter**. The following message appears:
`Press ENTER To Submit Command`
- Step 5** Press **Enter** again to submit the command. The display is updated to show the changes to the D-channel state(s), and the following message appears:
`NFAS Configuration Updated`
- Step 6** Repeat Step 2 through Step 5 for all NFAS groups you want to change.
- Step 7** Press **Exit** to return to the NFAS Group Summary screen.
-

Accessing Other Menus and Screens from the NFAS Configuration Screen

You can access the following screens from the NFAS Configuration screen:

- Main menu—Press the **Main Menu** key.
- Database Administration menu—Press the **Prev Menu** key.

To access either the ICC ISDN Span Configuration screen, or the Trunk Card Configuration screen, for a particular interface, complete the following steps:

-
- Step 1** Use the **Prev Field**, **Next Field**, **Tab**, or < key to position the cursor in the Dsp field which corresponds to the interface you want to edit or display.
- Step 2** Type any character and press **Enter**.
-

Additional NFAS System Administration Support

In addition to the NFAS Group Summary screen and NFAS Group Configuration screen, other system administration screens support NFAS. These screens, and their features, are listed below.

NFAS system administration is also supported by system status messages, which are described in the *Cisco VCO/4K System Messages*.

Card Summary Screen

The Card Summary screen identifies ICC ISDN span and ICC T1 spans assigned to NFAS groups in the following ways:

- ICC T1 spans appear as ICC T1/NFAS Trunk type spans.
- ICC ISDN spans containing the primary D-channel appear as ICC T1-PRI/Primary.
- ICC ISDN spans containing the backup D-channel appear as ICC T1-PRI/Backup.

Refer to the *Cisco VCO/4K System Administrator's Guide* for further information on the Card Summary screen.

Card Maintenance Screen

The Card Maintenance screen identifies ICC ISDN span and ICC T1 spans assigned to NFAS groups in the following ways:

- ICC T1 spans appear as ICC T1/NFAS Trunk type spans.
- ICC ISDN spans containing the primary D-channel appear as ICC T1-PRI/Primary.
- ICC ISDN spans containing the backup D-channel appear as ICC T1-PRI/Backup.



Note

If the ICC ISDN span containing the primary D-channel for an NFAS group is deleted using the Card Maintenance screen and no backup D-channel is defined, the configuration for that NFAS group is deleted from the database. The interface spans associated with that group remain listed in the database span table; however, the NFAS group configuration is lost (group name and interface listing is deleted). If a backup D-channel is defined for the group and the ICC ISDN span containing the primary D-channel is deleted, only the primary D-channel setting is removed from the group configuration; all other settings (interfaces and backup D-channel) remain.

Refer to Chapter 2, “System Administration Support,” of this manual and the *Cisco VCO/4K System Administrator's Guide* for more information on ISDN NFAS system administration support.

ICC ISDN Span Configuration Screen

The Type field on the ICC ISDN Span Configuration screen displays ICC ISDN spans containing the primary D-channel as ICC T1-PRI/Primary, while the span containing the backup D-channel is designated as ICC T1-PRI/Backup.

The ICC ISDN Span Configuration screen can be accessed from both the Card Summary screen and the NFAS Group Configuration screen.

Refer to Chapter 2, “System Administration Support,” for further information on the ICC ISDN Span Configuration screen.

ICC Programmable Trunk Configuration Screen

The ICC Programmable Trunk Configuration screen (see Figure 5-3) allows you to configure ICC T1 spans to NFAS groups as ICC T1/NFAS Trunk type spans.

Figure 5-3 ICC Programmable Trunk Configuration Screen

ICC PROGRAMMABLE TRUNK CONFIGURATION							
SPAN LOCATION:	R,L,S 1 1 15-4-1	STATUS:	Out of Service				
CARD TYPE:	ICC T1/NFAS Trunk	SPAN TYPE:	SF	CODE:	AMI		
TXGAIN:	Obd	TXCLCK:	SCLK	SLIP:	255	ALM:	A03 LENG: 0-133
RXGAIN:	Obd	RFCLCK:	LOOP	OOF:	17		
PORT	TRUNK NAME	GROUP	GROUP NAME	SIG. TYPE	INPULSE RULE	COS	LAW
1	-----	---	-----	Clear	0	2	Mu
2	-----	---	-----	Clear	0	2	Mu
3	-----	---	-----	Clear	0	2	Mu
4	-----	---	-----	Clear	0	2	Mu
5	-----	---	-----	Clear	0	2	Mu
6	-----	---	-----	Clear	0	2	Mu
7	-----	---	-----	Clear	0	2	Mu
8	-----	---	-----	Clear	0	2	Mu

50560

ICC Programmable Trunk Configuration Screen Field Definitions—NFAS Specific

Two fields in the ICC Programmable Trunk Configuration screen are specific to NFAS groups—ALM and SIG. TYPE. These two fields are displayed in the ICC Programmable Trunk Configuration screen only when NFAS groups have been defined. The fields are described in detail below.

ALM—*Data entry via Select or Rev Select keys.* The ALM field refers to the alarm specification file which determines how the VCO system responds to ICC alarms. The default value is **SYS**, with an additional selectable value of **A03**, the recommended value for NFAS groups. You must configure the ALM field, which invokes the alarm specification file, to **A03** for NFAS groups.

SIG. TYPE—*Data entry via Select or Rev Select, and Enter keys.* The SIG. TYPE field determines the signal type in use for the ICC span. Possible values, and their meanings, are as follows:

- **E&M**—Default value.
- **E&M01**—Select for ICC-T1/E&M detection of wink_A/B = 1/0 support.
- **E&M02**—Select for inverted E&M (China pulse on idle) support.
- **Clear**—Select for NFAS groups.

After you have selected and entered the first port's signal type, **Clear**, the system software displays the following message at the bottom of your screen:

Enter Y to Propagate port 1 values

Press any key to propagate the **Clear** value to all remaining ports.

Refer to the *Cisco VCO/4K System Administrator's Guide* for further information on the ICC Programmable Trunk Configuration screen.

NFAS Implementation Strategies and Considerations

The following guidelines assist application designers develop ISDN NFAS applications that make the most efficient use of the system. These are guidelines only, and should not preclude other application design approaches. The guidelines are described in the following sections.

General Sequence for Defining NFAS Resources in the System Database

Once NFAS resources (ICC ISDN span and ICC T1 span) are physically inserted in the system equipment frame, use the following steps to add these resources into the system database:

-
- Step 1** Add the ICC ISDN span and ICC T1 spans into the database via the Card Maintenance utility; the spans must be left in the out of service (OOS) mode.
 - Step 2** Access the ICC ISDN Span Configuration screen through the Card Summary screen and define the operating parameters for the ICC ISDN span. Refer to the “Card Summary Screen” section on page 5-12.
 - Step 3** Access the ICC Programmable Trunk Configuration screen through the Card Summary screen and define the operating parameters for the ICC T1 spans. The COS must be defined for each T1 port, but the default inpulse rule is not required. Refer to the “ICC Programmable Trunk Configuration Screen” section on page 5-13.
 - Step 4** Create an NFAS group using the NFAS Group Summary screen.
 - Step 5** Access the NFAS Group Configuration screen through the NFAS Group Summary screen and add all ICC ISDN span and ICC T1 spans to the interface listing.
-

Provisioning Primary and Backup D-Channels

To ensure D-channel redundancy, the PRI interfaces must be provisioned identically at both the system and network end. The ICC ISDN span containing the primary D-channel must be connected to the primary (D1) line, while the ICC ISDN span containing the backup D-channel must be connected to the backup (D2) line for the initial contacts and channel switchovers to occur properly. The interface numbering scheme on the NFAS Group Configuration screen can be used for this purpose.

Backup D-channel Configuration

Users may configure different default inpulse rules for the backup D-channel than those set for the primary D-channel. To ensure consistent operation following a switchover, the default inpulse rule for the primary and backup D-channels should be the same.

ICC T1 Channel Usage

ICC T1 spans used as NFAS B-channels can interface to 56-KB channels, but actually only support 48-KB transmissions. These channels are suitable for voice traffic only and cannot be used for data. Use ICC ISDN span B-channels for data transmissions.

Host Commands During D-Channel Switchover

During a D-channel switchover, some host commands cannot be processed properly because of the slight delay before the backup D-channel is available. These commands are returned with a network status byte of \$3D to indicate that the D-channel is not available. Disconnect commands from the host, however, are processed and queued, waiting for the switchover to complete. These commands appear to process normally to the host.



Valid Information Elements for I FLD and D FLD Action Tokens

Integrated Services Digital Network (ISDN) information elements (IEs) are made up of the following parts:

- Header (or intermediate) information
- Additional information, or data

ISDN message templates use I FLD and D FLD action tokens to specify which portion of a received IE to store in a digit field. This stored information can later be used to construct an IE for transmission over the D-channel. Refer to Chapter 2, “System Administration Support,” for the rules on IE construction.

Figure A-1 to Figure A-6 shows the structure of each IE that can be used in conjunction with the I FLD and D FLD action tokens. Each figure identifies which portion of the IE would be stored using the two tokens. The IE structures have been taken from the International Telecommunications Union guidelines documented in *ITU-T Q.931*.

Figure A-1 Called Party Number Information Element

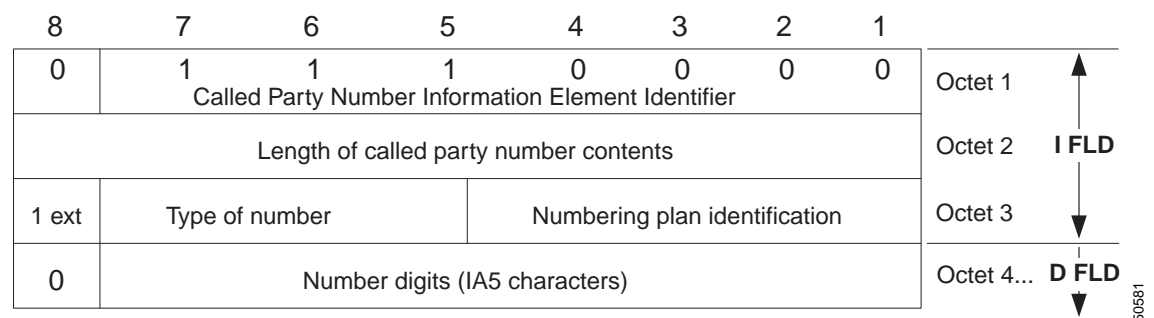

Figure A-2 Called Party Subaddress Information Element

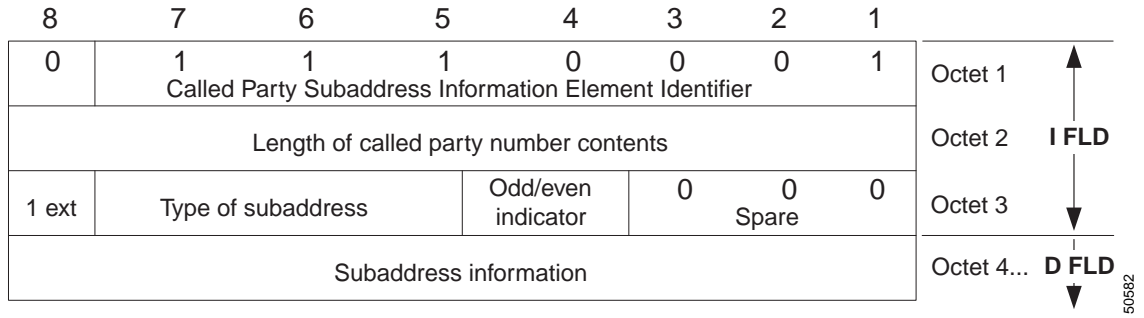
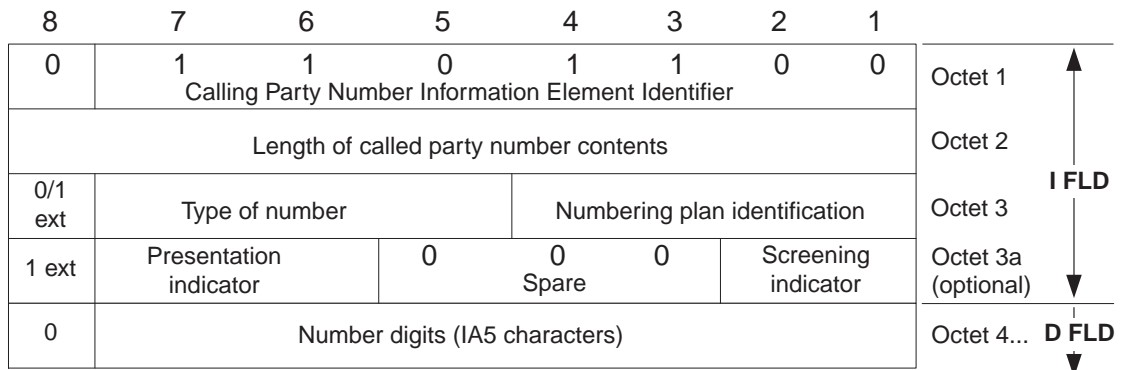

Figure A-3 Calling Party Number Information Element



Note: Octet 3a is optional, per AT&T TR41449.

Figure A-4 Calling Party Subaddress Information Element

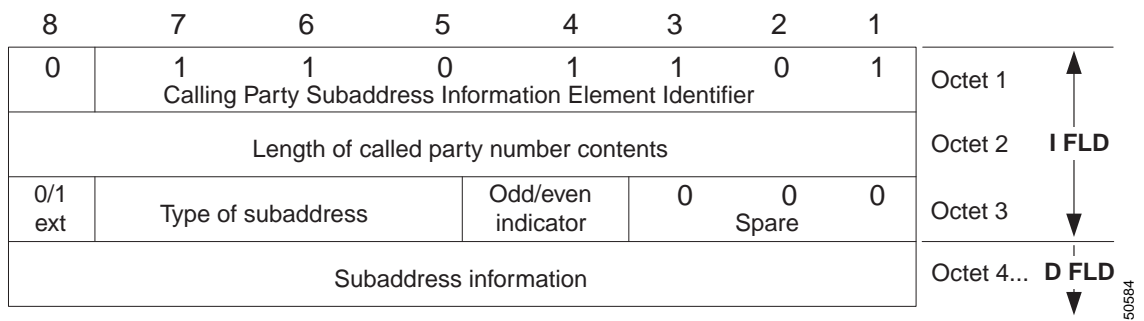

Figure A-5 User-User Information Element

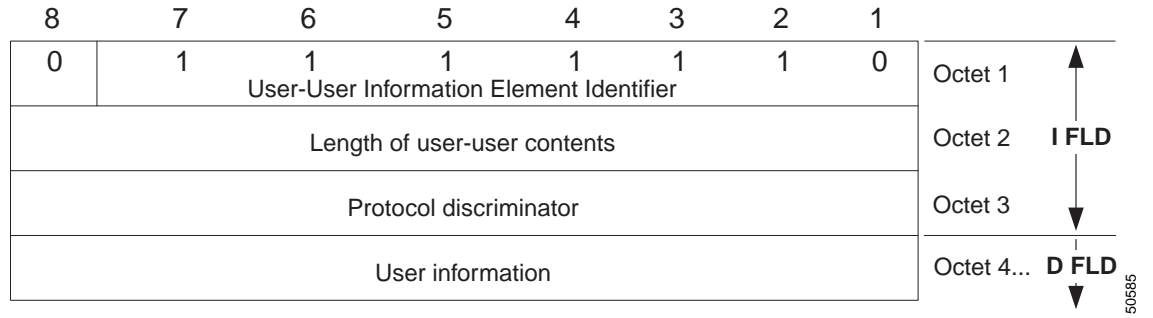
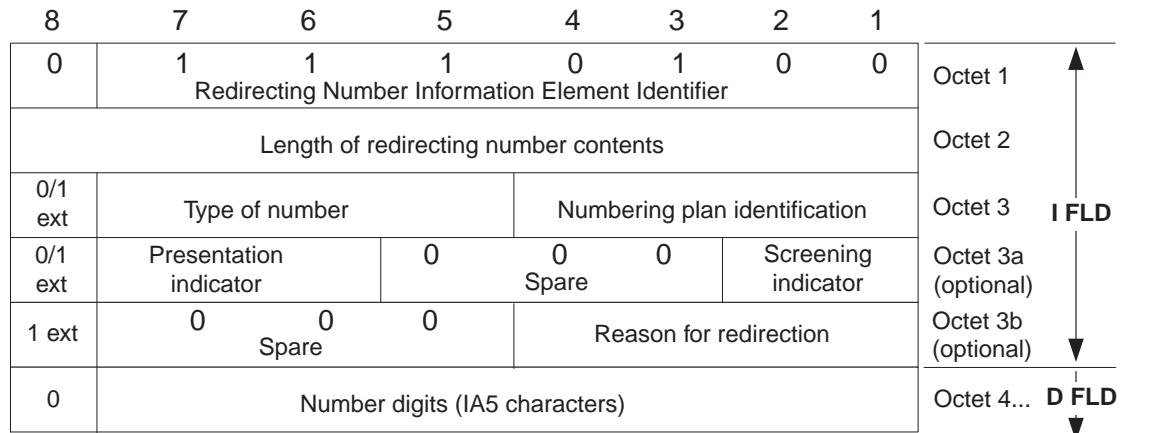

Figure A-6 Redirecting Number Information Element



Note: Octet 3a and octet 3b are optional, per AT&T TR41449.



Cause Information Elements

Cause information elements (IEs) are used in all DISCONNECT and RELEASE D-channel messages generated by ICC PRI ISDN spans to the network. RELEASE COMPLETE messages contain a cause IE only when generated to reject a call because the Host Setup Timer fired. Refer to Chapter 3, “ISDN Processing Overview,” for more information on information element construction and D-channel message processing.

Cause IE values used by the system are listed in Table B-1.

Table B-1 Cause Information Element Values and Meanings

Value	Meaning
\$90	Normal clearing—Indicates normal call clearing procedures.
\$A2	No circuit available—Indicates the system was not able to perform the requested B-channel allocation. Selection is performed based on class of service (COS), not already in use, and in service (IS) status. This value is returned when a preferred channel is requested.
\$A9	Temporary failure—Internal resources necessary to process the call are not available.
\$AA	Network congestion—Indicates that the system is temporarily incapable or allocating the call record memory necessary to process an incoming call attempt. This condition arises when the channel ID IE is not processed by the system and the host has not assigned a B-channel quickly enough to free memory for new incoming calls. This condition can also occur from an unusual influx of new call attempts.
\$AC	Requested channel not available—System cannot allocate the requested B-channel because that channel is already in use, is not the correct class of service (COS), or is not in active service. This value is returned when an exclusive channel is requested.
\$D1	Invalid call reference—D-channel message received with invalid call reference.
\$D2	Channel does not exist—D-channel message received with invalid B-channel specified.
\$E0	Mandatory IE missing—A mandatory IE was not received in a D-channel message.
\$E4	Invalid element contents—An IE was processed with invalid IE coding.



D-Channel Backup Processing

The NFAS option provides D-channel redundancy when both the in service (IS) D-channel fails and a backup D-channel is defined for the NFAS group. This appendix provides graphic representations of the state transitions occurring on the primary D-channel and backup D-channel during channel initialization and switchover. Channel states are displayed on the NFAS Group Configuration screen described in Chapter 5, “Non-Facility Associated Signaling (NFAS).” The figures in this appendix do not provide a complete description of D-channel backup processing. Only the typical states that appear on the NFAS Group Configuration screen are represented.

Figure C-1 represents D-channel initialization as the system attempts to establish a link with the far-end connected equipment. During initialization, the system always attempts to bring the primary D-channel (D1) into the in service (IS) state before attempting to make the backup the controlling D-channel. The solid lines in Figure C-1 indicate this preferred initialization path.

Figure C-2 demonstrates the state transitions during automatic and manual D-channel switchovers.



Note

Figure C-2 assumes that the primary D-channel (D1) is currently in service (IS) while the backup D-channel (D2) is in standby (STBY) state. Switchover processing between the IS channel and the STBY channel is the same regardless of which channel (primary or backup) is currently in IS state.

In both figures, channels that are in IS state (supporting stable calls and allowing new call attempts) are shown in white. Channels that are unable to support new call attempts (in STBY, WAIT, MB, or OOS state) are shaded.

Figure C-1 Redundant D-Channel Initialization

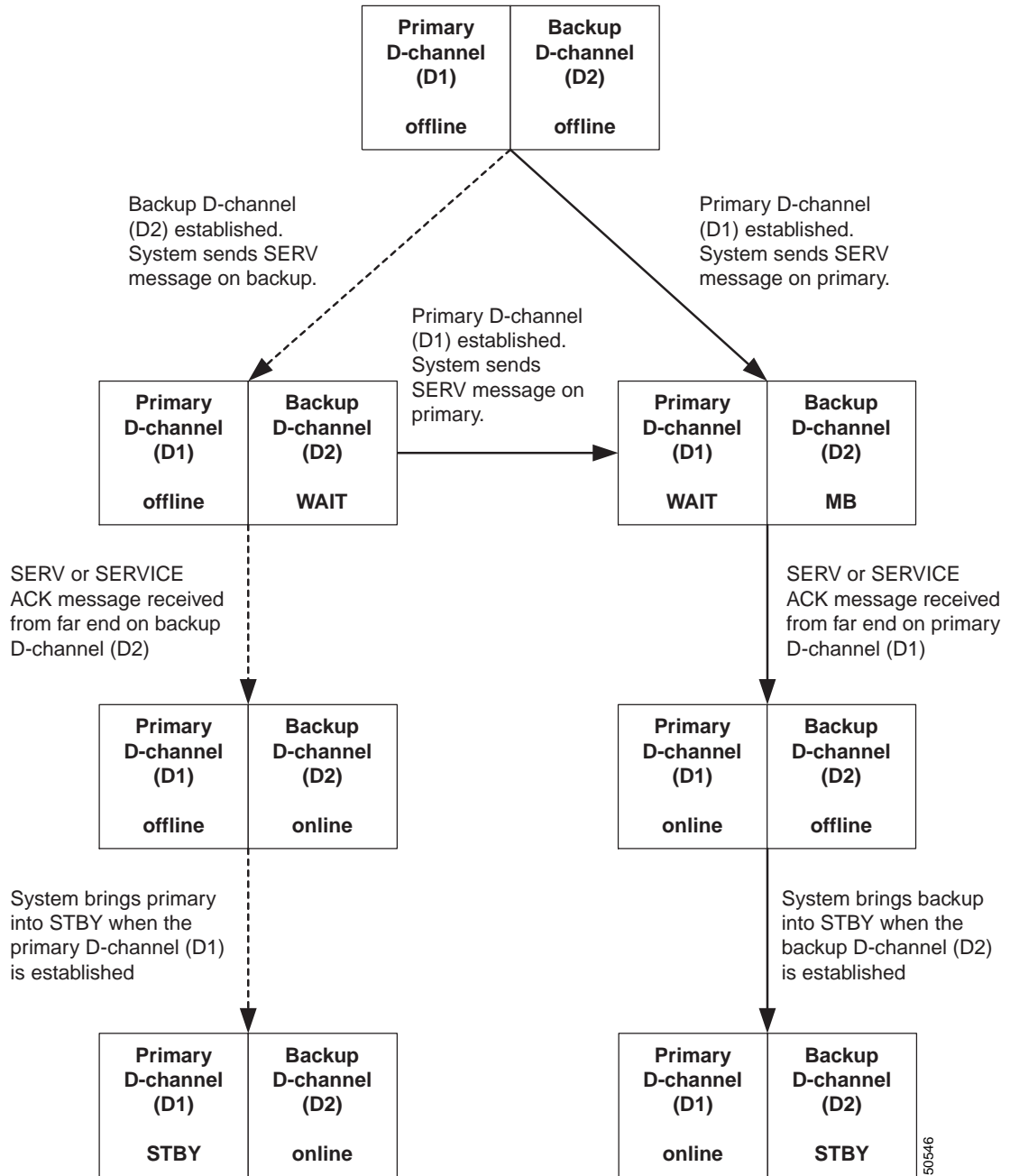

50546

Figure C-2 Channel States During D-Channel Switchover

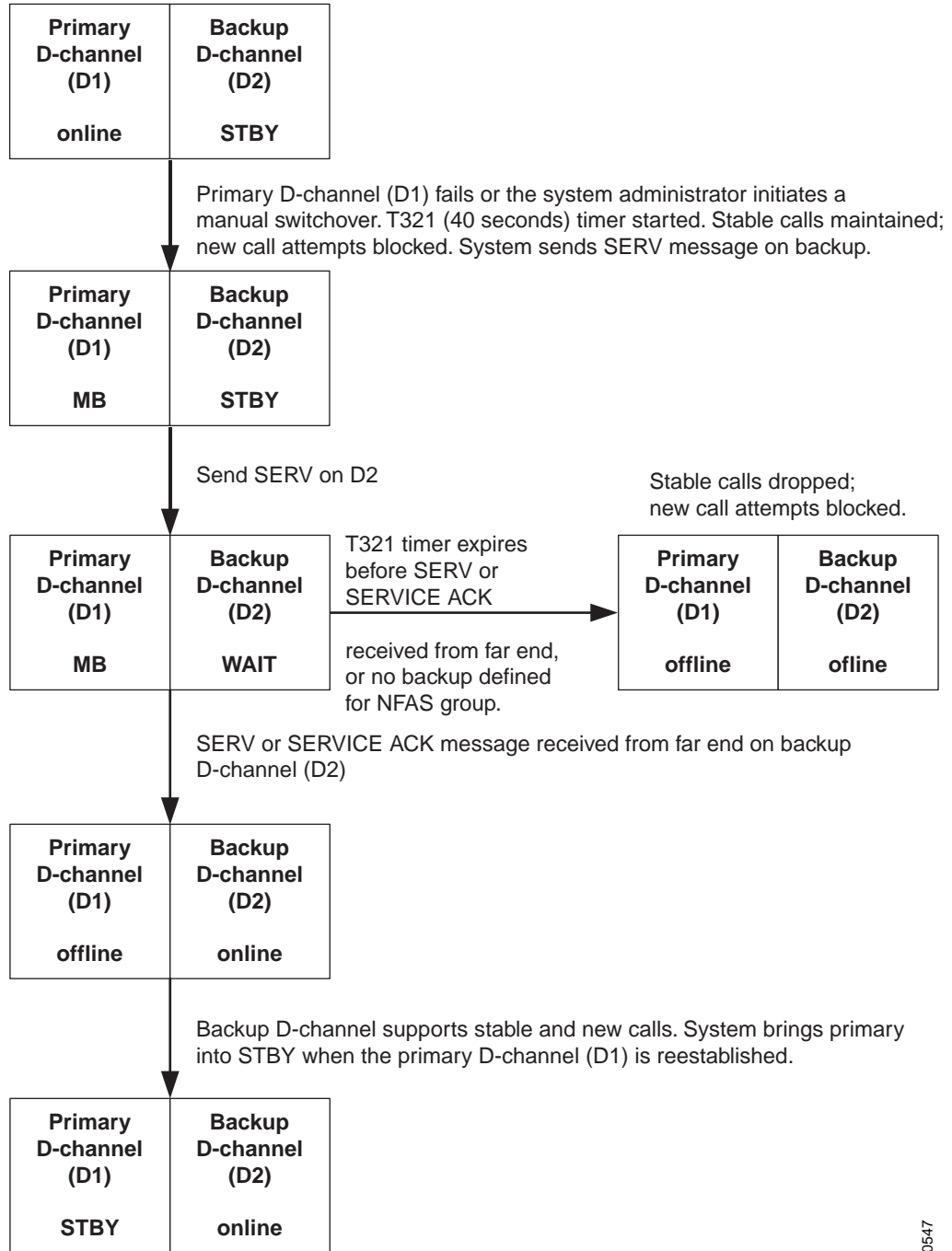

50547

